

SPECIFICATION

FOR APPROVAL

Customer : _____

Product Name : Piezo Buzzer _____

Model Name : VST4314F33 _____

Drawing No. : VS20220806004 _____

Signature of Voice

Approved by	Checkde by	Issued by	Date

 福爱斯电子有限公司
VOISE ELECTRONICS CO.,LTD.

Address:No 96 Mogao Dongqian Lake Industial Area ningbo,China,
Tel:0086-0574-87773030;Fax:0086-0574-87471600 P.C.315121
<http://www.nbvoice.com> Email:sales@nbvoice.com

Specification for Piezo Buzzer		Page	2/5
		Revision No.	1.0
Model No.:	VST4314F33	Drawing No.	VS20220806004

Table of contents

1. Revision
2. Scope
3. General Characteristics
4. Electrical and Acoustic Characteristics.
5. Dimensions
6. Packing

1. Revision

Rev.No.	Date	Page	Description of Revision
1.0	2022/8/6		Preliminary

Specification for Piezo Buzzer		Page	3/5	
		Revision No.	1.0	
Model No.:	VST4314F33		Drawing No.	VS20220806004

2. Scope

This product specification is applied to the Buzzer in alarm systems. Please contact us when using this product for any other applications than described in the above.

3. General Characteristics

- 3.1 Out-Diameter : 42 mm
- 3.2 Height : 14 mm
- 3.3 Weight : 10 g
- 3.4 Operating Temperature : -20~+60°C without loss of function
- 3.5 Store Temperature : -30~+70°C without loss of function

4. Electrical and Acoustic Characteristics.

Test condition : 15 ~ 35 °C Temp., 25% ~ 75% RH, 86~106 kPa Refer to IEC60268-1

No	Items	Specification
1	Rated Voltage	12Vp-p square wave
2	Max Working Voltage	30Vp-p square wave
3	Max. Rated Current	10mA at 3.3KHz/12Vp-p Square Wave
4	Capacitance at 120Hz	30000±30%pF
5	Min Sound Pressure Level	90dB/12Vp-p square wave/30cm
6	Resonant Frequency	3.3±0.5KHz
7	Housing Material	ABS
8	Color	Black

Specification for Piezo Buzzer		Page	4/5
		Revision No.	1.0
Model No.:	VST4314F33	Drawing No.	VS20220806004

5. Dimensions

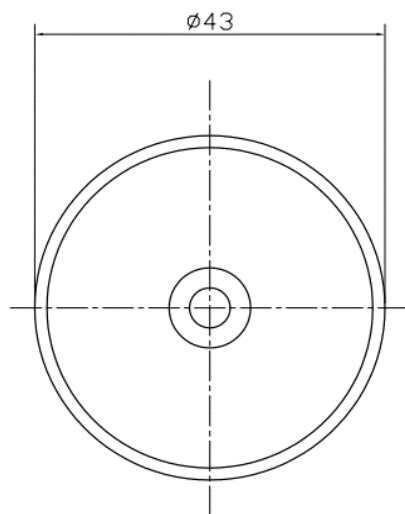
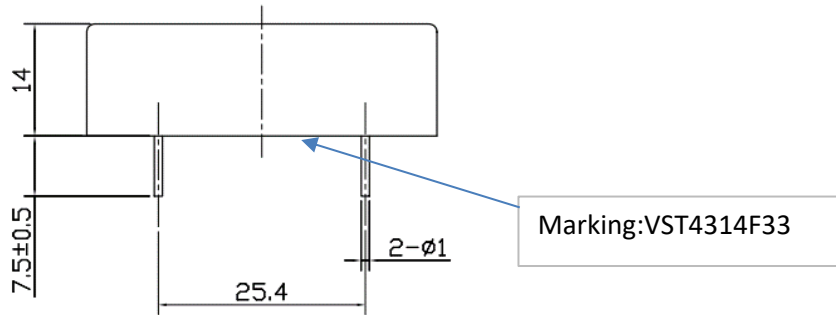

FIRST ANGLE PROJECTION

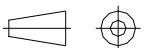

UNIT : mm

Tolerance : ±0.2

Specification for Piezo Buzzer		Page	5/5
		Revision No.	1.0
Model No.:	VST4314F33	Drawing No.	VS20220806004

6. Packing

Each minimum package unit of products shall be in a carton box and it shall be clearly marked with Part Number ,quantity and outgoing inspection number.

There shall be no mechanical damage on products during in storage.