

# Speaker Specification

Customer's Model No.			Customer	ITP/BHARTI	
Kepo Model No.		KPSP50160MF-50/0.25G	Size	Φ 50mm	No. KF3.002.286
No.	Item	Specification	Test Condition		
1	Impedance	50Ω± 15%	at 1.0kHz		
2	Resonant Fr. (f <sub>o</sub> )	500Hz± 20%			
3	Frequency Range	F0-5.5KHz			
4	Rated Power	0.25W			
5	Max Power	0.3W			
6	S.P.L.	90± 3dB	0.1W/0.1M at 1.0k		
7	Distortion	Max 5%	at rated power 1.0kHz		
8	Sweep Test	must be normal	at sine wave 3.53V		
9	Load Test	after test meet item 8	rated noise power, 24 Hrs.		
10	Heat Test	after test meet item 8	50± 2℃ 5Hrs.		
11	Cold Test	after test meet item 8	-20± 2℃ 5Hrs.		
12	Humidity Test	after test meet item 8	40± 2℃,90/95%R.H. 5Hrs.		
13	Weight				
14	Polarity Test	When supplied plus D.C. voltage to (+) terminal, the cone must move to forward.			
15	Note				

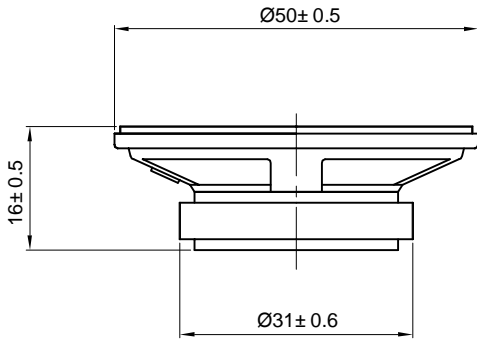

Dimensions:

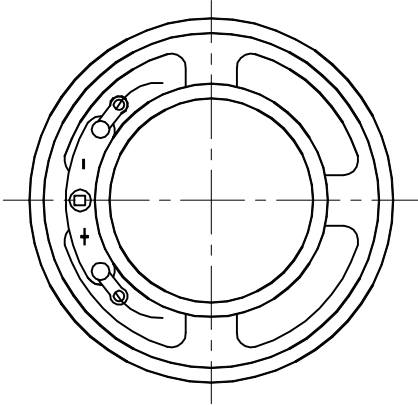

FIRST ANGLE PROJECTION

UNIT : mm  
Tolerance :  $\pm 0.2$