

SHOULDER

SPECIFICATION

Item:	SAW Resonator
Type:	TO39, F11, F12





SAW Resonator

Scope

This specification shall cover the characteristics of 1-port SAW resonator.



T039



F11



F12

The 1-port SAW Resonator is designed to be the frequency control element in transmitters and receiver local oscillators, allowing reduced receiver bandwidths, which results in improved sensitivity and immunity to interference.

The SAW Resonators are typically required in applications such as wireless point of sale terminals, computer peripherals and personal and home security.

Electrical Characteristics		
Parameter		Value
Center Frequency (Fc)		See table 1
Frequency Tolerance (at 25°C)		See table 1
Operating Temperature Range		-20°C to +85°C
Storage Temperature Range		-45°C to +85°C
DC Voltage V_{DC}		10V
AC Voltage V_{PP}		10V 50Hz/60Hz
RF Power Dissipation		0dBm
Insertion Loss		See table 1
Quality Factor Unload Q		12.800 typical
50Ω Load Q		2.000 typical
Temperature Stability	Turnover Temperature (T_o)	50°C Maximum
	Turnover Frequency (f_o)	$f_o \pm 1.3$ typical
	Freq. Temp. Coefficient (FTC)	0.032ppM/°C ²
Frequency Aging (at 25°C)		± 10 ppM/year
DC Insulation Resistance between any two pins		1.0MΩ minimum
RF Equivalent RLC Model	Motional Resistance (R_M)	26Ω Maximum
	Motional Indutance (L_M)	86μH typical
	Motional Capacitance (C_M)	1.5pF typical
Pin 1 to Pin 2 Static Capacitance (C_o)		2.3pF Maximum
Transducer Static Capacitance (C_p)		1.9pF typical

Remark

1. Static Voltage

Static voltage between signal load & ground may cause deterioration & destruction of the component. Please avoid static voltage.

2. Ultrasonic cleaning

Ultrasonic vibration may cause deterioration & destruction of the component. Please avoid ultrasonic cleaning.

3. Soldering

Only leads of component may be soldered. Please avoid soldering another part of component.



SAW Resonator

Mechanical Dimensions (All in mm) TO39

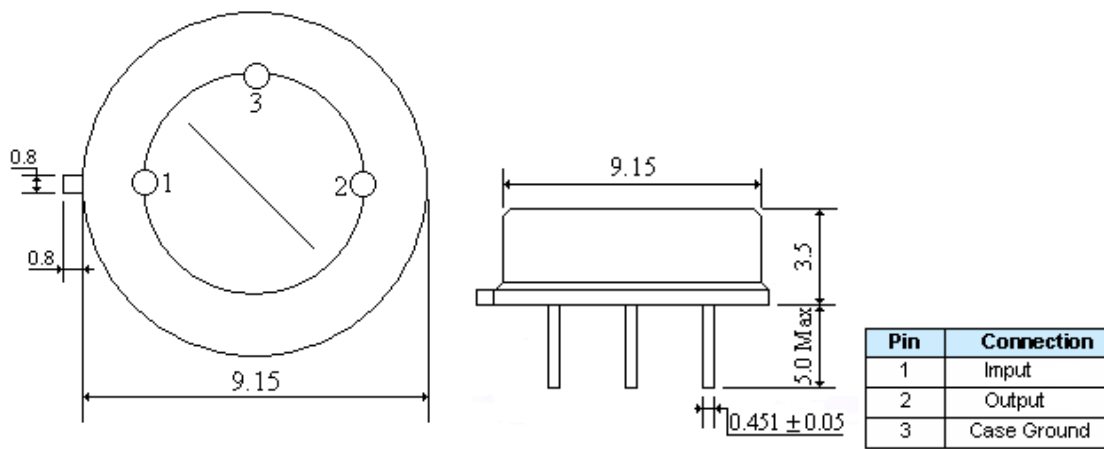

Mechanical Dimensions (All in mm) F11

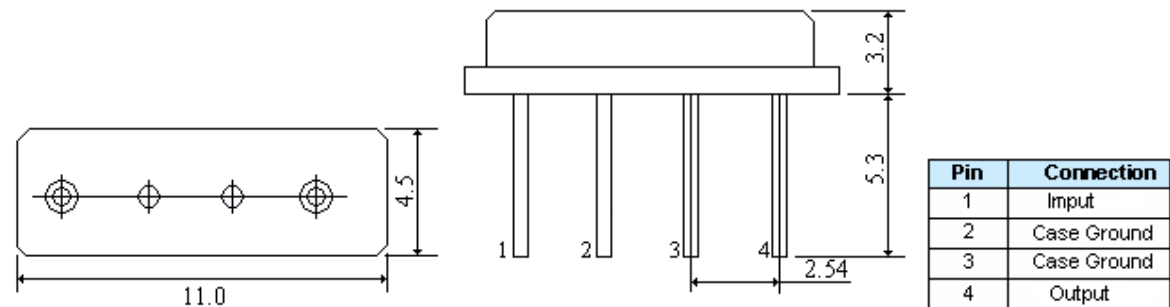

Mechanical Dimensions (All in mm) F12

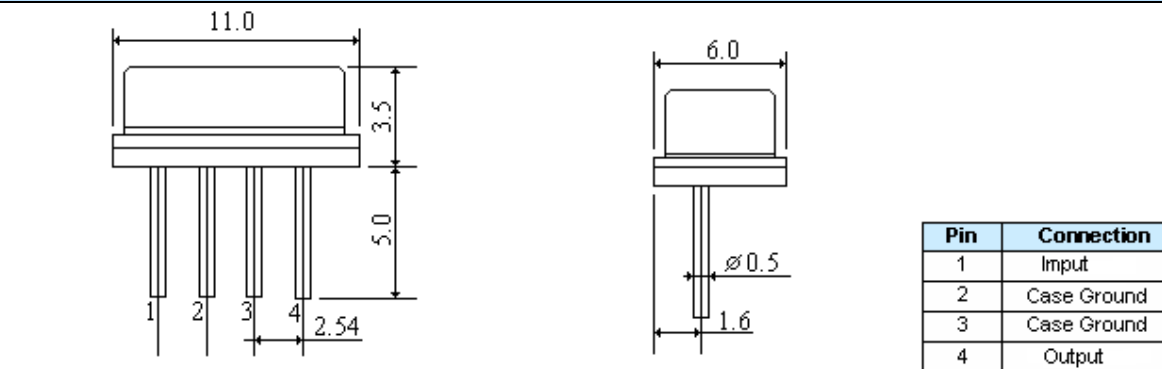



SAW Resonator

Electrical Test TO39

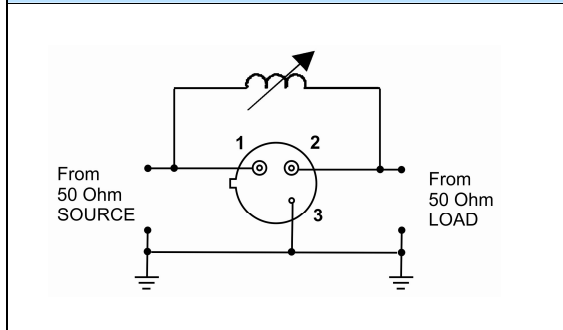

Electrical Test F11, F12

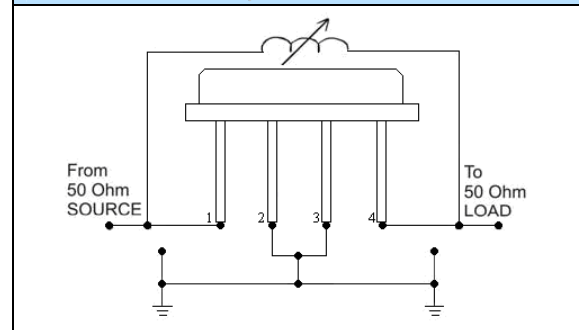

Typical Local Oscillator Application

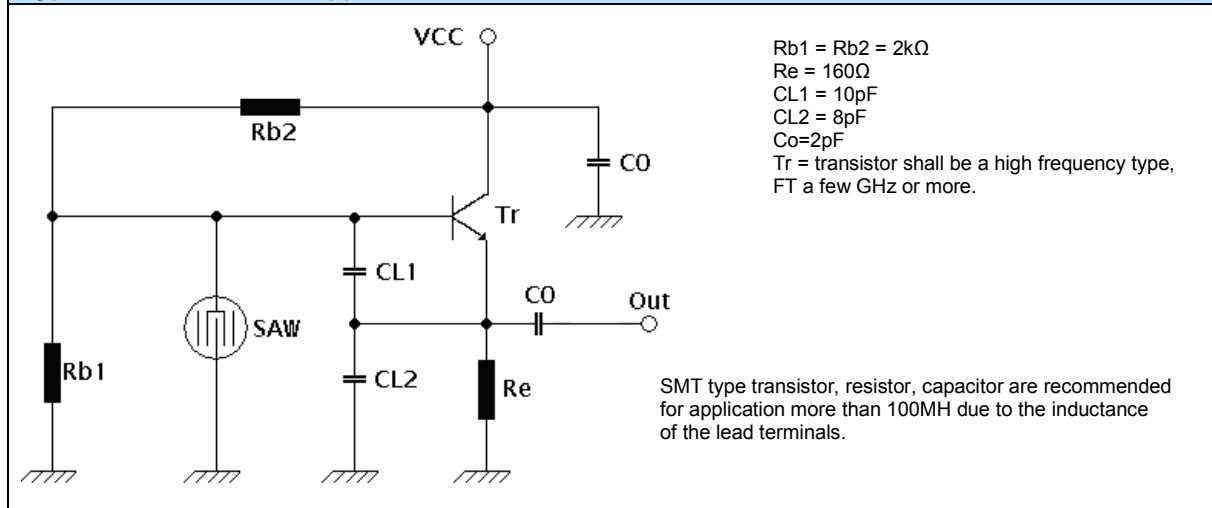

Temperature Characteristics

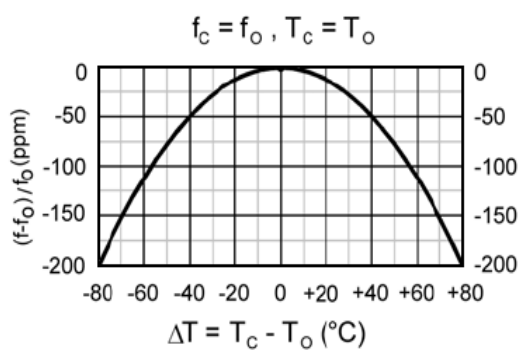

Equivalent LC Model

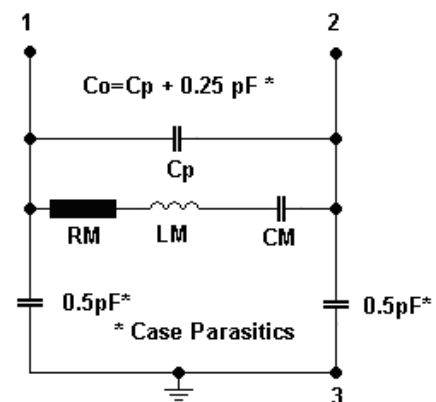



SAW Resonator

Environmental Specification	
1. Moisture	
Keep the device at 40°C and 95% rh for 96 hours. Then release the device into the room conditions for 1 to 2 hours prior to the measurement. It shall meet all the initial electrical characteristics.	
2. Temperature cycling	
Subject the device to a low temperature of 55°C for 30 minutes. Following by a high temperature of +85°C for 30 minutes. Then release the device into the room conditions for 1 to 2 hours prior to the measurement. It shall meet all the initial electrical characteristics.	
3. Resistance to solder heat	
Dip the device terminals no closer than 1.5mm into the solder bath at 260±10°C for 10±1 sec. Then release the device into the room conditions for 1 to 2 hours. It shall meet all the initial electrical characteristics.	
4. Mechanical shock	
Drop the device randomly onto the concrete floor from the height of 20cm 3 times. The device shall meet all the initial electrical characteristics.	
5. Vibration	
Subject the device to the vibration for 1 hour each in x, y and z axes with the amplitude of 1.5 mm at 10 to 55 Hz. The device shall meet all the initial electrical characteristics.	
6. Lead fatigue	
Pulling test	Weight along with the direction of lead without an shock 3 kg. The device shall meet all the initial electrical characteristics.
Bending test	Lead shall be subject to withstand against 90°C bending in the direction of thickness. This operation shall be done toward both directions. The device shall show no evidence of damage and shall meet all the initial electrical characteristics.

Through Hole SAW Resonator Part Numbering System (Example)

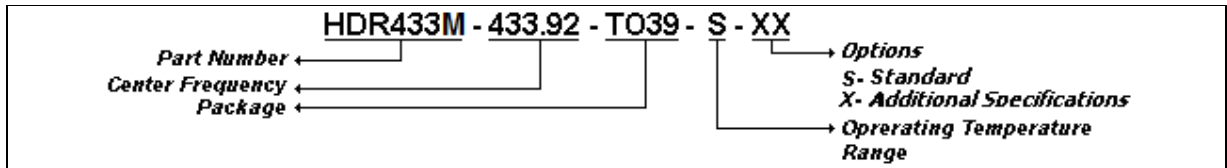

HDR433M	433.92	TO39	S	S
↕	↕	↕	↕	↕
Part Number	Center Frequency in (MHz)	Package	Operating Temperature Range	Option (can be blank)
See Table 1	See Table 1	F11, F12, TO39 See Table 1	S= Standard	S= Standard X= Additional Specifications

- * **Operating Temperature Range: -20 to 80°C (Standard)**
- * **Specific Operating Temperature Range under request.**



SAW Resonator

Table 1:

Part Number	Center Frequency (MHz)	Frequency Tolerance (KHz)	Insertion Loss (dB)	Package
HDR115M	115.0	+ 100	2.5	F12
HDR119M	119.2	+ 100	2.5	F12
HDR224M	224.500	+ 100	2.5	TO39, F11
HDR260M	260.000	+ 100	2.5	TO39, F11
HDR293M	293.975	+ 100	2.5	TO39, F11
HDR297M	297.800	+ 100	2.5	TO39, F11
HDR303K	303.875	+ 100	2.5	TO39, F11
HDR303M	303.825	+ 100	2.5	TO39, F11
HDR304M	304.300	+ 100	2.5	TO39, F11
HDR305M	305.000	+ 75	2.5	TO39, F11
HDR307M	307.500	+ 75	2.5	TO39, F11
HDR308M	308.500	+ 75	2.5	TO39, F11
HDR310M	310.000	+ 75	2.5	TO39, F11
HDR314M	314.500	+ 75	2.5	TO39, F11
HDR315M	315.000	+ 75	2.5	TO39, F11
HDR316.8M	316.800	+ 75	2.5	TO39, F11
HDR318M	318.000	+ 75	2.5	TO39, F11
HDR320M	320.000	+ 75	2.5	TO39, F11
HDR325M	325.000	+ 75	2.5	TO39, F11
HDR330M	330.000	+ 75	2.5	TO39, F11
HDR335.1M	335.100	+ 75	2.5	TO39, F11
HDR340M	340.000	+ 75	2.5	TO39, F11
HDR345M	345.000	+ 75	2.5	TO39, F11
HDR360M	360.000	+ 75	2.5	TO39, F11
HDR372.5M	372.500	+ 75	2.5	TO39, F11
HDR382M	382.840	+ 75	2.5	TO39, F11
HDR383M	383.160	+ 75	2.5	TO39, F11
HDR390M	390.000	+ 75	2.5	TO39, F11
HDR395M	395.000	+ 75	2.5	TO39, F11
HDR403K	403.550	+ 75	2.5	TO39, F11
HDR407M	407.300	+ 75	2.5	TO39, F11
HDR418M	418.000	+ 75	2.5	TO39, F11
HDR422M	422.000	+ 75	2.5	TO39, F11
HDR423M	423.220	+ 75	2.5	TO39, F11
HDR426M	426.062	+ 75	2.5	TO39, F11
HDR433.42M	433.420	+ 75	2.5	TO39, F11
HDR433M	433.920	+ 75	2.5	TO39, F11
HDR435M	435.700	+ 75	2.5	TO39, F11
HDR447M	447.625	+ 100	2.5	TO39, F11
HDR456M	456.800	+ 100	2.5	TO39, F11
HDR457M	457.500	+ 100	2.5	TO39, F11
HDR462M	462.500	+ 150	2.5	TO39, F11
HDR479M	479.500	+ 150	2.5	TO39, F11
HDR857.65M	857.650	+ 250	2.5	TO39, F11
HDR868M	868.000	+ 250	2.5	TO39, F11
HDR868.35M	868.350	+ 250	2.5	TO39, F11
HDR868.95M	868.950	+ 250	2.5	TO39, F11
HDR915M	915.000	+ 250	2.5	TO39, F11