

规格书编号

SPEC NO :

# 产品规格书

# SPECIFICATION

CUSTOMER 客户: \_\_\_\_\_

PRODUCT 产品: \_\_\_\_\_ SAW FILTER \_\_\_\_\_

MODEL NO 型号: \_\_\_\_\_ HDF626A-S4 \_\_\_\_\_

MARKING 印字: \_\_\_\_\_ HDF4607 \_\_\_\_\_

PREPARED 编制: 王岩岩 CHECKED 审核: 邓攀

APPROVED 批准: 王岩岩 DATE 日期: 2010-7-6

客户确认 CUSTOMER RECEIVED:		
审核 CHECKED	批准 APPROVED	日期 DATE

无锡市好达电子有限公司  
Shoulder Electronics Limited



**1. Package Dimension**

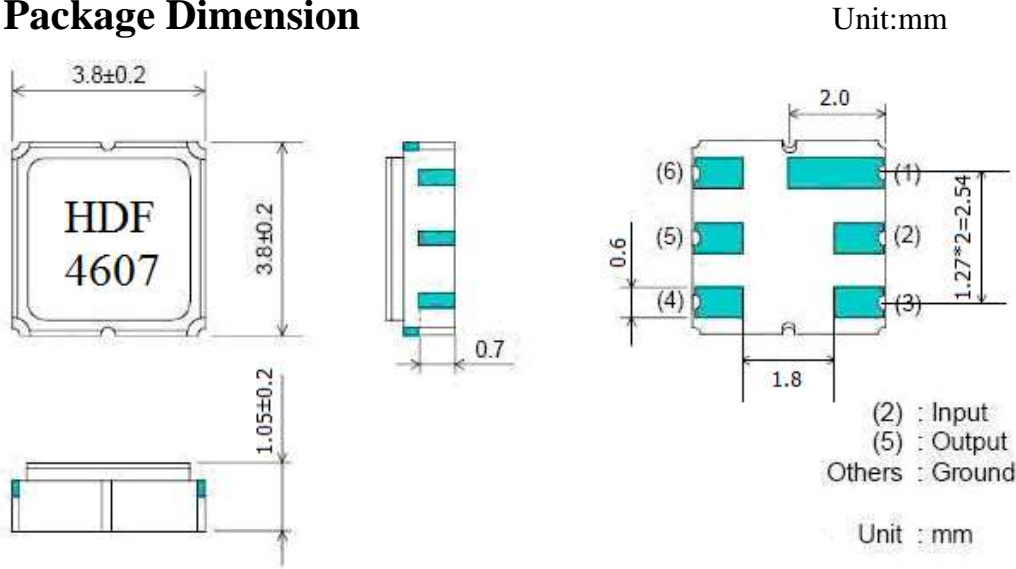

**2. Marking: HDF4607**

- HD: Brand
- F : Filter
- 4 : SMD-4
- 607 : No.

**3.Performance**

3.1 Application

Low-Loss SAW Filter of cordless system.  
Center Frequency:626 MHz

3.2 Maximum Rating

Operation Temperature Range	-40°C to +85°C
Storage Temperature Range	-40°C to +85°C
DC. Permissive Voltage	0 V
Maximum Input Power	11dBm

3.3 Electronic Characteristics

	Unit	Minimum	Typical	Maximum
Center Frequency	MHz	-	626	-
Insertion Loss (In Fc +/- 4 MHz)	dB		2.0	3.5
Amplitude Ripple (In Fc +/- 4 MHz)	dB		1.0	2.0
Relative Attenuation 0.3 MHz ~ Fo-35 MHz	dB	40	50	-
Fo+45 MHz ~ ....		40	50	
Input/Output Impedance	Ohms		50	

### 3.4 Frequency Characteristics

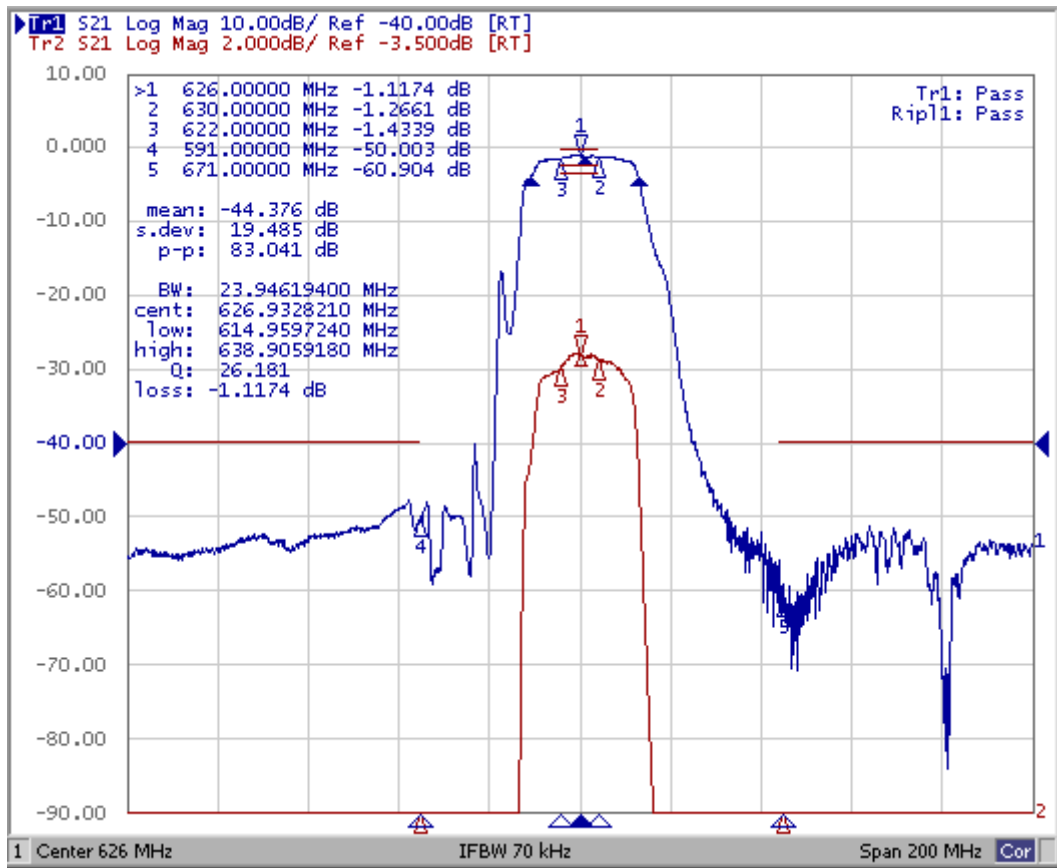

### 3.5 Test Circuit

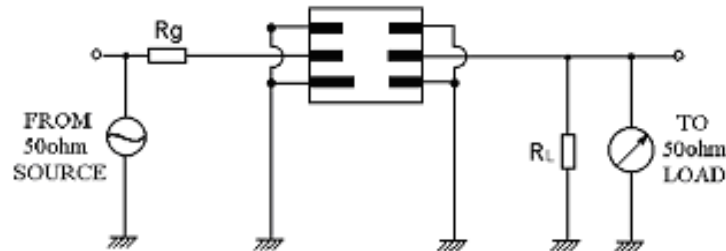

## 4. ENVIRONMENTAL CHARACTERISTICS

### 4-1 Temperature cycling

Subject the device to a low temperature of  $-45^{\circ}\text{C}$  for 30 minutes. Following by a high temperature of  $+25^{\circ}\text{C}$  for 5 Minutes and a higher temperature of  $+85^{\circ}\text{C}$  for 30 Minutes. Then release the device into the room conditions for 1 to 2 hours prior to the measurement. It shall meet the specifications in 3.3.

### 4-2 Resistance to solder heat

Submerge the device terminals into the solder bath at  $260^{\circ}\text{C} \pm 5^{\circ}\text{C}$  for  $10 \pm 1$  sec. Then release the device into the room conditions for 4 hours. It shall meet the specifications in 3.3.

### 4-3 Solderability

Submerge the device terminals into the solder bath at  $245^{\circ}\text{C} \pm 5^{\circ}\text{C}$  for 5s, More than 95% area of the soldering pad must be covered with new solder. It shall meet the specifications in 3.3.

#### 4-4 Mechanical shock

Drop the device randomly onto the concrete floor from the height of 1 m 3 times. the filter shall fulfill the specifications in 3.3.

#### 4-5 Vibration

Subject the device to the vibration for 2 hour each in x,y and z axes with the amplitude of 1.5 mm at 10 to 55 hz. The filter shall fulfill the specifications in 3.3.

## 5. REMARK

### 5.1 Static voltage

Static voltage between signal load & ground may cause deterioration & destruction of the component. Please avoid static voltage.

### 5.2 Ultrasonic cleaning

Ultrasonic vibration may cause deterioration & destruction of the component. Please avoid ultrasonic cleaning

### 5.3 Soldering

Only leads of component may be soldered. Please avoid soldering another part of component.

## 6. Packing

### 6.1 Dimensions

- (1) Carrier Tape: Figure 1
- (2) Reel: Figure 2
- (3) The product shall be packed properly not to be damaged during transportation and storage.

### 6.2 Reeling Quantity

- |               |      |
|---------------|------|
| 1000 pcs/reel | 7''  |
| 3000 pcs/reel | 13'' |

### 6.3 Taping Structure

- (1) The tape shall be wound around the reel in the direction shown below.

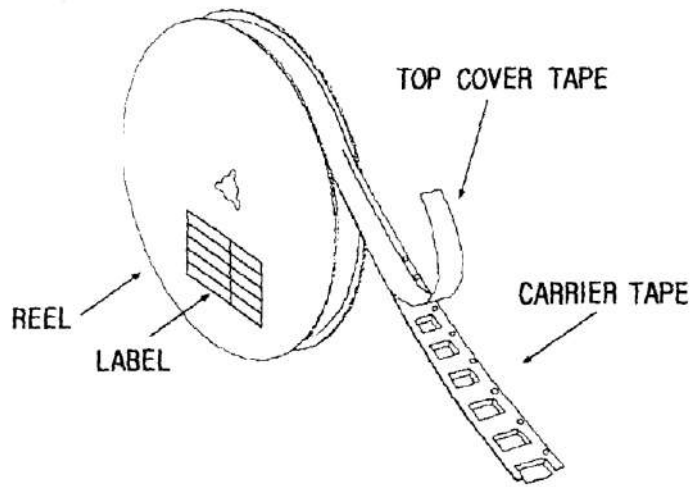

(2) Label

Device Name	
User Product Name	
Quantity	
Lot No.	

(3) Leader part and vacant position specifications.

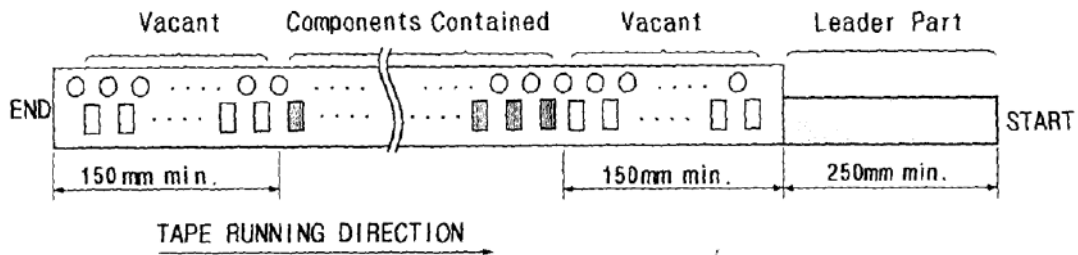

## 7. TAPE SPECIFICATIONS

7.1 Tensile Strength of Carrier Tape: 4.4N/mm width

7.2 Top Cover Tape Adhesion (See the below figure)

- (1) pull off angle: 0~15°
- (2) speed: 300mm/min.

(3) force: 20~70g

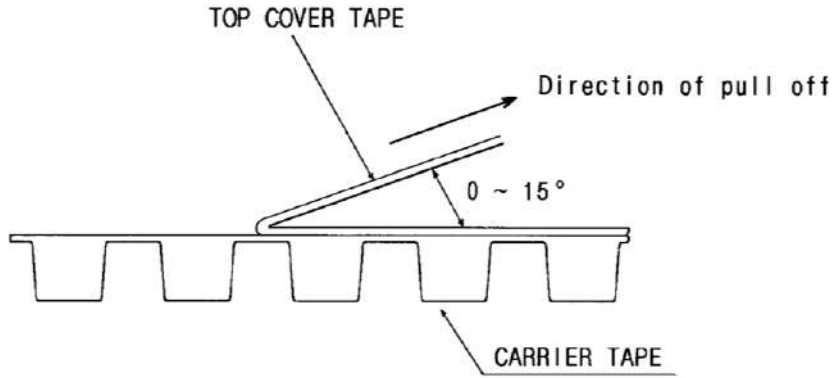

[Figure 1] Carrier Tape Dimensions

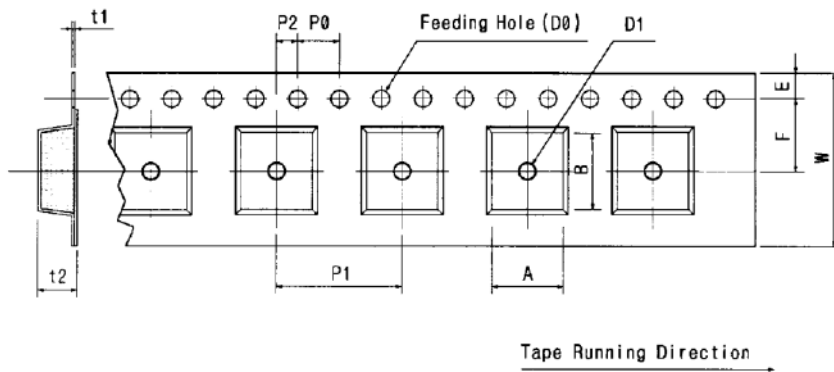

[Unit:mm]

W	F	E	P0	P1	P2	D0	D1	t1	t2	A	B
12.00	5.50	1.75	4.00	8.00	2.00	Ø1.50	Ø1.0	0.25	1.65	4.04	4.10
±0.30	±0.10	±0.10	±0.10	±0.10	±0.10		±0.25	±0.05	±0.10	±0.10	±0.10

[Figure 2]

[Unit:mm]

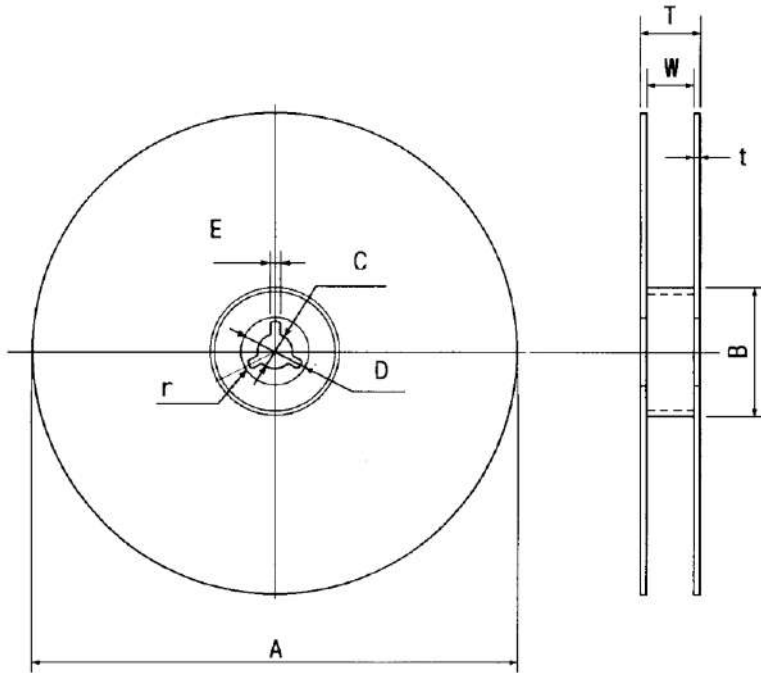

A	B	C	D	E	W	t	r
Ø330	Ø100	Ø13	Ø21	2	13	3	1.0
±1.0	±0.5	±0.5	±0.8	±0.5	±0.3	max.	max.