

规格书编号

SPEC NO :

# 产品规格书

# SPECIFICATION

CUSTOMER 客户: \_\_\_\_\_

PRODUCT 产品: \_\_\_\_\_ SAW FILTER \_\_\_\_\_

MODEL NO 型号: \_\_\_\_\_ HDF465A1-S6 \_\_\_\_\_

MARKING 印字: \_\_\_\_\_ HDF6498 \_\_\_\_\_

PREPARED 编制: \_\_\_\_\_ CHECKED 审核: \_\_\_\_\_

APPROVED 批准: \_\_\_\_\_ D A T E 日期: \_\_\_\_\_ 2011-12-23 \_\_\_\_\_

客户确认 CUSTOMER RECEIVED:		
审核 CHECKED	批准 APPROVED	日期 DATE

无锡市好达电子股份有限公司  
Shoulder Electronics Limited

**更改历史记录**  
**History Record**

更改日期 Date	规格书编号 Spec. No.	产品型号 Part No.	客户产品型号 Customer No.	更改内容描述 Modify Content	备注 Remark

### 1. SCOPE

This specification shall cover the characteristics of SAW filter With F465A1 used for the page system.

### 2. ELECTRICAL SPECIFICATION

DC Voltage VDC	10V
AC Voltage Vpp	10V50Hz/60Hz
Operation temperature	-40°C to +85°C
Storage temperature	-45°C to +85°C
RF Power Dissipation	27dBm

#### Electronic Characteristics

##### 2-1. Typical frequency response

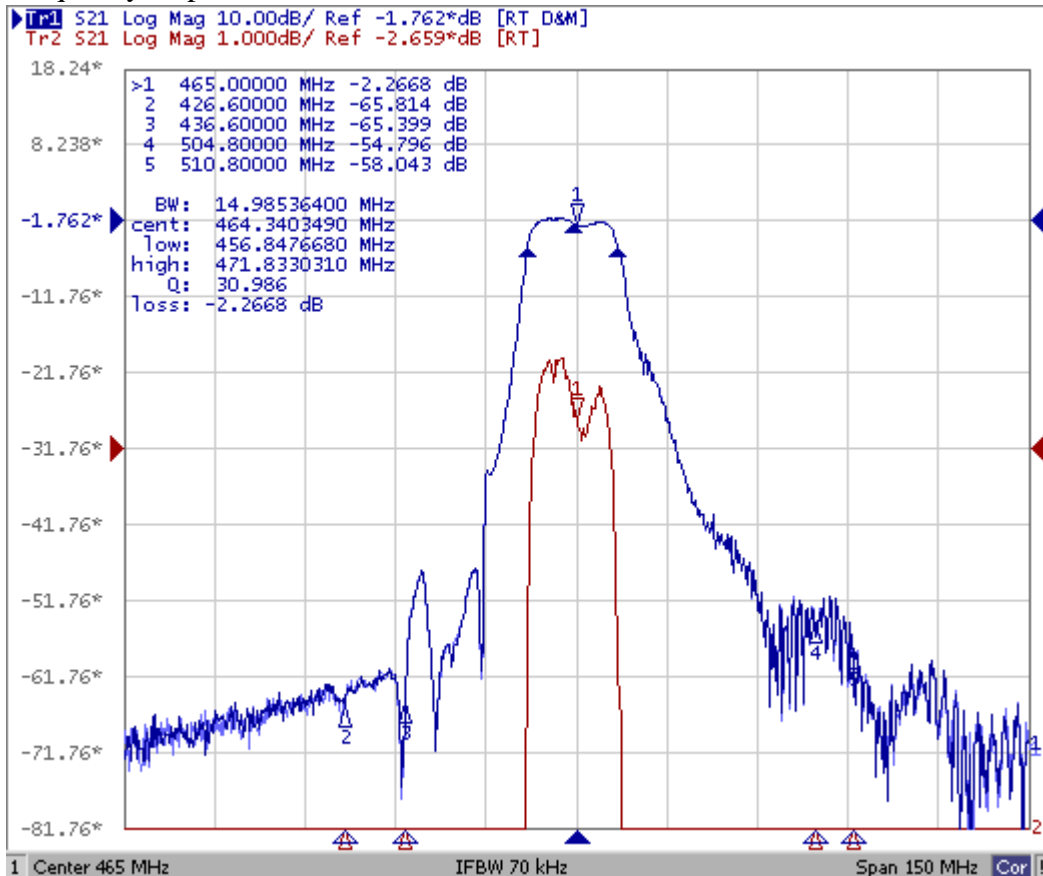

## 2-2. Electrical characteristics

Part number	F465A1	Unit
Nominal center frequency (Fo)	465	MHz
Insertion Loss 426.6MHz~436.6 MHz fo fo +39.8~ fo +45.8MHz	50min. 3.5max 45min	dB
Bandwidth (-3dB)	$\pm 5 \sim \pm 7$	MHz
Ripple (with Fo $\pm 5.0$ MHz)	2.0max	dB
Input/Output Impedance(Nominal)	50//0	$\Omega$ /pF

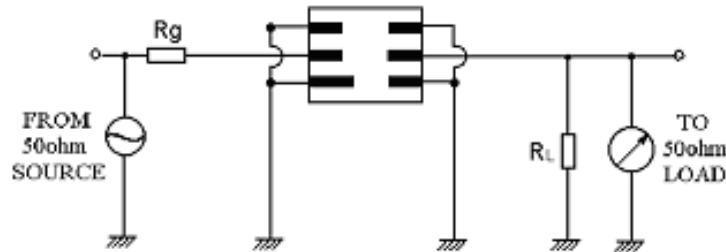
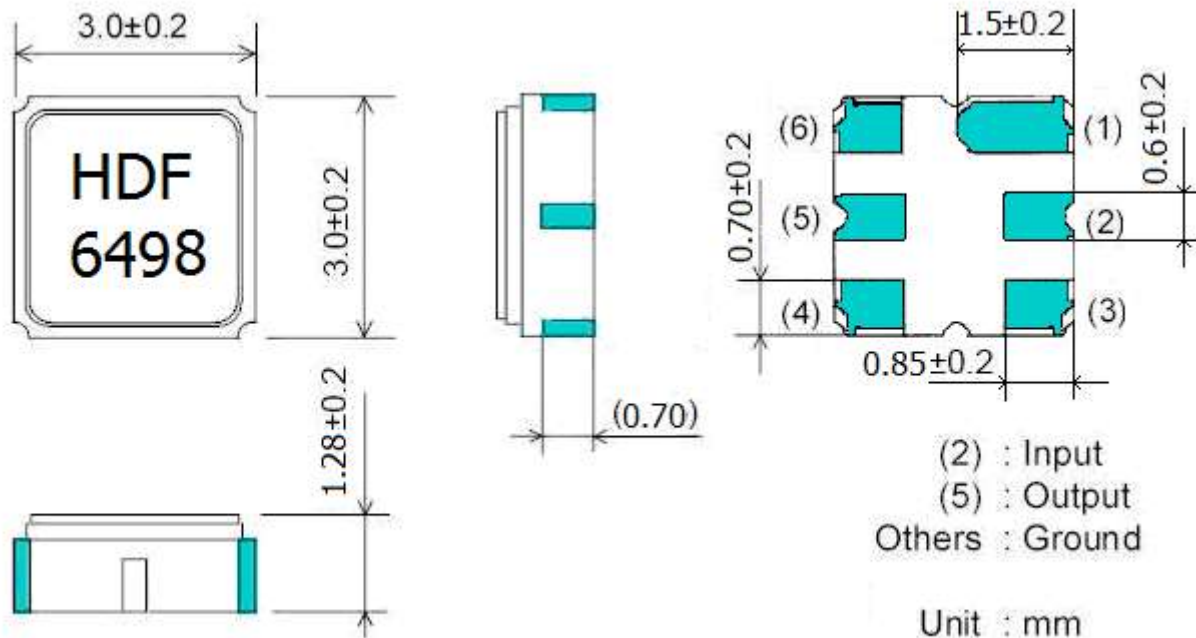
**3. TEST CIRCUIT**

**4. DIMENSION**

**5. ENVIRONMENTAL CHARACTERISTICS**

## 5-1 High temperature exposure

Subject the device to +85°C for 16 hours. Then release the filter into the room conditions for 24 hours prior to the measurement. It shall fulfill the specifications in 2-2.

#### 5-2 Low temperature exposure

Subject the device to -40°C for 16 hours. Then release the device into the room conditions for 24 hours prior to the measurement. It shall fulfill the specifications in 2-2.

#### 5-3 Temperature cycling

Subject the device to a low temperature of -40°C for 30 minutes. Following by a high temperature of +85°C for 30 Minutes. Then release the device into the room conditions for 24 hours prior to the measurement. It shall meet the specifications in 2-2.

#### 5-4 Resistance to solder heat

Dip the device terminals no closer than 1.5mm into the solder bath at 260°C  $\pm 10^\circ\text{C}$  for  $10 \pm 1$  sec. Then release the device into the room conditions for 4 hours. The device shall meet the specifications in 2-2.

#### 5-5 Solderability

Subject the device terminals into the solder bath at 245°C  $\pm 5^\circ\text{C}$  for 5s, More than 95% area of the terminals must be covered with new solder. It shall meet the specifications in 2-2.

#### 5-6 Mechanical shock

Drop the device randomly onto the concrete floor from the height of 1m 3 times. the device shall fulfill the specifications in 2-2.

#### 5-7 Vibration

Subject the device to the vibration for 1 hour each in x,y and z axes with the amplitude of 1.5 mm at 10 to 55 Hz. The device shall fulfill the specifications in 2-2.

## 6. REMARK

#### 6.1 Static voltage

Static voltage between signal load & ground may cause deterioration & destruction of the component. Please avoid static voltage.

#### 6.2 Ultrasonic cleaning

Ultrasonic vibration may cause deterioration & destruction of the component. Please avoid ultrasonic cleaning

#### 6.3 Soldering

Only leads of component may be soldered. Please avoid soldering another part of component.

## 7. Packing

#### 7.1 Dimensions

(1) Carrier Tape: Figure 1

(2) Reel: Figure 2

(3) The product shall be packed properly not to be damaged during transportation and storage.

#### 7.2 Reeling Quantity

1000 pcs/reel 7”  
 3000 pcs/reel 13”

**7.3 Taping Structure**

(1) The tape shall be wound around the reel in the direction shown below.

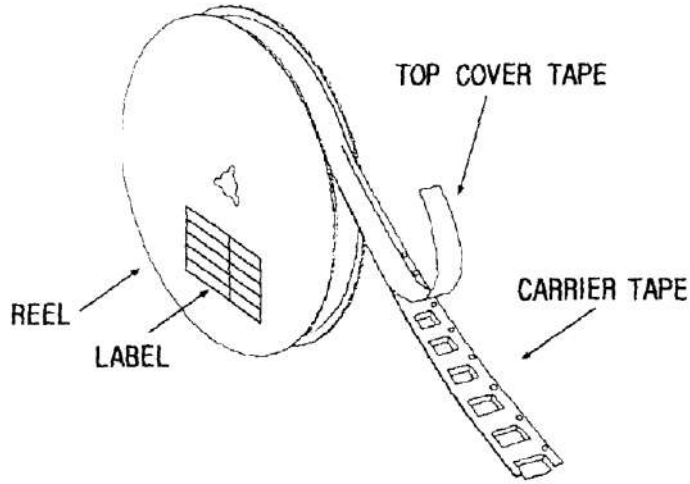

(2) Label

Device Name	
User Product Name	
Quantity	
Lot No.	

(3) Leader part and vacant position specifications.

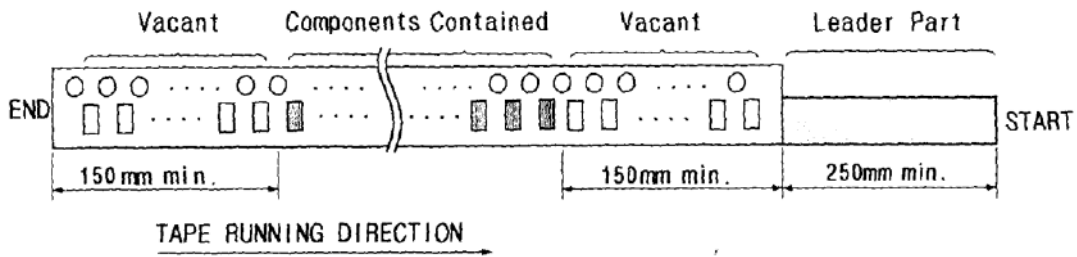

**8. TAPE SPECIFICATIONS**

8.1 Tensile Strength of Carrier Tape: 4.4N/mm width

8.2 Top Cover Tape Adhesion (See the below figure)

- (1) pull off angle: 0~15°
- (2) speed: 300mm/min.
- (3) force: 20~70g

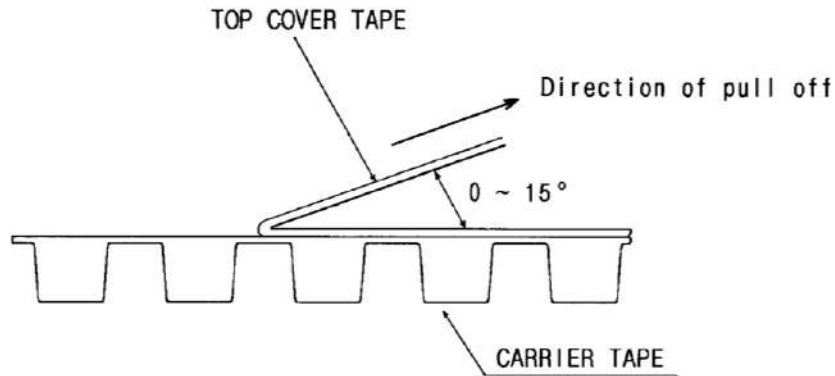

[Figure 1] Carrier Tape Dimensions

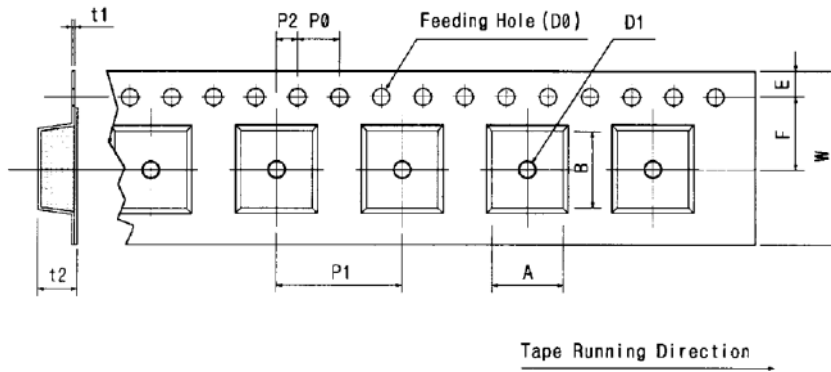

[Unit:mm]

W	F	E	P0	P1	P2	D0	D1	t1	t2	A	B
12.0	5.5	1.75	4.0	8.0	2.0	Ø1.5	Ø1.0	0.3	2.10	6.40	5.20
±0.3	±0.05	±0.1	±0.1	±0.1	±0.05	±0.1	±0.25	±0.05	±0.1	±0.1	±0.1

[Figure 2]

[Unit:mm]

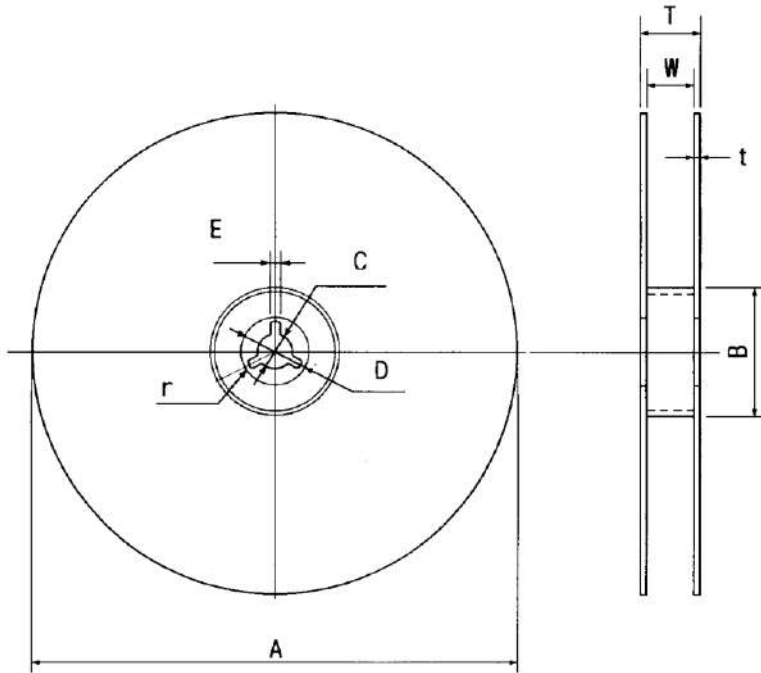

A	B	C	D	E	W	t	r
Ø330	Ø100	Ø13	Ø21	2	13	3	1.0
±1.0	±0.5	±0.5	±0.8	±0.5	±0.3	max.	max.