

规格书编号

SPEC NO : HDF1789A1S4SP01

产品规格书

SPECIFICATION

CUSTOMER 客户: _____
PRODUCT 产品: _____ SAW FILTER _____
MODEL NO 型号: _____ HDF1789A1-S4 _____
MARKING 印字: _____ HDF4G331 _____
PREPARED 编制: _____ CHECKED 审核: _____
APPROVED 批准: _____ D A T E 日期: _____ 2012-6-28 _____

客户确认 CUSTOMER RECEIVED:		
审核 CHECKED	批准 APPROVED	日期 DATE

无锡市好达电子有限公司
Shoulder Electronics Limited

1. Features

SAW filter for GPS.

- High stability and reliability with good performance and no adjustment.
- Narrow and sharp pass band characteristics.
- Low insertion loss and deep stop band attenuation for interference.
- Low – loss SAW filter for GPS.

2. ELECTRICAL SPECIFICATION

Items	Rating	unit
Maximum Working Voltage	0	V _{dc}
Maximum Working Power	10	dBm
Operating Temperature Range	-40 ~ +85	°C
Storage Temperature Range	-50 ~ + 100	°C

Electronic Characteristics

2-1. Typical frequency response

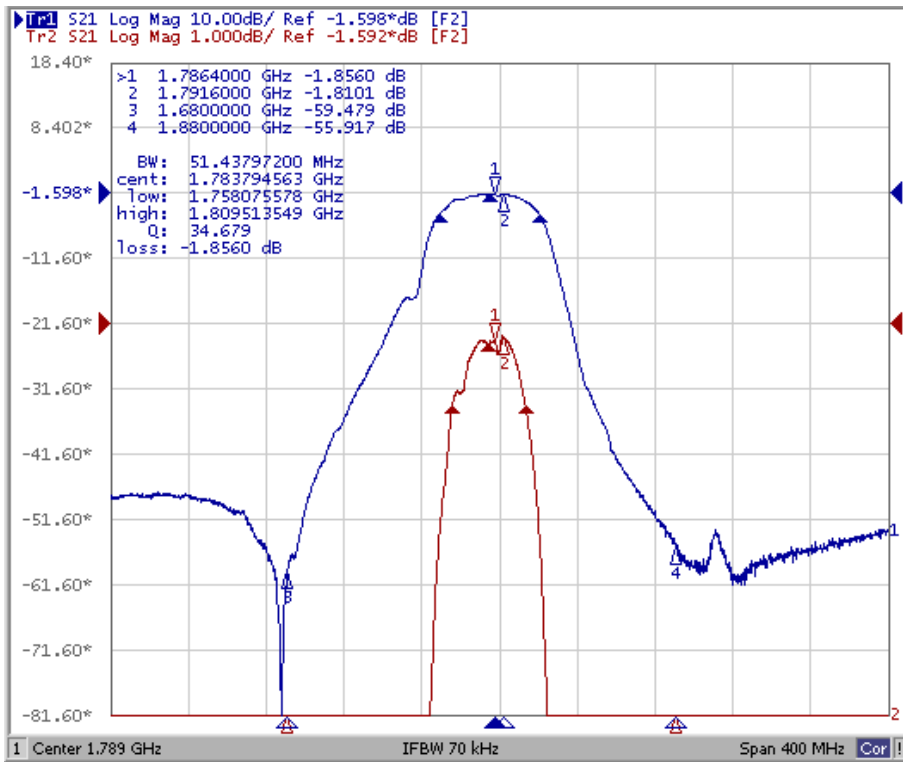

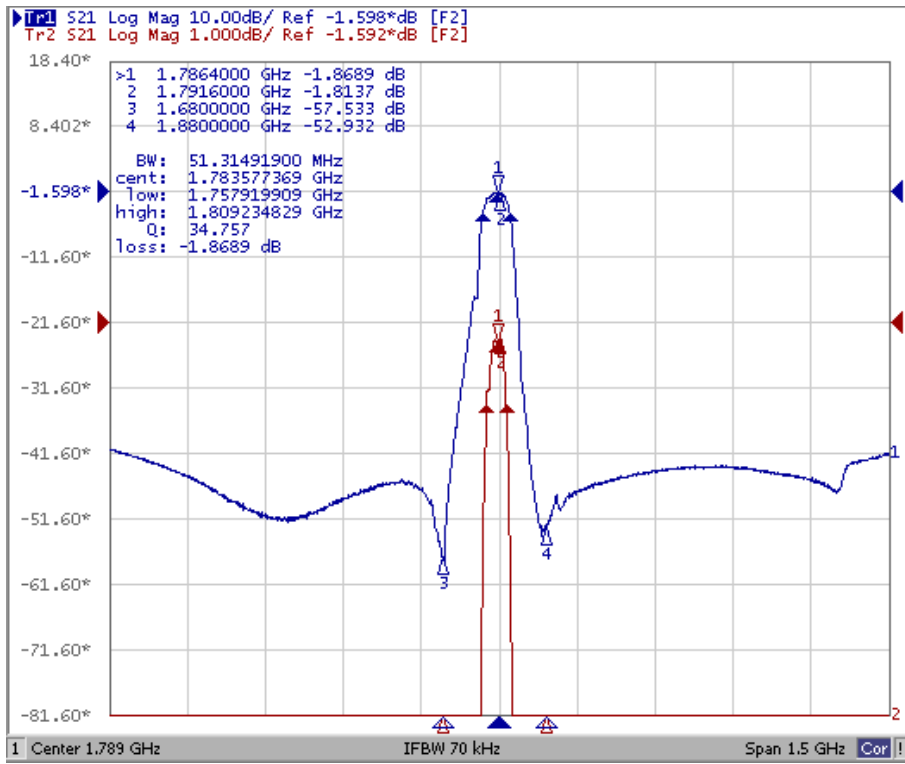

2-2.Electrical characteristics

Items	Test Condition	Min	Typ	Max	Unit
Center Frequency	-	-	1789.35	-	MHz
Insertion Loss	F0 ± 2.6 MHz	-	1.5	3.0	dB
Ripple Level	F0 ± 2.6 MHz	-	0.15	1.0	dB
Attenuation	D.C~1300MHz	30	35	-	dB
	1300~1680MHz	40	45	-	dB
	1880~2400MHz	38	42	-	dB
	2400~3000MHz	30	37	-	dB
VSWR	F0 ± 2.6MHz	-	1.2	2.0	-
Input/Output Impedance	-	-	50	-	ohm

3. TEST CIRCUIT

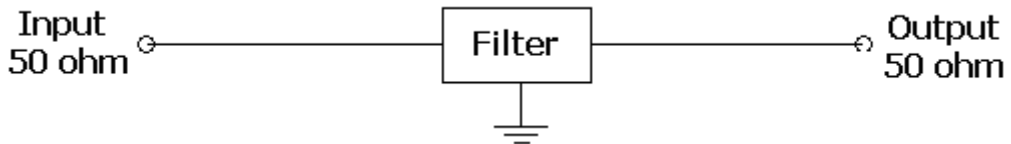

4. DIMENSION

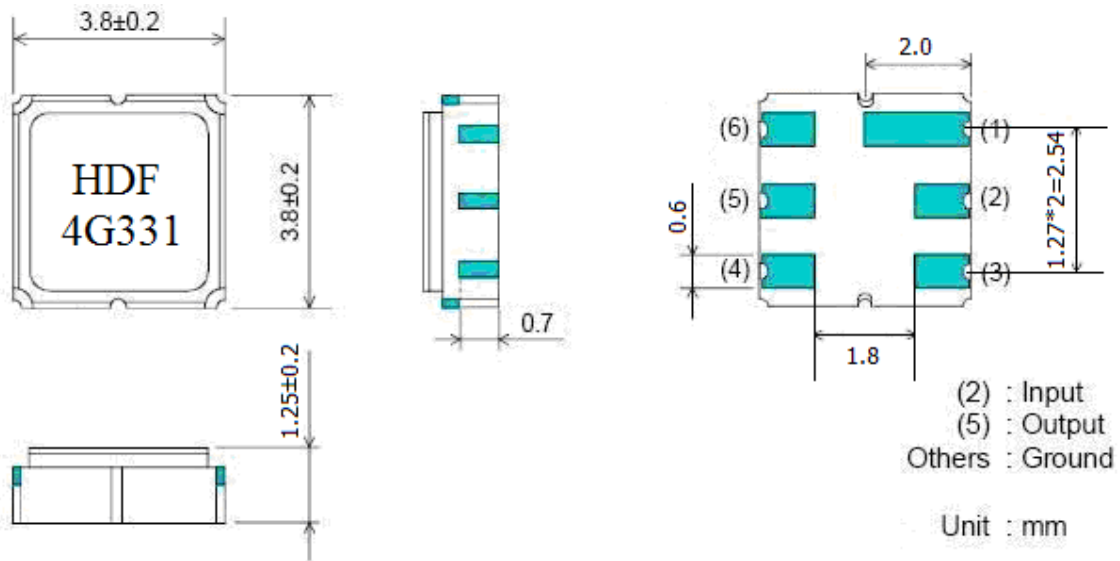

5. ENVIRONMENTAL CHARACTERISTICS

5-1 Temperature cycling

Subject the device to a low temperature of -40°C for 30 minutes. Following by a high temperature of $+25^{\circ}\text{C}$ for 5 Minutes and a higher temperature of $+80^{\circ}\text{C}$ for 30 Minutes. Then release the device into the room conditions for 1 to 2 hours prior to the measurement. It shall meet the specifications in 2-2.

5-2 Resistance to solder heat (耐焊接热)

- 1、immerge the solder bath at 260°C for 10 sec. (浸入 260°C 焊锡槽 10 秒)
- 2、the iron at 370°C for 3 sec (烙铁 370°C 3 秒)

5-3 Solderability (可焊性)

Submerge the device terminals into the solder bath at $245^{\circ}\text{C} \pm 5^{\circ}\text{C}$ for 5s, More than 95% area of the soldering pad must be covered with new solder. It shall meet the specifications in 2-2. (浸没在温度 $245^{\circ}\text{C} + 5 / - 0^{\circ}\text{C}$ 的焊锡中, 持续 3 秒, 焊锡覆盖面积大于 95%)

5-4 Reflow soldering (回流焊)

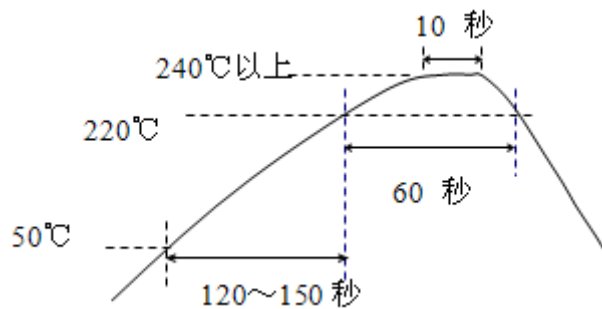

The specimen shall be passed through the reflow furnace with the condition shown in the above profile for 1 time.

The specimen shall be stored at standard atmospheric conditions for 1h, after which

the measurement shall be made. Test board shall be 1.6 mm thick. Base material shall be glass fabric base epoxy resin.

5-5 Mechanical shock

Drop the device randomly onto the concrete floor from the height of 1 m 3 times. the filter shall fulfill the specifications in 2-2.

5-6 Vibration

Subject the device to the vibration for 2 hour each in x,y and z axes with the amplitude of 1.5 mm at 10 to 55 hz. The filter shall fulfill the specifications in 2-2.

6. REMARK

6.1 Static voltage

Static voltage between signal load & ground may cause deterioration & destruction of the component. Please avoid static voltage.

6.2 Ultrasonic cleaning

Ultrasonic vibration may cause deterioration & destruction of the component. Please avoid ultrasonic cleaning

6.3 Soldering

Only leads of component may be soldered. Please avoid soldering another part of component.

7. Packing

7.1 Dimensions

- (1) Carrier Tape: Figure 1
- (2) Reel: Figure 2
- (3) The product shall be packed properly not to be damaged during transportation and storage.

7.2 Reeling Quantity

1000 pcs/reel	7''
3000 pcs/reel	13''

7.3 Taping Structure

- (1) The tape shall be wound around the reel in the direction shown below.

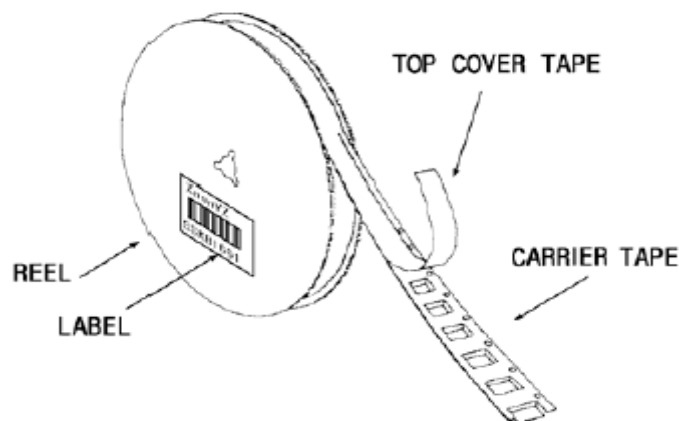

(2) Label

Device Name	
User Product Name	
Quantity	
Lot No.	

(3) Leader part and vacant position specifications.

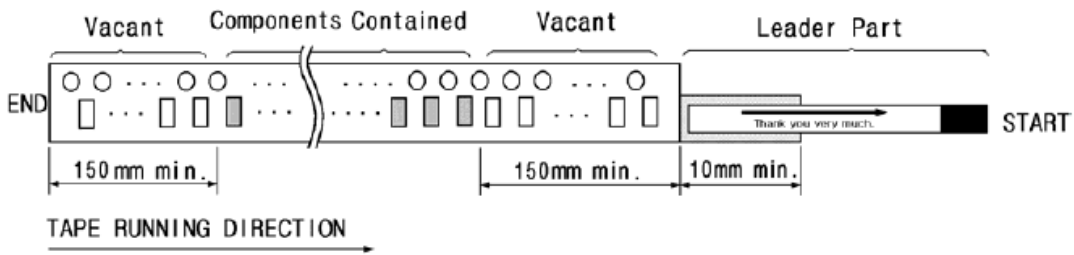

8. TAPE SPECIFICATIONS

8.1 Tensile Strength of Carrier Tape: 4.4N/mm width

8.2 Top Cover Tape Adhesion (See the below figure)

- (1) pull off angle: 0~15°
- (2) speed: 300mm/min.
- (3) force: 20~70g

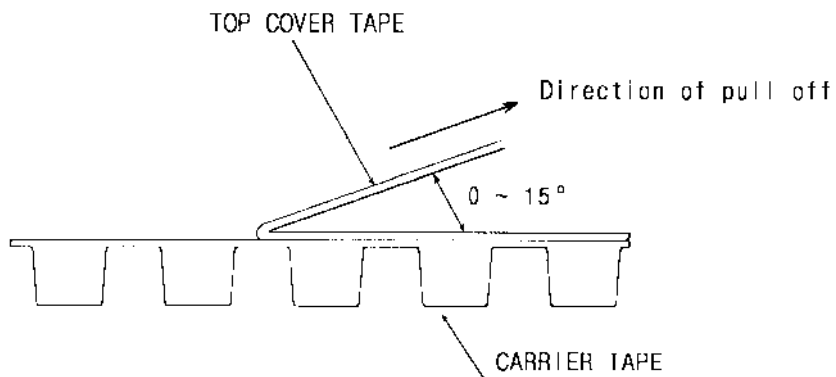

[Figure 1] Carrier Tape Dimensions

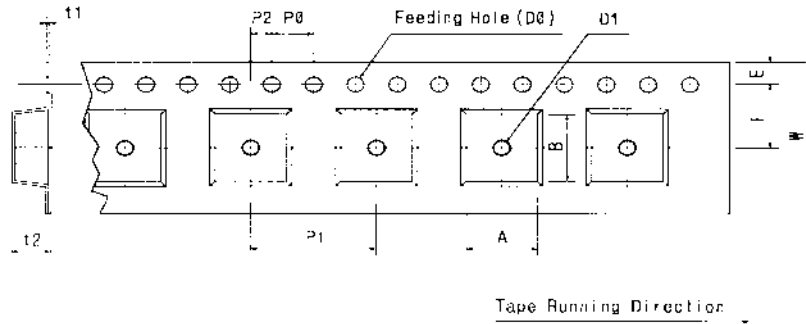

[Unit:mm]

W	F	E	P0	P1	P2	D0	D1	t1	t2	A	B
12.00	5.50	1.75	4.00	4.00	2.00	Ø1.50	Ø1.5	0.31	1.30	3.4	3.4
±0.30	±0.10	±0.10	±0.10	±0.10	±0.10		±0.25	±0.05	±0.10	MAX.	MAX

[Figure 2]

[Unit:mm]

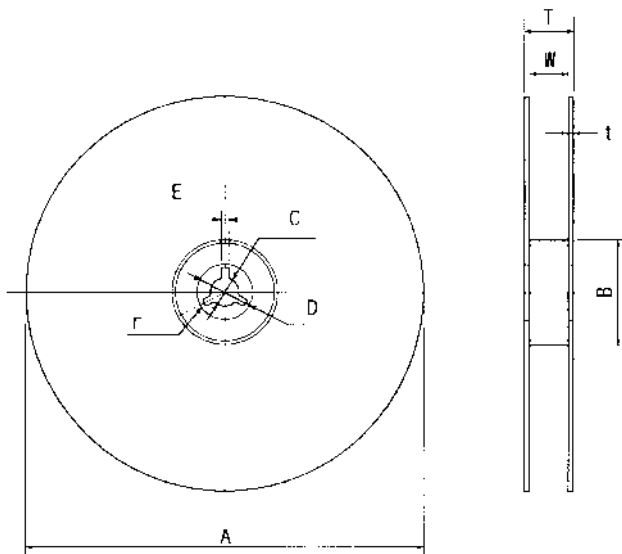

A	B	C	D	E	W	t	r
Ø330	Ø100	Ø13	Ø21	2	13	3	1.0
±1.0	±0.5	±0.5	±0.8	±0.5	±0.3	max.	max.