

1.SCOPE

This specification shall cover the characteristics of SAW Duplexer used for the cordless phone.

2.Construction

2.1 Dimension and materials

Manufacturer's name : SHOULDER ELECTRONICS LTD.

Type : D26/41

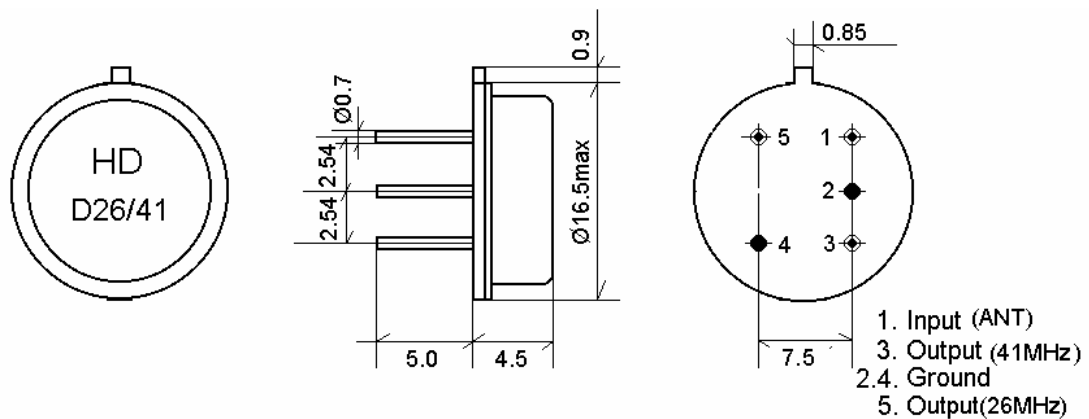

3.Characteristics

Standard atmospheric conditions

Unless otherwise specified, the standard range of atmospheric conditions for making measurements and tests is as follows;

Ambient temperature : 15 to 35

Relative humidity : 25% to 85%

Air pressure : 86kPa to 106kPa

Operating temperature rang

Operating temperature rang is the range of ambient temperatures in which the filter can be

operated continuously. -10 ~ +50

Storage temperature rang

Storage temperature rang is the range of ambient temperatures at which the filter can be stored

without damage.

Conditions are as specified elsewhere in these specifications. -40 ~ +70

Reference temperature +25

3.1 Maximum Rating

DC voltage	V_{DC}	0	V	
Source power	P_s	15	dBm	

3.2 Electrical Characteristics

Characteristics of channel 26:

Source impedance $Z_s=50$

Load impedance $Z_L=50$ $T_A=25$

Item	Freq	min	typ	max	
Nominal frequency	f_N	-	26.40	-	MHz
Insertion attenuation 26.3125~26.4875MHz			6.0	8.0	dB
attenuation	20.00~23.50MHz	30.0	35.0		dB
	41.3125~41.4875MHz	40.0	47.0		dB
	41.4875~80.00MHz	30.0	35.0		dB
Temperature coefficient			-72		ppm/k

Characteristics of channel 41:

Source impedance $Z_s=50$

Load impedance $Z_L=50$ $T_A=25$

Item	Freq	min	typ	max	
Nominal frequency	f_N	-	41.40	-	MHz
Insertion attenuation 41.3125~41.4875MHz			4.0	5.0	dB
attenuation	20.00~26.3125MHz	30.0	35.0		dB
	26.3125~26.4875MHz	40.0	47.0		dB
	44.50~80.00MHz	30.0	35.0		dB
Temperature coefficient			-72		ppm/k

Isolation between 26 and 41:

Source impedance $Z_s=50$

Load impedance $Z_L=50$ $T_A=25$

Item	Freq	min	typ	max	
attenuation	26.3125~26.4875MHz	40.0	48.0		dB
	41.3125~41.4875MHz	38.0	44.0		dB

3.3 Environmental Performance Characteristics

Item Test condition	Allowable change of absolute Level at center frequency(dB)
High temperature test 70 16H ,	< 1.0
Low temperature test	< 1.0

SHOULDER ELECTRONICS LIMITED

-25 2H	
Humidity test 40 90-95% 100H	< 1.0
Thermal cycle -25 ==70 3cycle 30min. 5min. 30min.	< 1.0
Solder temperature test Sold temp.260 for 10 sec.	< 1.0
Soldering Immerse the pins melt solder At 260 +5/-0 for 5 sec.	More then 95% of total area of the pins should be covered with solder

3.4 Mechanical Test

Item Test condition	Allowable change of absolute Level at center frequency(dB)
Vibration test Frequency 10~55Hz amplitude 1.5mm 3 directions 2 H each	<1.0
Drop test On maple plate frome 1 m high 3 times	<1.0
Lead pull test Pull with 1 kg force for 30 seconds	<1.0
Lead bend test 90° bending with 500g weigh 2 times	<1.0

3.5 Voltage Discharge Test

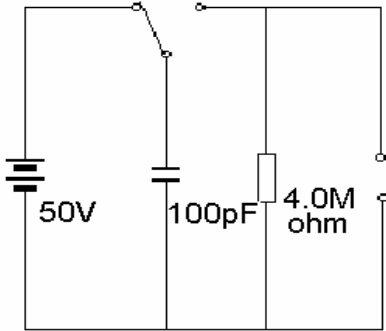
Item Test condition	Allowable change of absolute Level at center frequency(dB)
Surge test Between any two electrode 	<1.0