

# SMD Crystal Resonators / MHz Band Crystal Resonators

## DSX530GA

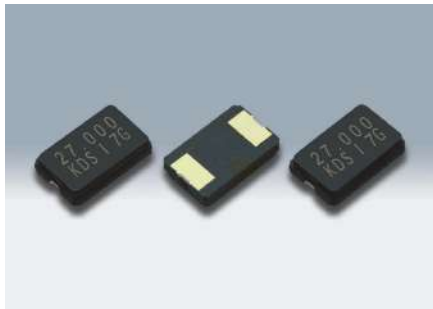

RoHS Compliant



Actual size 

### ■ Features

- 5032 size miniature SMD crystal resonator with a low profile of 1.0mm.
- Excellent heat resistance, high precision, and high reliability.
- Offers a wide frequency range from a comparatively low 7MHz up to 70MHz.
- Suitable for PDA, car navigation systems, digital AV equipment as well as many other applications.

### ■ Standard Specification

Item	Type	DSX530GA				
		7~9MHz	9~12MHz	12~40MHz	40~54MHz	45~70MHz
Frequency Range		7~9MHz	9~12MHz	12~40MHz	40~54MHz	45~70MHz
Overtone Order		Fundamental				3rd overtone
Load Capacitance		Series, 8pF, 10pF, 12pF				Series
Drive Level		10μW (300μW max.)				10μW (500μW max.)
Frequency Tolerance		±30×10 <sup>-6</sup> , ±50×10 <sup>-6</sup> , ±100×10 <sup>-6</sup> (at 25°C)			±50×10 <sup>-6</sup> , ±100×10 <sup>-6</sup> (at 25°C)	±30×10 <sup>-6</sup> , ±50×10 <sup>-6</sup> , ±100×10 <sup>-6</sup> (at 25°C)
Series Resistance		150Ω max.	100Ω max.	50Ω max.		100Ω max.
Frequency Characteristics over Temperature		±30×10 <sup>-6</sup> / -10~+60°C (Ref. to 25°C)				
		±50×10 <sup>-6</sup> / -20~+70°C (Ref. to 25°C)				
		±100×10 <sup>-6</sup> / -30~+85°C (Ref. to 25°C)				
Storage Temperature Range		-40~+85°C				
Packing Unit		1000pcs./reel (φ180)				
Standard Specification		Refer to page 36				

Consult our sales representative for other specifications.

### ■ Dimensions [mm]

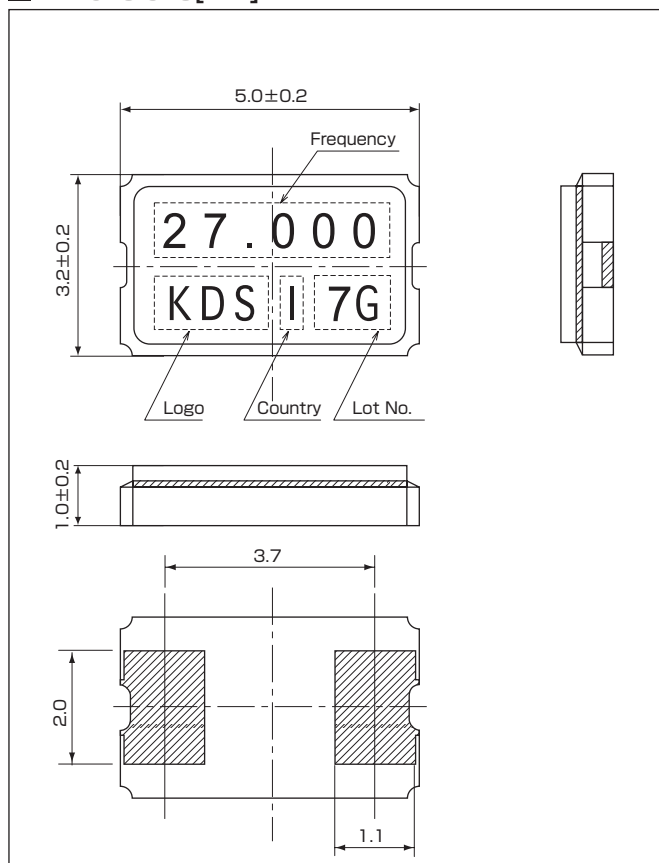

### ■ Internal Connections

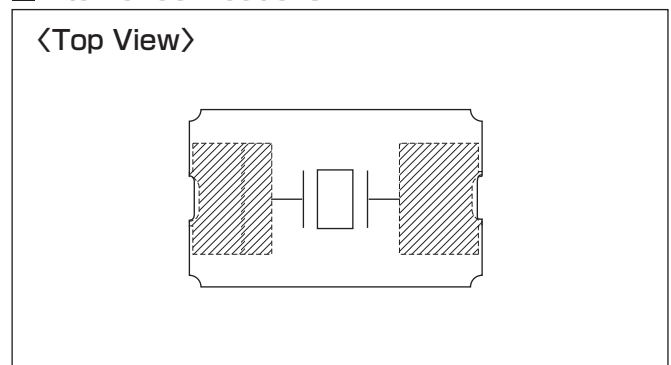

### ■ Recommended Land Pattern [mm]

