

FMOC71 SERIES

5.0 Vdc Clock Oscillators

14 PIN DIP



- High Frequency via Multiplier*
- 3.3 Vdc Supply Voltage Option
- HCMOS/TTL Compatible
- Lower Cost*

SPECIFICATIONS

Parameter	Specification												
Frequency Range	60.0 to 160.0 MHz (100MHz max @ +3.3 Vdd)												
Overall Frequency Tolerance	±20 ppm to ±100 ppm (Inclusive of Operating Temp., Supply Voltage, & Load)												
Operating Temperature Range	0 to +70 °C Std. (See Temp. Range Options)												
Storage Temperature	-55 to +125 °C												
Supply Voltage (Vdd)	+5.0 Vdc (±0.5 Vdc) or +3.3 Vdc (±0.3 Vdc)												
Supply Current (Icc)	30 mA max. @ 60.0 to 99.9 MHz 50 mA max. @ 100.0 to 149.9 MHz 60 mA max. @ 150.0 to 160.0 MHz												
Symmetry (Duty Cycle)	40/60% Std., 45/55% Avail. (See Spec. Option S)												
Output "0" Level (Vol)	0.4 Vdc max. (TTL) 0.5 Vdc max. (HCMOS) (0.3 Vdc max @ +3.3 Vdd)												
Output "1" Level (Voh)	2.4 Vdc min. (TTL) 4.5 Vdc min. (HCMOS) (3.0 Vdc min @ +3.3 Vdd)												
Rise and Fall Time	10 ns max. < 5 ns typical												
Start Time	10 ms max. < 5 ms typical												
Output Load	10 TTL / 15 pF HCMOS												
Jitter (typical)	< 25 pico seconds, one sigma												
Phase Noise (typical)	<table border="1"> <tr> <td>10 Hz</td> <td>-75dBc/Hz</td> </tr> <tr> <td>100 Hz</td> <td>-105dBc/Hz</td> </tr> <tr> <td>1kHz</td> <td>-100dBc/Hz</td> </tr> <tr> <td>10kHz</td> <td>-90dBc/Hz</td> </tr> <tr> <td>100kHz</td> <td>-95dBc/Hz</td> </tr> <tr> <td>1MHz</td> <td>-120dBc/Hz</td> </tr> </table>	10 Hz	-75dBc/Hz	100 Hz	-105dBc/Hz	1kHz	-100dBc/Hz	10kHz	-90dBc/Hz	100kHz	-95dBc/Hz	1MHz	-120dBc/Hz
10 Hz	-75dBc/Hz												
100 Hz	-105dBc/Hz												
1kHz	-100dBc/Hz												
10kHz	-90dBc/Hz												
100kHz	-95dBc/Hz												
1MHz	-120dBc/Hz												
Pin 1 Options (See Spec. Option T below)	No Connect (Std.) Tri-State (option T) VIH: 2.2 V or Open Enables Output VIL: 0.8 V Disables Output Output Disable/Enable Time: 100 nS max.												
Aging @ 25 °C	±5ppm max first year												

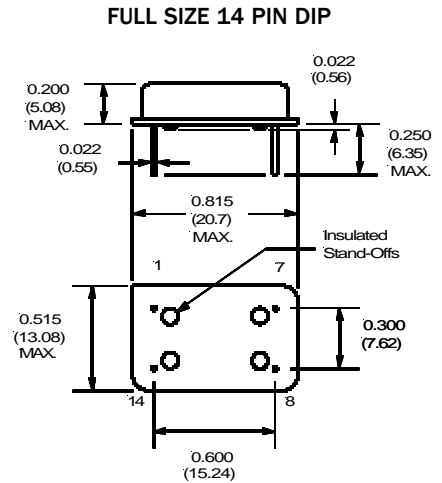

PIN FUNCTION TABLE

Pin	Function
1	NC or Tri-State
7	Case Ground
8	Output
14	Supply Voltage (Vdd)

* All specifications for 5.0 Vdc supply voltage unless otherwise noted.
All specifications subject to change without notice.

NOTE: Waveforms & Test Circuits on pages 48, 49

Standard Specifications for product indicated in color

Dimensions: $\frac{\text{Inches}}{\text{(mm)}}$

PART NUMBERING SYSTEM

MARKING: See Page 57, Format G

FMOC71 00 A 3/S/T - XXXXXXXXM - CM

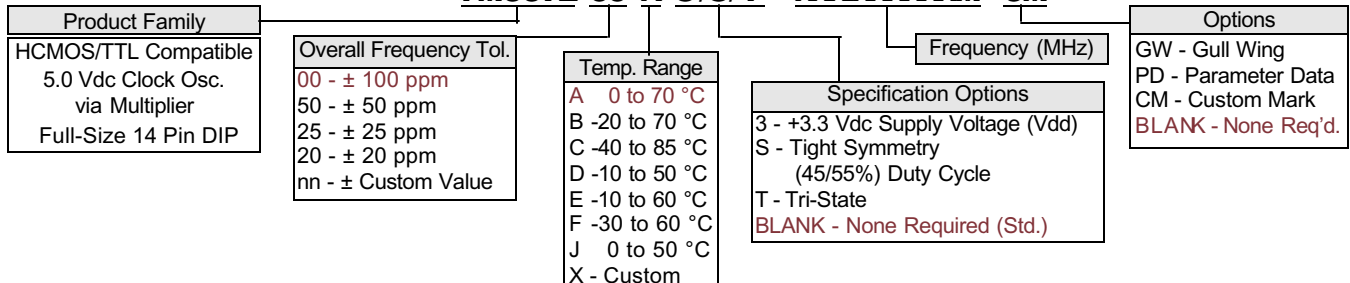

15302 Bolsa Chica St., Huntington Beach, CA. 92649
 Tel: 714-892-3234 Fax: 714-890-1832
 E-mail: sales@frequencymanagement.com
 www.frequencymanagement.com

1-800-800-XTAL
(9825)