



CY WIRELESS TECHNOLOGY LIMITED

SPECIFICATION FOR APPROVAL

CUSTOMER	_____
NOMINAL FREQUENCY	13.52127MHz
HOLDER TYPE	3225
SPEC. NO. (P/N)	13.52127S3
CUSTOMER P/N	_____
ISSUE DATE	_____

Add: 1407, Block C, Tairan Building, 8th
Tairan Road, Futian District, Shenzhen,
Guangdong, China
TEL: 0086-755-23937707
FAX: 0086-755-88351759
www.rficy.com

1. ELECTRICAL SPECIFICATIONS

Parts Number : 13.52127S3

Item	Symbol	Specifications				Notes
		Min	Type	Max	Units	
Nominal frequency	FO	13.521270			MHz	
Mode of Oscillation	OT	Fundamental				
Load Capacitance	LC	10			pF	
Frequency Tolerance	FT	± 15			ppm	at 25°C ± 3°C
Frequency Stability		± 20			ppm	with working temperature Reference to 25°C
Working temperature range	TR	-20~70			°C	
Drive Level	DL	100			µW	Max.
Series Resonant Resistance RR	CI/RR	60			Ω	Max.
Insulation Resistance	IR	>500			MΩ	
Shunt Capacitance C0	C0	7			pF	
Aging		3			ppm/yr.	
Storage temperature range		-55 ~ 125			°C	
Unit Weight					g	

2. MARKING

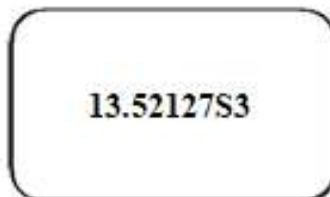

3. RELIABILITY SPECIFICATIONS

NO.	TEST ITEM	TEST METHODS	
1	DROP TEST	Device are dropped from a height of 150 cm onto 2 mm thickness stainless plate executing 3 times of random drops.	
2	MECHANICAL SHOCK	Device are shocked to half sine wave (1000 G) three mutually perpendicular axes each 3 times.	
3	VIBRATION	Frequency range	10 ~ 2000 Hz
		Amplitude	1.5 mm
		Sweep Time	20 minute
		Test Time	2 hours
4	SOLDERABILITY	MIL - STD - 20E Method 208C	
		Temperature	245°C±5°C
		Material	H63A (Silver 2 ~ 3 %)
		Immersion depth	0.5 mm minimum
		Immersion time	3 ±0.5 seconds
		Flux	Rosin resin methyl alcohol solvent (1 : 4)
5	RESISTANCE TO SOLDERING HEAT	MIL - SLD -202, Method 210, Condition I or J 10 sec immersion into 260 ± 5°C solder pot, above 180°C is 90 ~ 120 sec.	
6	LOW TEMP. STORAGE	Leave at - 55 °C ± 2°C for 1000 ± 12 hours	
7	HIGH TEMP. STORAGE	Leave at 125 °C ± 2°C for 1000 ± 12 hours	
8	THERMAL SHOCK	Total 100 cycles of the following temperature cycle	

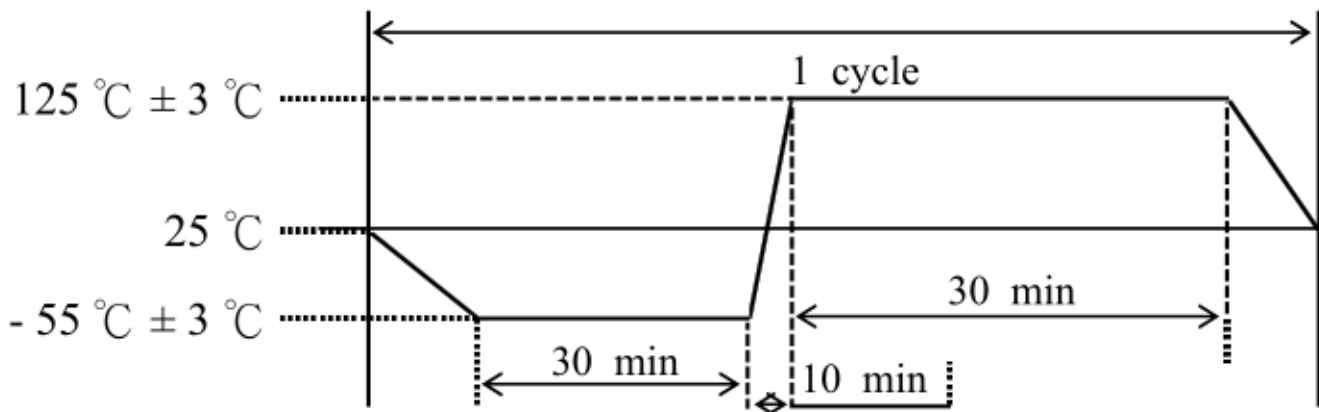

4. DIMENSIONS

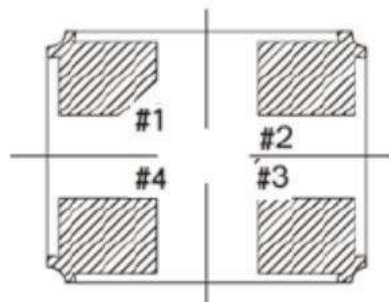
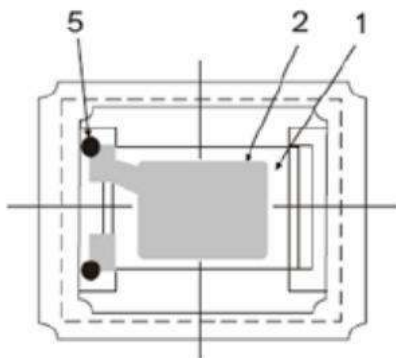
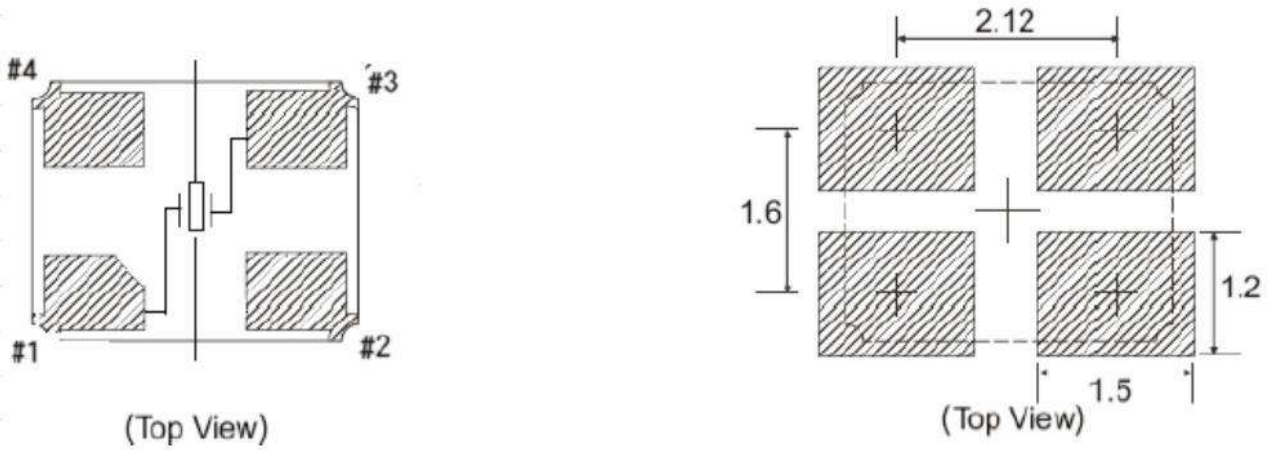
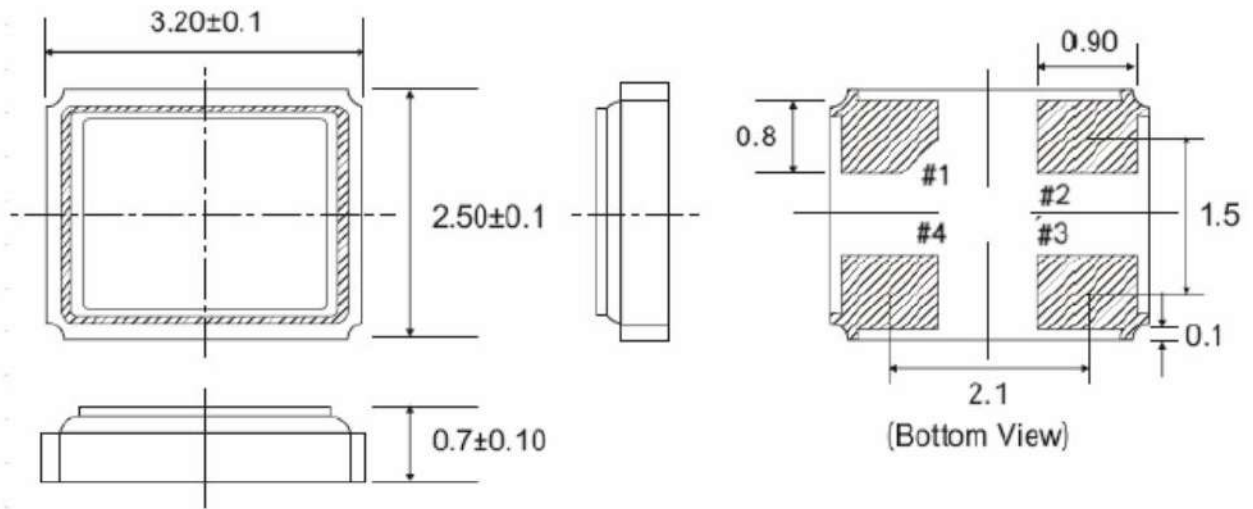

1	Quartz Blank
2	Electrode
3	Lid
4	Base
5	Conductive adhesive

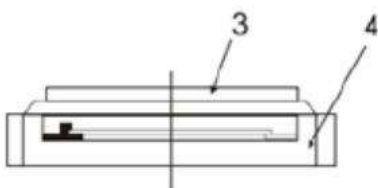

5. SUGGESTED IR REFLOW PROFILE

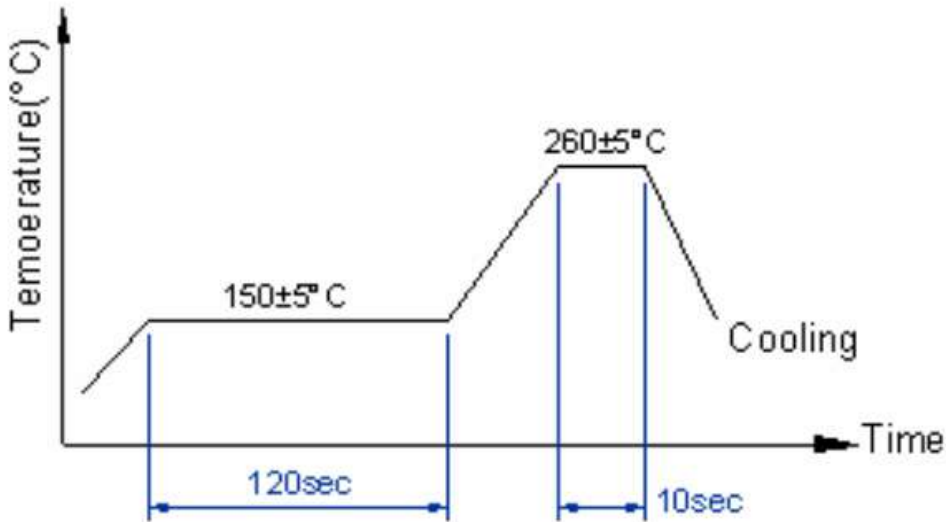

Total Time: 200 Sec.Max

Solder melting point : 185°C

6. PACKING

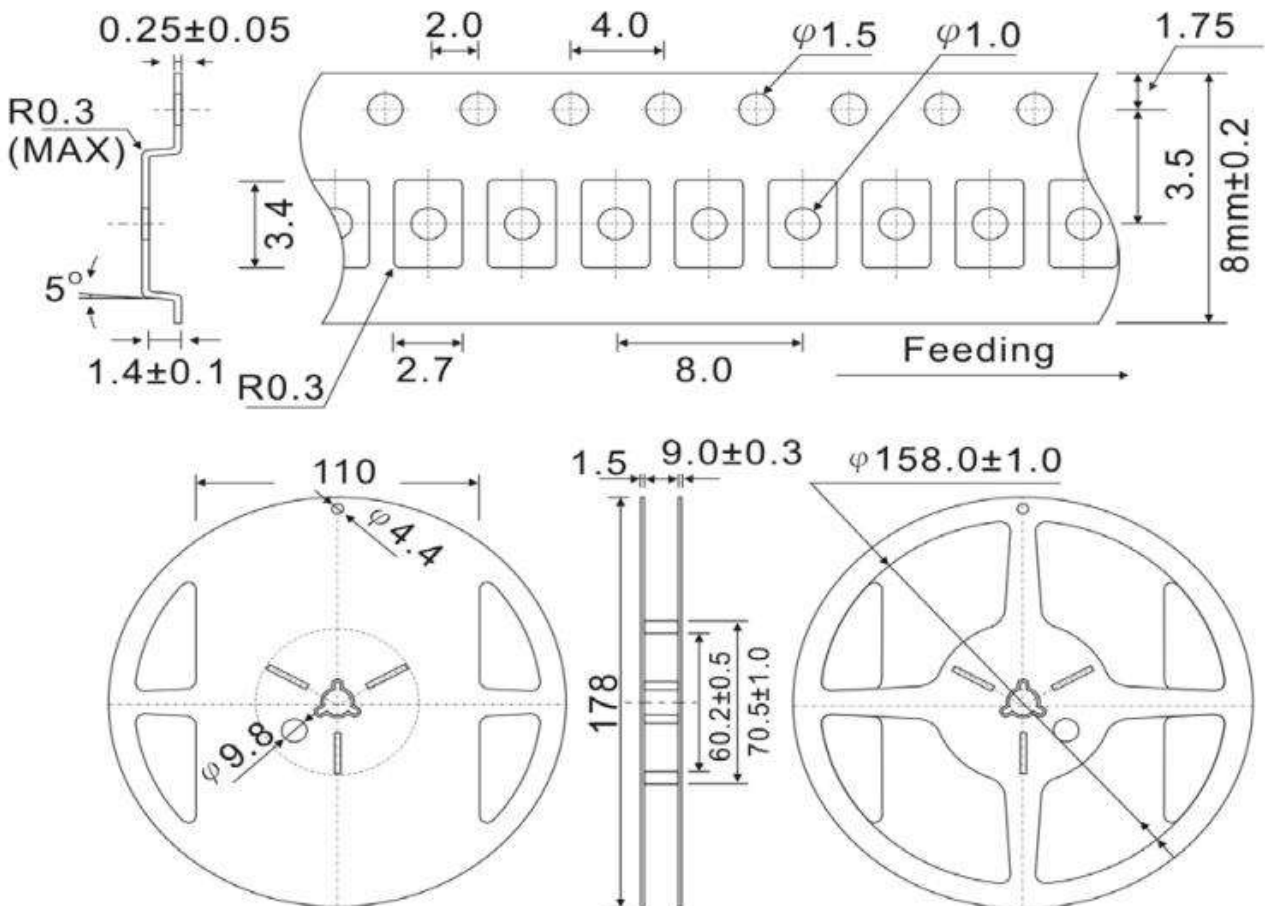

1. 230mm minimum leader which consist of carrier and/or tape followed by a minimum of 160mm of empty carrier tape sealed with cover tape.
2. 160mm minimum trailer of empty carrier tape sealed with cover tape.

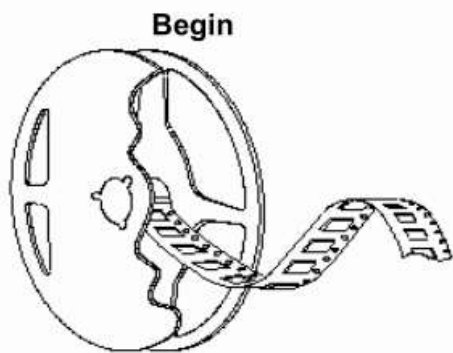

3000pcs-Product Tape

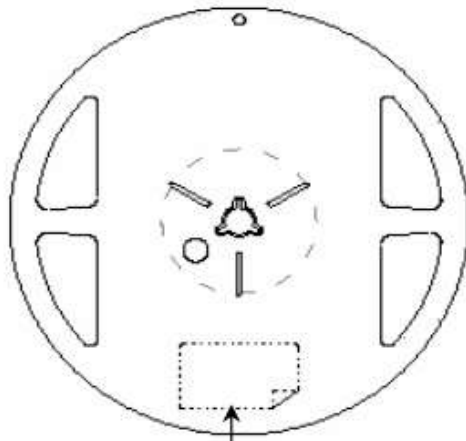
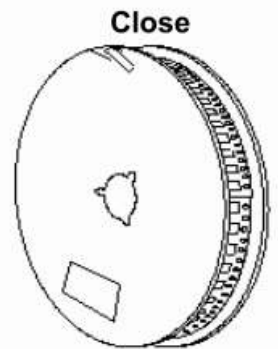
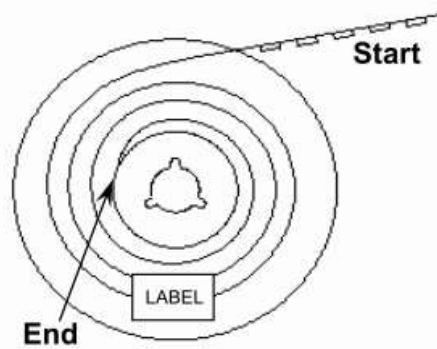

blue qualified label



storeroom label

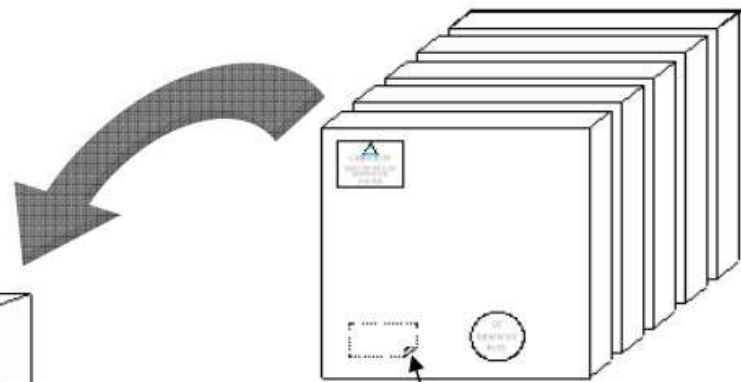

storeroom label

storeroom label

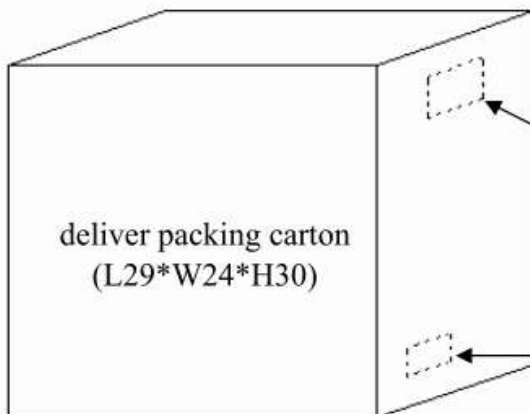

deliver packing carton
(L29*W24*H30)

Green qualified label