



ISO9001 & ISO14001 & TS16949 CHILISIN ELECTRONICS CORP.

Lead-Free & RoHs Compliance!!

SPECIFICATION FOR APPROVAL

CUSTOMER : _____

CUSTOMER P/N : _____

OUR DWG No : _____

QUANTITY : 0 Pcs. DATE : 2012/05/02

ITEM : SCD1005T-SERIES

SPECIFICATION ACCEPTED BY:	
COMPONENT ENGINEER	
ELECTRICAL ENGINEER	
MECHANICAL ENGINEER	
APPROVED	
REJECTED	

<p>奇力新電子股份有限公司 CHILISIN ELECTRONICS CORP. NO.29,LANE 301,TEHHSIN ROAD,HUKOU, HSINCHU,TAIWAN,303, REPUBLIC OF CHINA TEL : (03) 599-2646 FAX : (03) 599-9176 E-mail : Sales@chilisin.com.tw http : //www.chilisin.com.tw</p> <p>台北營業處 Taipei Office 1F., No.2, Aly. 1, Ln. 235, Baoqiao Rd., Xindian Dist., New Taipei City 231, Taiwan TEL : +886-2-6629-5588~9 FAX : +886-2-6629-0088 E-mail : Sales@chilisin.com.tw</p>	<p>東莞奇力新電子有限公司 Chilisin Electronics (Dongguan) Co., Ltd. No. 78, Puxing Rd., Yuliangwei Administration Area, Qingxi Town, Dongguan City, Guangdong,China TEL : +86-769-8773-0251~3 FAX : +86-769-8773-0232 E-mail : cect@chilisin.com.tw</p> <p>奇力新電子(蘇州)有限公司 Chilisin Electronics (Suzhou) Co., Ltd. No.143,Song Shan Rd., Suzhou New District, Suzhou,China Postal Code:215129 TEL:+86-512-6841-2350 FAX:+86-512-6841-2356 E-mail : suzhou@chilisin.com.tw</p>
--	---

DRAWN BY 趙燕玲 annie	CHECKED BY 趙燕玲 annie	APPROVED BY 唐威德 daniel.tang
-----------------------	-------------------------	--------------------------------

SCD1005T Series Specification

1 Scope: This specification applies to SMD POWER CHOKE

2 Part Numbering: Product Identification

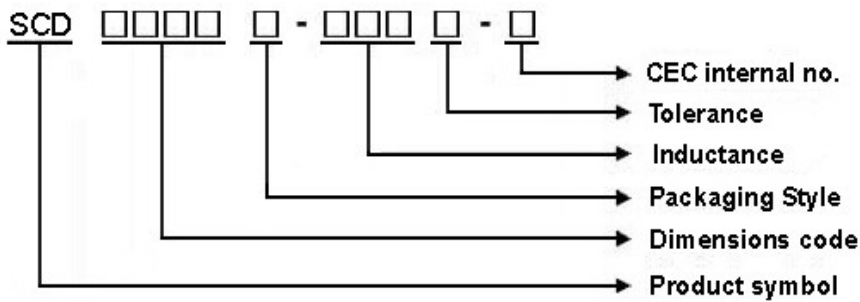

3 Rating:

Operating Temperature: - 4 0 °C ~ 1 0 5 °C (Including self - temperature rise)

Storage Temperature: Under 2 5 °C , Humidity < 75% RH

4 Marking:

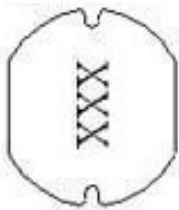

Ex : SCD□□□□T-100M-N

Marking : 100

Marking color : Black

5 Standard Testing Condition

	Unless otherwise specified	In case of doubt
Temperature	Ordinary Temperature(15 to 35°C)	20±2°C
Humidity	Ordinary Humidity(25 to 85% RH)	60 to 70 % RH

SCD1005T Series Specification

6 Configuration and Dimensions:

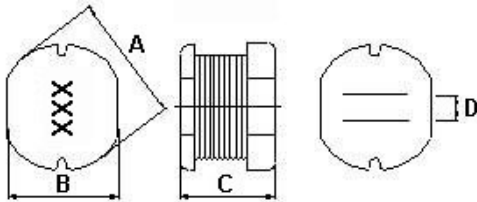

Dimensions in mm

TYPE	SCD1005
A	10.0±0.4
B	9.0±0.4
C	5.4±0.4
D	2.1

7 ELECTRICAL CHARACTERISTICS :

Part No.	Inductance (uH)	Test Freq.	RDC (Ω)Max.	Isat (A)	Tolerance (±%)	Marking
SCD1005T-3R3□-N	3.3	7.96 MHz,1 V	0.038	2.8	20	3R3
SCD1005T-4R7□-N	4.7	7.96 MHz,1 V	0.04	2.6	20	4R7
SCD1005T-5R6□-N	5.6	7.96 MHz,1 V	0.037	4.5	20	5R6
SCD1005T-6R8□-N	6.8	7.96 MHz,1 V	0.037	4.33	20	6R8
SCD1005T-8R2□-N	8.2	7.96 MHz,1 V	0.05	3.5	20	8R2
SCD1005T-100□-N	10	2.52 MHz,1 V	0.06	2.6	10,20	100
SCD1005T-120□-N	12	2.52 MHz,1 V	0.07	2.45	20	120
SCD1005T-150□-N	15	2.52 MHz,1 V	0.08	2.27	10,20	150
SCD1005T-180□-N	18	2.52 MHz,1 V	0.09	2.15	20	180
SCD1005T-220□-N	22	2.52 MHz,1 V	0.1	1.95	10,20	220
SCD1005T-270□-N	27	2.52 MHz,1 V	0.11	1.76	10,20	270
SCD1005T-330□-N	33	2.52 MHz,1 V	0.12	1.5	10,20	330
SCD1005T-390□-N	39	2.52 MHz,1 V	0.14	1.37	10,20	390
SCD1005T-470□-N	47	2.52 MHz,1 V	0.17	1.28	10,20	470
SCD1005T-560□-N	56	2.52 MHz,1 V	0.19	1.17	10,20	560
SCD1005T-680□-N	68	2.52 MHz,1 V	0.22	1.11	10,20	680
SCD1005T-820□-N	82	2.52 MHz,1 V	0.25	1	10,20	820
SCD1005T-101□-N	100	1 kHz,1 V	0.35	0.97	10,20	101
SCD1005T-121□-N	120	1 kHz,1 V	0.4	0.89	10,20	121
SCD1005T-151□-N	150	1 kHz,1 V	0.47	0.78	10,20	151
SCD1005T-181□-N	180	1 kHz,1 V	0.63	0.72	10,20	181
SCD1005T-221□-N	220	1 kHz,1 V	0.73	0.66	10,20	221
SCD1005T-271□-N	270	1 kHz,1 V	0.97	0.57	10,20	271
SCD1005T-331□-N	330	1 kHz,1 V	1.15	0.52	10,20	331
SCD1005T-391□-N	390	1 kHz,1 V	1.3	0.48	10,20	391

NOTE: □-tolerance K=±10% / M=±20%

1.Operating temperature range - 40 °C~ 105 °C(Including self - temperature rise)

2.Isat:Inductance drop =10% typ.

"-N" FOR COMPLETELY LEAD FREE TYPE(INCLUDING FERRITE BODY & SOLDER)



ISO9001 & ISO14001 & TS16949 CHILISIN ELECTRONICS CORP.

SCD1005T Series Specification

Part No.	Inductance (uH)	Test Freq.	RDC (Ω)Max.	Isat (A)	Tolerance ($\pm\%$)	Marking
SCD1005T-471□-N	470	1 kHz,1 V	1.48	0.42	10,20	471
SCD1005T-561□-N	560	1 kHz,1 V	1.9	0.33	10,20	561
SCD1005T-681□-N	680	1 kHz,1 V	2.25	0.28	10,20	681
SCD1005T-821□-N	820	1 kHz,1 V	2.55	0.24	10,20	821
SCD1005T-102□-N	1000	1 kHz,1 V	3.1	0.2	10,20	102

SCD1005T Series Specification

8 SCD1005T Series

8.1 Construction:

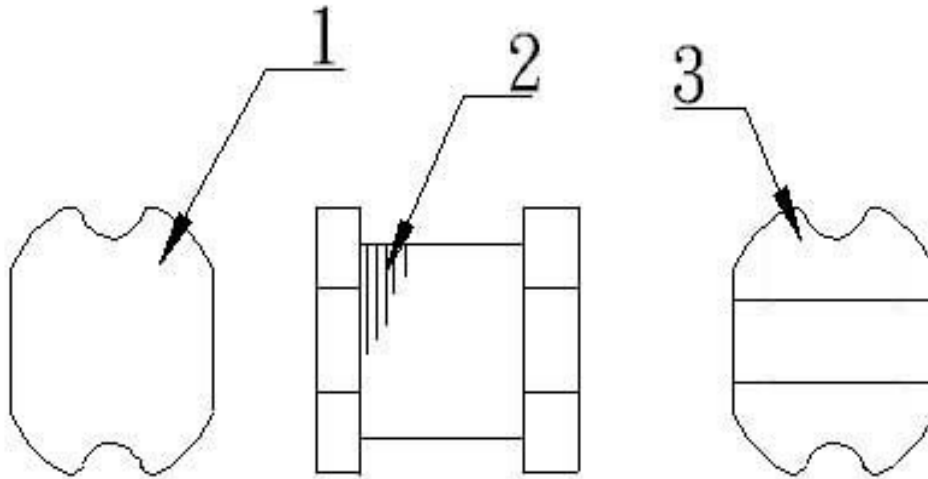

8.2 Material List:

ITEM	PART	DESCRIPTION	SUPPLIES
1	CORE	FERRITE	CHILISIN
2	WIRE	MAGNET WIRE	
3	TERMINAL	Sn/Ag3.0/Cu0.5	Dyfenco



SCD1005T Series Specification

9 Reliability Of Ferrite Wire Wound Power Inductor

1-1.Mechanical Performance

No	Item	Specification	Test Method
1-1-1	Vibration	Appearance: No damage Inductance: within $\pm 10\%$ of initial value	Test device shall be soldered on the substrate Oscillation Frequency: 10 to 55 to 10Hz for 1min Amplitude: 1.5mm Time: 2hrs for each axis (X, Y & Z), total 6hrs
1-1-2	Resistance to Soldering Heat	Appearance: No damage	Pre-heating: 150°C, 1min Solder Composition: Sn/Ag3.0/Cu0.5 Solder Temperature: 260 \pm 5°C Immersion Time: 10 \pm 1sec
1-1-3	Solder ability	The electrodes shall be at least 95% covered with new solder coating	Pre-heating: 150°C, 1min Solder Composition: Sn/Ag3.0/Cu0.5 Solder Temperature: 245 \pm 5°C Immersion Time: 4 \pm 1sec
1-1-4	Resistance to solvent	There must be no change in appearance or obliteration of marking.	Inductors must withstand 6 minutes of alcohol or water.

1-2.Environmental Performance

No	Item	Specification	Test Method															
1-2-1	Temperature Shock	Appearance: No damage Inductance: within $\pm 10\%$ of initial value	10 cycles (Air to Air) 1 cycles shall consist of: 30 minutes exposure to -55 °C 30 minutes exposure to 125 °C 15 seconds maximum transition between temperatures															
1-2-2	Temperature Cycle		One cycle: <table border="1" style="width: 100%; border-collapse: collapse;"> <thead> <tr> <th>Step</th> <th>Temperature (°C)</th> <th>Time (min)</th> </tr> </thead> <tbody> <tr> <td>1</td> <td>-40\pm3</td> <td>30</td> </tr> <tr> <td>2</td> <td>25\pm2</td> <td>3</td> </tr> <tr> <td>3</td> <td>105\pm3</td> <td>30</td> </tr> <tr> <td>4</td> <td>25\pm2</td> <td>3</td> </tr> </tbody> </table>	Step	Temperature (°C)	Time (min)	1	-40 \pm 3	30	2	25 \pm 2	3	3	105 \pm 3	30	4	25 \pm 2	3
Step	Temperature (°C)	Time (min)																
1	-40 \pm 3	30																
2	25 \pm 2	3																
3	105 \pm 3	30																
4	25 \pm 2	3																
1-2-3	Humidity Resistance		Total: 100cycles Measured after exposure in the room condition for 24hrs Temperature: 40 \pm 2°C Relative Humidity: 90 ~ 95% Time: 1000hrs Measured after exposure in the room condition for 24hrs															
1-2-4	Heat Life		Temperature: 85 \pm 3°C Relative Humidity: 20% Applied Current: Rated Current Time: 1000hrs Measured after exposure in the room condition for 24hrs															
1-2-5	Cold Resistance		Temperature: -40 \pm 3°C Relative Humidity: 0% Time: 1000hrs Measured after exposure in the room condition for 24hrs															

SCD1005T Series Specification

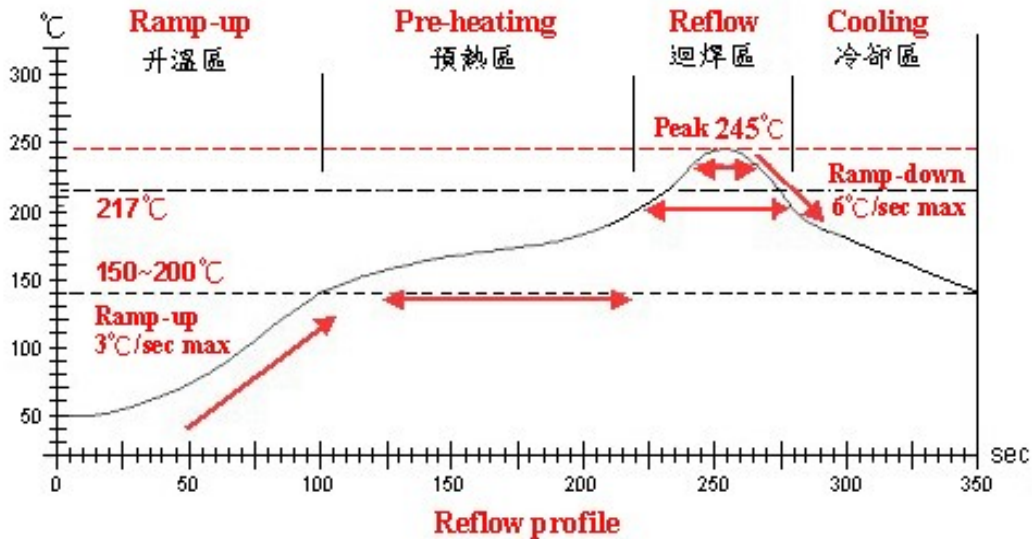

Lead-Free(LF) 標準溫度分析範圍

Refer to J-STD-020C

管制項目 Item.	升温區 Ramp-up	預熱區 Pre-heating	迴焊區 Reflow	Peak Temp	冷卻區 Cooling
溫度範圍 Temp. scope	R.T. ~ 150°C	150°C ~ 200°C	217°C	245±5°C	Peak Temp. ~ 150°C
標準時間 Time spec.	—	60 ~ 180 sec	60 ~ 150 sec	20 ~ 40 sec	—
實際時間 Time result	—	70 ~ 95 sec	70 ~ 95 sec	20 ~ 35 sec	—

SCD1005T Series Specification

11 PACKAGING

11.1 Packaging -Cover tape

The force for tearing off cover tape is 10 to 130 grams in the arrow direction.

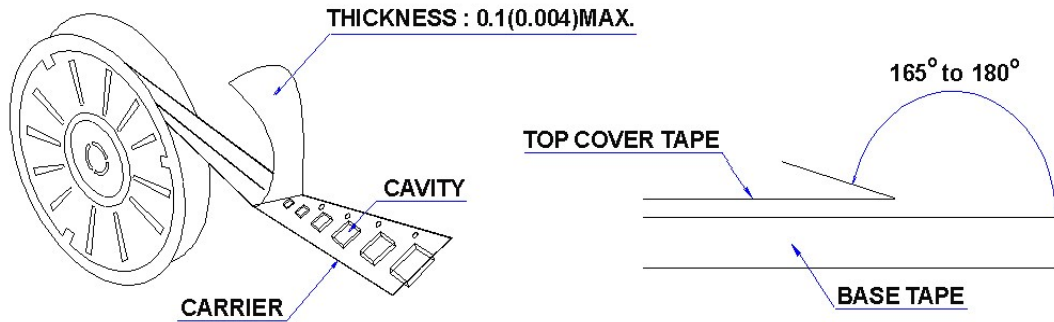

11.2 Packaging Quantity

TYPE	BULK	PCS/REEL
SCD0403	✓	2000
SCD0504	✓	1500
SCD0703	✓	1000
SCD0705	✓	700
SCD1004	✓	700
SCD1005	✓	700

11.3 Reel Dimensions

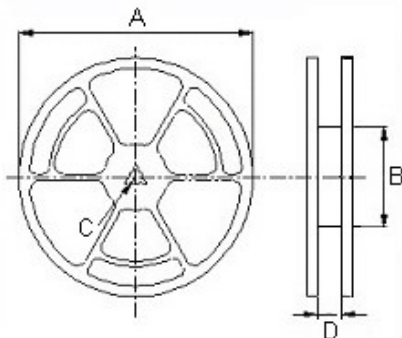

Reel Dimension : m/m

TYPE	A	B	C	D
SCD0403	330	100	13	13.4
SCD0504	330	100	13	17.4
SCD0703	330	100	13	17.4
SCD0705	330	100	13	17.4
SCD1004	330	100	13	24.4
SCD1005	330	100	13	24.4

SCD1005T Series Specification

11 PACKAGING

11.4 Tape Dimensions in mm

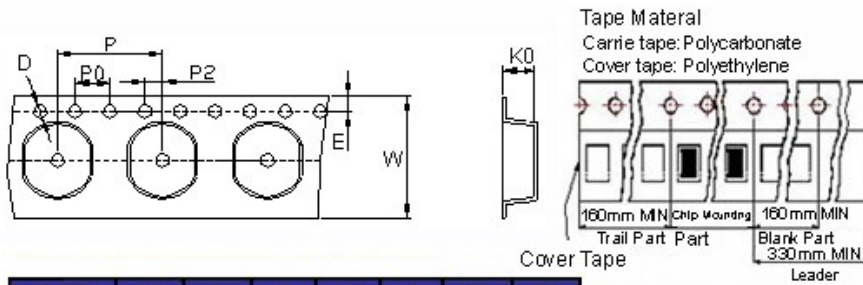

TYPE	K0	D	E	W	P	P0	P2
SCD0403	3.55	1.55	1.75	12	8	4	2
SCD0504	4.80	1.55	1.75	16	8	4	2
SCD0703	3.80	1.55	1.75	16	12	4	2
SCD0705	5.20	1.55	1.75	16	12	4	2
SCD1004	4.50	1.55	1.75	24	12	4	2
SCD1005	5.80	1.55	1.75	24	12	4	2

12 Recommended Pattern

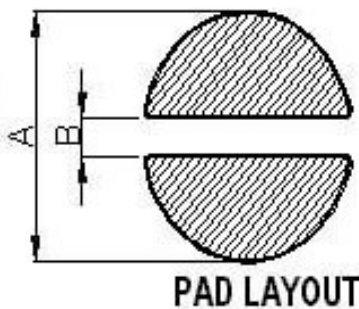

Dimensions in mm

TYPE	A(in/mm)	B(in/mm)
SCD0403	0.22/5.5	0.047/1.2
SCD0504	0.268/6.8	0.051/1.3
SCD0703	0.346/8.8	0.083/2.1
SCD0705	0.346/8.8	0.083/2.1
SCD1004	0.433/11	0.083/2.1
SCD1005	0.433/11	0.083/2.1

13 Note:

1. Please make sure that your product is has been evaluated and confirmed against your specifications when our product is mounted to your product.
2. Do not knock nor drop.
3. All the items and parameters in this product specification have been prescribed on the premise that our product is used for the purpose, under the condition and in the environment agreed upon between you and us. You are requested not to use our product deviating from such agreement.
4. Please keep the distance between transformer/coil and other components (refer to the standard IEC 950)