

TOSHIBA BIPOLAR LINEAR INTEGRATED CIRCUIT SILICON MONOLITHIC

TA8435H/HQ

PWM CHOPPER-TYPE BIPOLAR STEPPING MOTOR DRIVER.

The TA8435H/HQ is a PWM chopper-type sinusoidal micro-step bipolar stepping motor driver.

Sinusoidal micro-step operation is achieved using only a clock signal input by means of built-in hardware.

FEATURES

- Single-chip bipolar sinusoidal micro-step stepping motor driver
- Output current up to 1.5 A (AVE.) and 2.5 A (PEAK)
- PWM chopper-type
- Structured by high voltage Bi-CMOS process technology
- Forward and reverse rotation are available
- 2-, 1-2-, W1-2-, and 2W1-2-phase modes, and one- or two-clock drives can be selected.
- Package: HZIP25-P
- Input pull-up resistor equipped with $\overline{\text{RESET}}$ pin: $R = 100 \text{ k}\Omega$ (typ.)
- Output monitor available with MO I_O ($\overline{\text{MO}}$) = $\pm 2 \text{ mA}$ (MAX.)
- Equipped with $\overline{\text{RESET}}$ and $\overline{\text{ENABLE}}$ pins.

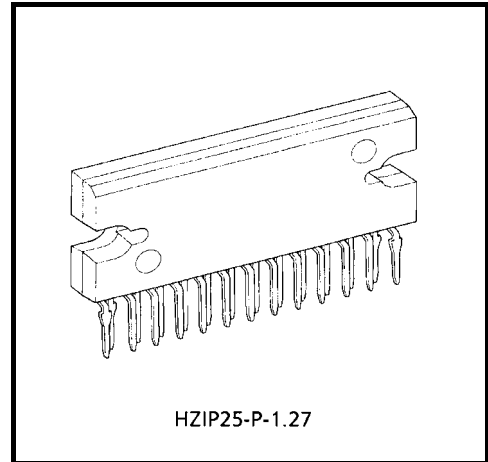

Weight: 9.86 g (typ.)

TA8435HQ:

The TA8435HQ is a Sn-Ag plated product that includes Pb.

The following conditions apply to solderability:

*Solderability

1. Use of Sn-37 Pb solder bath
 - *solder bath temperature = 230°C
 - *dipping time = 5 seconds
 - *number of times = once
 - *use of R-type flux
2. Use of Sn-3.0Ag-0.5Cu solder bath
 - *solder bath temperature = 245°C
 - *dipping time = 5 seconds
 - *number of times = once
 - *use of R-type flux

BLOCK DIAGRAM

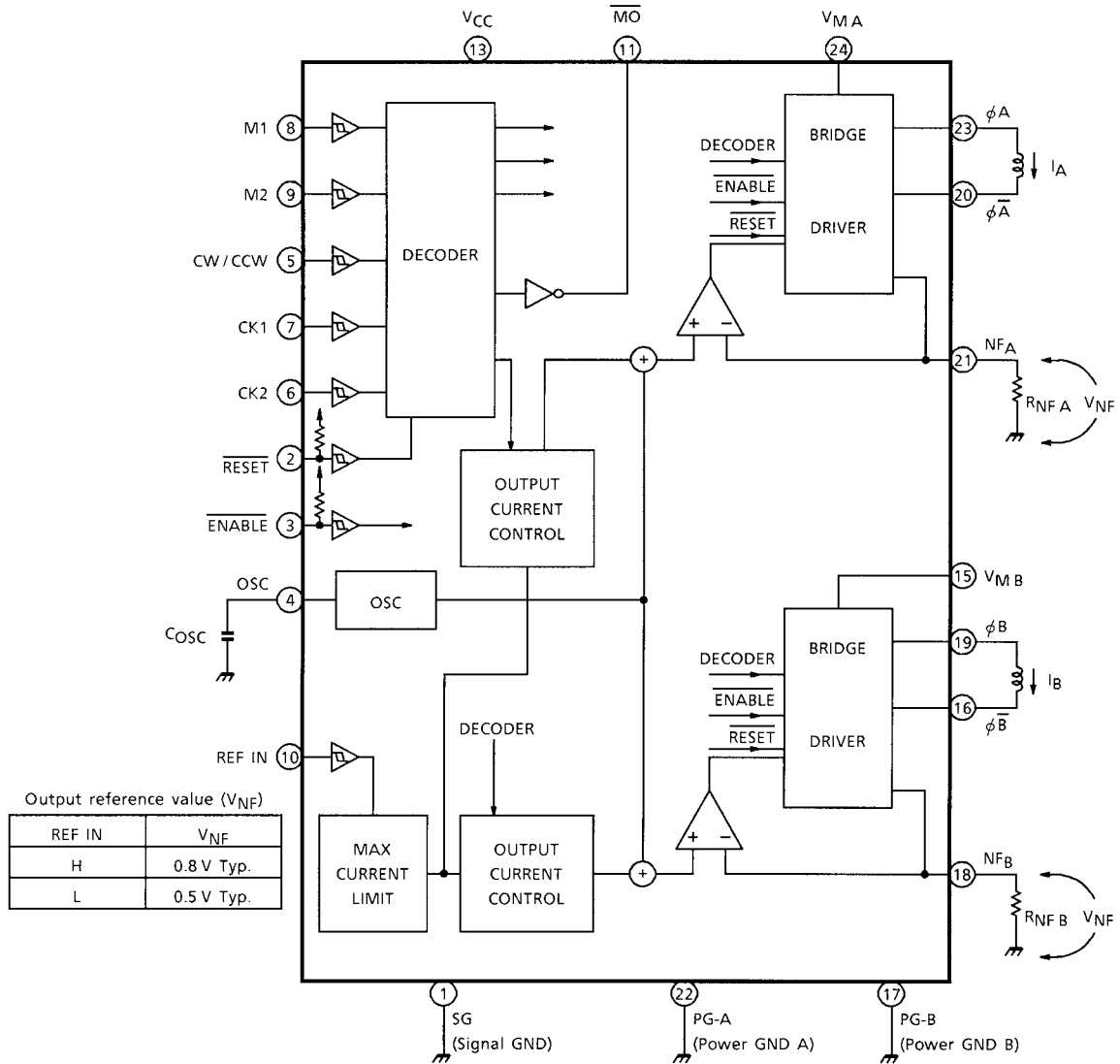

Pull-up resistance : 100 kΩ (Typ.)

Pin 12、14、25 : Non-connection

PIN CONNECTION (top view)

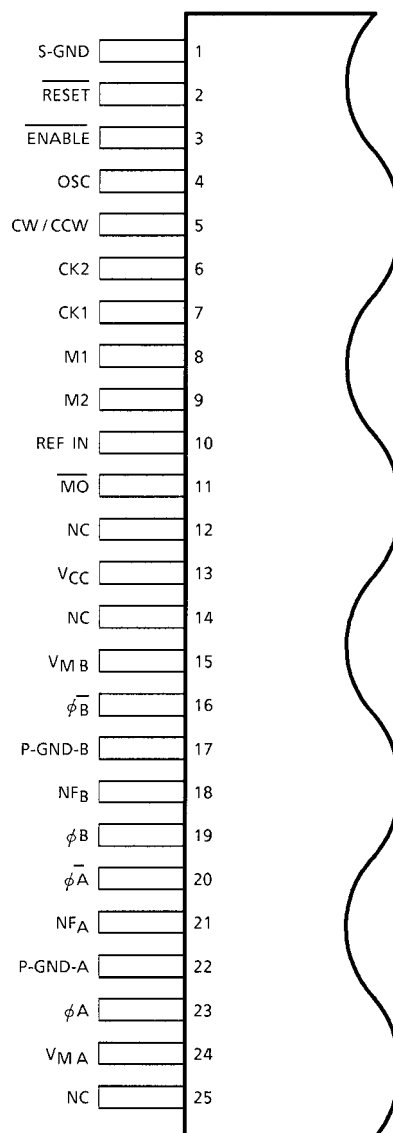

Note: NC: No connection

PIN FUNCTION

PIN No	SYMBOL	FUNCTIONAL DESCRIPTION
1	SG	Signal GND
2	$\overline{\text{RESET}}$	L : RESET
3	$\overline{\text{ENABLE}}$	L : ENABLE, H: OFF
4	OSC	Chopping oscillation is determined by the external capacitor
5	CW / CCW	Forward / Reverse switching terminal.
6	CK2	Clock input terminal.
7	CK1	Clock input terminal.
8	M1	Excitation control input
9	M2	Excitation control input
10	REF IN	V_{NF} control input
11	$\overline{\text{MO}}$	Monitor output
12	NC	No connection.
13	V_{CC}	Voltage supply for logic.
14	NC	No connection.
15	V_{MB}	Output power supply terminal.
16	$\phi \overline{\text{B}}$	Output $\phi \overline{\text{B}}$
17	PG-B	Power GND.
18	NF_{B}	B-ch output current detection terminal.
19	ϕB	Output ϕB
20	$\phi \overline{\text{A}}$	Output $\phi \overline{\text{A}}$
21	NF_{A}	A-ch output current detection terminal.
22	PG-A	Power GND
23	ϕA	Output ϕA
24	V_{MA}	Output power supply terminal.
25	NC	No connection

OUTPUT CIRCUIT

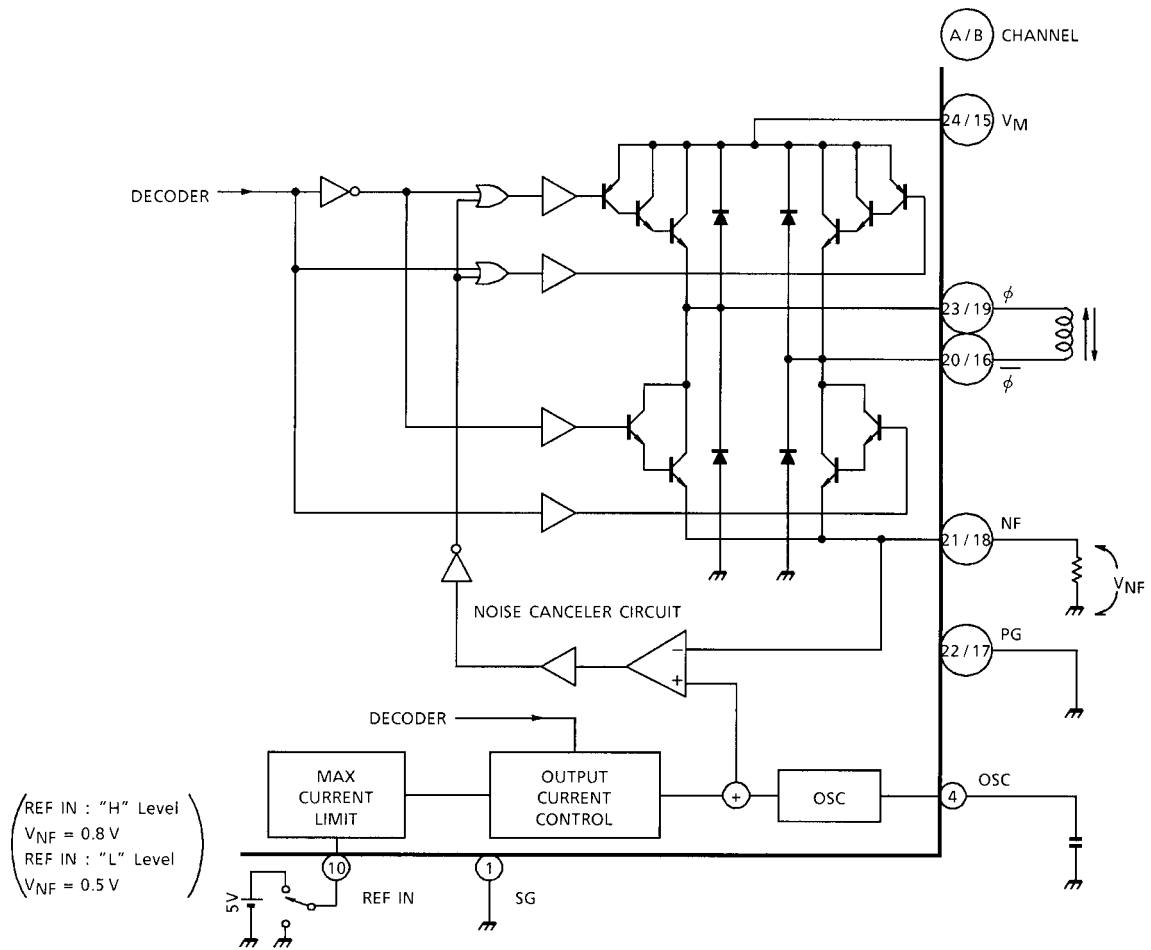

INPUT CIRCUIT

- CK1, CK2, CW / CCW, M1, M2, REF IN: Terminals
- $\overline{\text{RESET}}$, $\overline{\text{ENABLE}}$: Terminals
- OSC: Terminal

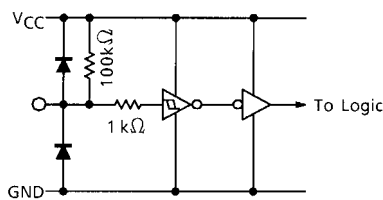
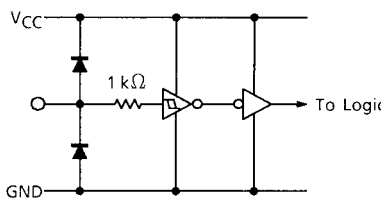

Equipped with 100 kΩ of pull-up resistance.

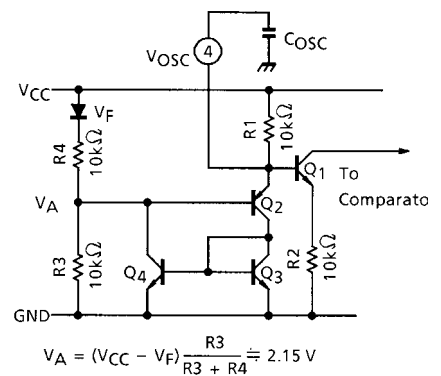

OSCILLATOR FREQUENCY CALCULATION

The sawtooth oscillator (OSC) circuit consists of Q₁ through Q₄ and R₁ through R₄. Q₂ is turned off when V_{OSC} is less than the voltage of 2.5 V + V_{BE} (Q₂), a value that is approximately equal to 2.85 V. V_{OSC} is increased by C_{OSC} charging through R₁. Q₃ and Q₄ are turned on when V_{OSC} becomes 2.85 V (High level.) The Low level of V (4) pin is equal to V_{BE}(Q₂) + V_(SAT)(Q₄), which is approximately equal to 1.4 V. V_{OSC} is calculated by following equation:

$$V_{OSC} = 5 \cdot \left[1 - \exp\left(-\frac{1}{C_{OSC} \cdot R_1}\right) \right] \dots\dots\dots (1).$$

Assuming that V_{OSC} = 1.4 V (t = t₁) and = 2.85 V (t = t₂), and given that C_{OSC} is the external capacitance connected to pin (4) and R₁ is an on-chip 10 kΩ resistor, the OSC frequency is calculated as follows:

$$t_1 = -C_{OSC} \cdot R_1 \cdot \ln \left(1 - \frac{1.4}{5} \right) \dots\dots\dots (2),$$

$$t_2 = -C_{OSC} \cdot R_1 \cdot \ln \left(1 - \frac{2.85}{5} \right) \dots\dots\dots (3),$$

$$f_{OSC} = \frac{1}{t_2 - t_1} = \frac{1}{C_{OSC} \left(R_1 \cdot \ln \left(1 - \frac{1.4}{5} \right) - R_1 \cdot \ln \left(1 - \frac{2.85}{5} \right) \right)}$$

$$= \frac{1}{5.15 \cdot C_{OSC}} \text{ (kHz) (C}_{OSC} : \mu\text{F) .}$$

ENABLE AND RESET FUNCTION AND \overline{MO} SIGNAL

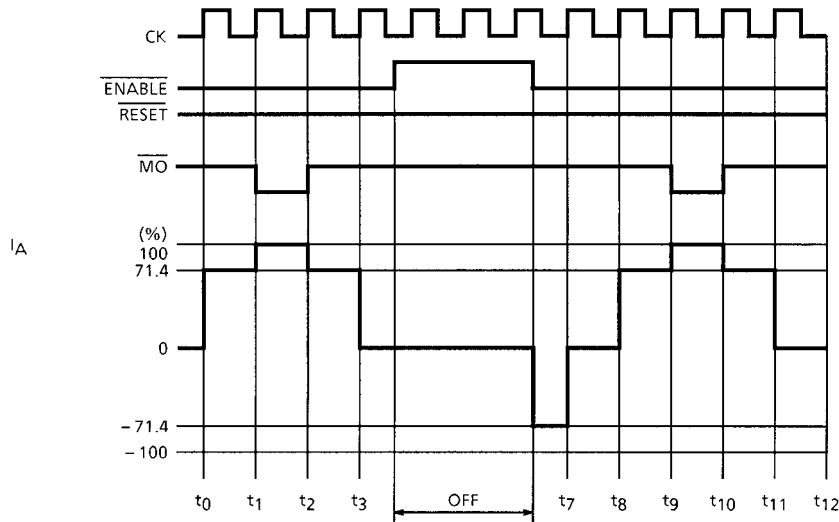

Figure 1: 1-2 phase drive mode (M1: H, M2: L)

The \overline{ENABLE} signal at High level disables only the output signals. Internal logic functions proceed in accordance with input clock signals and without regard to the \overline{ENABLE} signal. Therefore output current is initiated by the timing of the internal logic circuit after release of disable mode. Figure 1 shows the \overline{ENABLE} functions for when 1-2 phase drive is selected for the system.

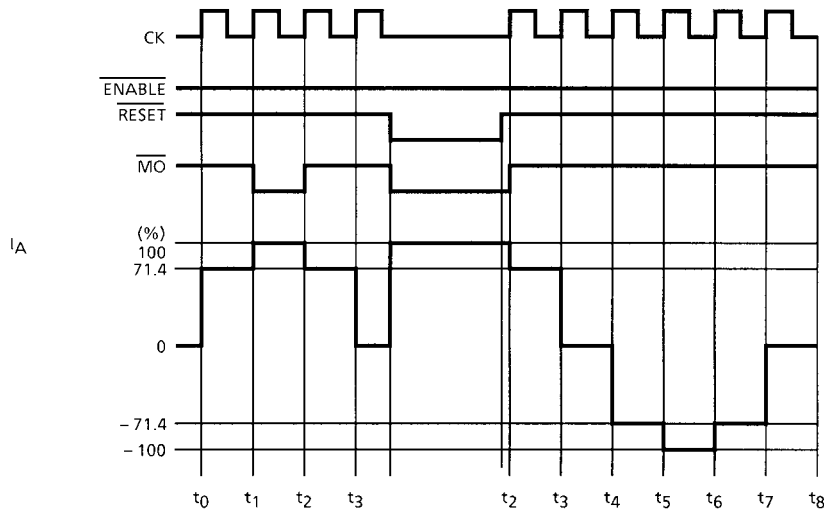

Figure 2: 1-2 phase drive mode (M1: H, M2: L)

The \overline{RESET} signal at Low level not only turns off the output signals but also stops the internal clock functions, while \overline{MO} (Monitor Output) signals are set to low. Output signals are initiated from the initial point after release of \overline{RESET} (High), as shown in Figure 2. \overline{MO} signals can be used as rotation and initial signals for stable rotation checking.

FUNCTION

INPUT					MODE
CK1	CK2	CW / CCW	RESET	ENABLE	
	H	L	H	L	CW
	L	L	H	L	INHIBIT (Note)
H		L	H	L	CCW
L		L	H	L	INHIBIT (Note)
	H	H	H	L	CCW
	L	H	H	L	INHIBIT (Note)
H		H	H	L	CW
L		H	H	L	INHIBIT (Note)
X	X	X	L	L	RESET
X	X	X	X	H	Z

INITIAL MODE

EXCITATION MODE	A PHASE CURRENT	B PHASE CURRENT
2-Phase	100%	-100%
1-2-Phase	100%	0%
W1-2-Phase	100%	0%
2W1-2-Phase	100%	0%

Z: High Impedance

X: Don't Care

INPUT		MODE (EXCITATION)
M1	M2	
L	L	2-Phase
H	L	1-2-Phase
L	H	W1-2-Phase
H	H	2W1-2-Phase

2-PHASE EXCITATION (M1: L, M2: L, CW MODE)

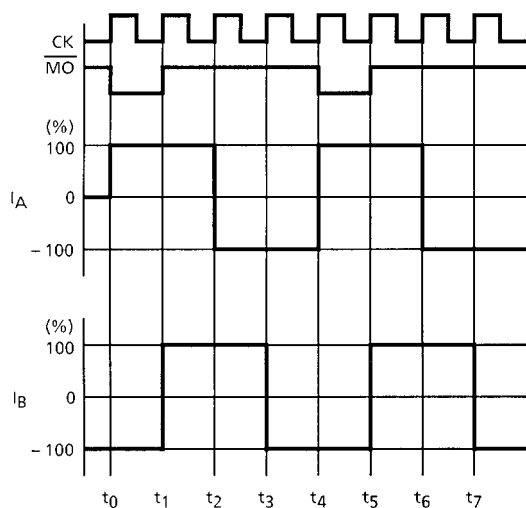

1-2-PHASE EXCITATION (M1: H, M2: L, CW MODE)

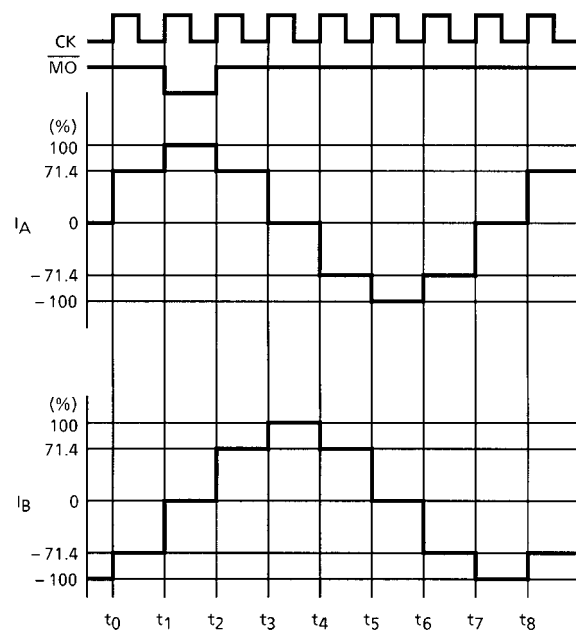

W1-2-PHASE EXCITATION (M1: L, M2: H, CW MODE)

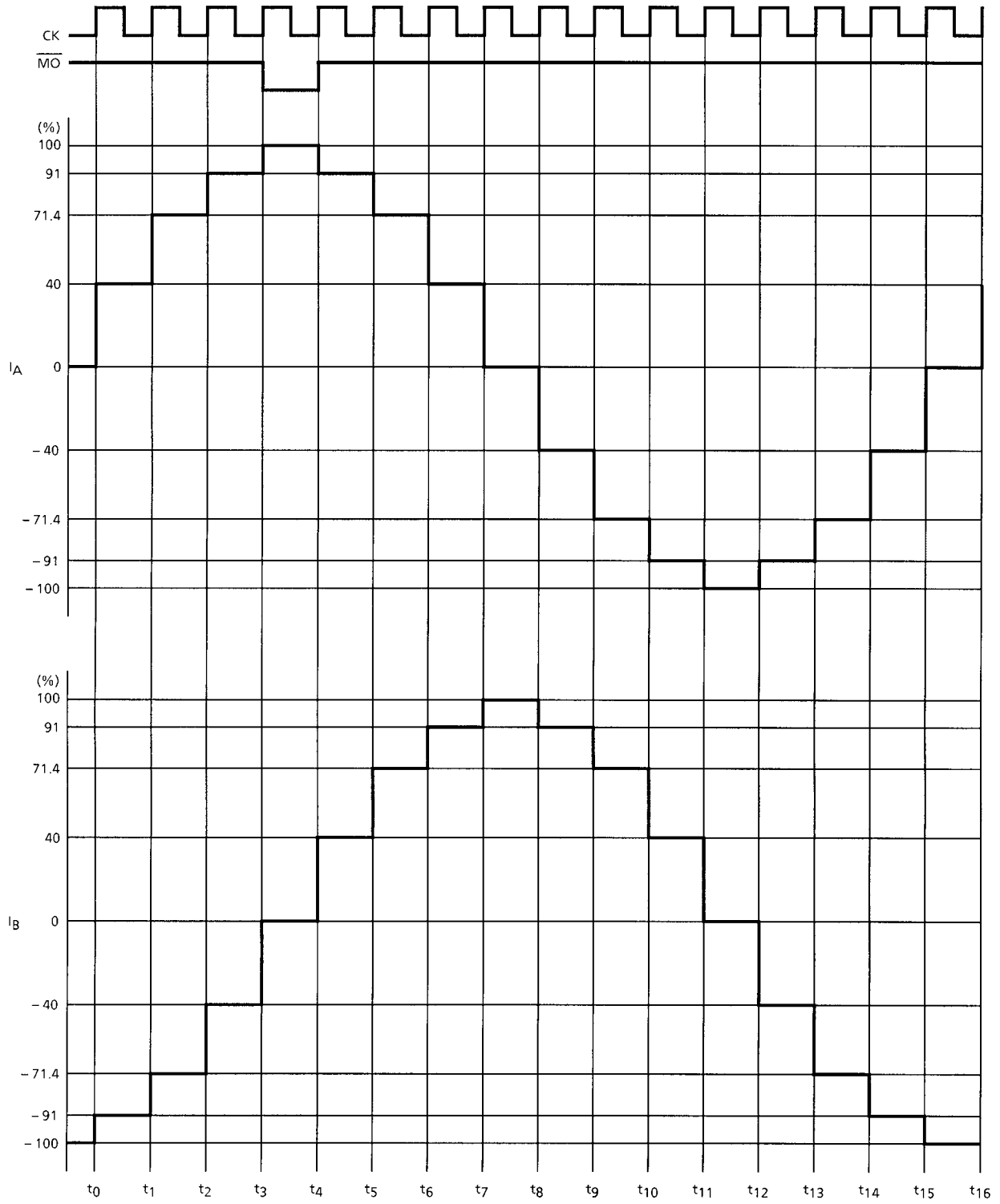

2W1-2-PHASE EXCITATION (M1: H, M2: H, CW MODE)

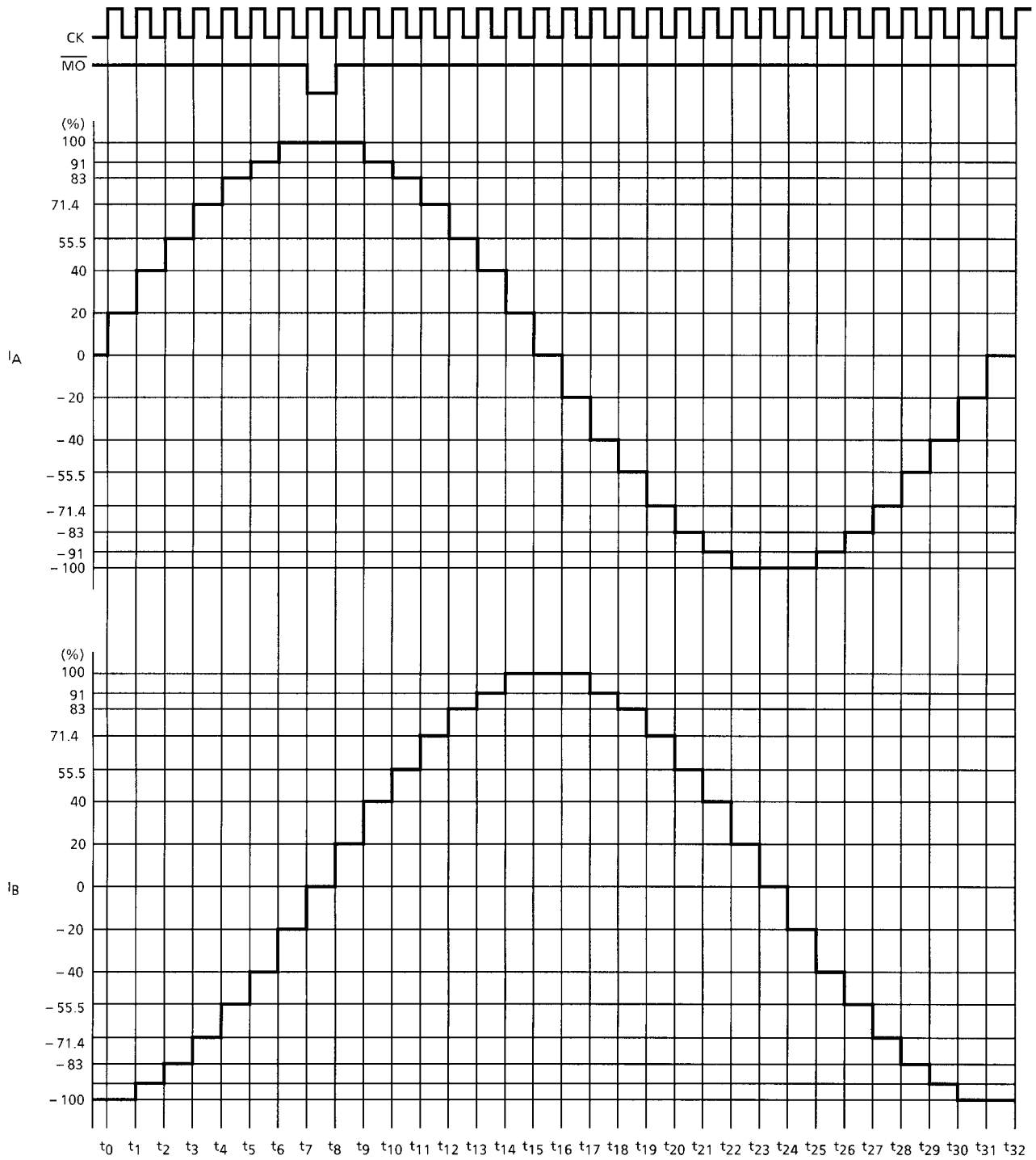

ABSOLUTE MAXIMUM RATINGS (Ta = 25°C)

CHARACTERISTIC		SYMBOL	RATING	UNIT
Supply Voltage		V _{CC}	5.5	V
Output Voltage		V _M	40	V
Output Current	PEAK	I _{O (PEAK)}	2.5	A
	AVE	I _{O (AVE.)}	1.5	
\overline{MO} Output Current		I _{O (\overline{MO})}	±2	mA
Input Voltage		V _{IN}	~V _{CC}	V
Power Dissipation		P _D	5 (Note 1)	W
			43 (Note 2)	
Operating Temperature		T _{opr}	-40~85	°C
Storage Temperature		T _{stg}	-55~150	°C
Feed Back Voltage		V _{NF}	1.0	V

Note 1: No heat sink

Note 2: T_c = 85°C

RECOMMENDED OPERATING CONDITIONS (Ta = -20~75°C)

CHARACTERISTIC	SYMBOL	TEST CONDITION	MIN	TYP.	MAX	UNIT
Supply Voltage	V _{CC}	—	4.5	5.0	5.5	V
Output Voltage	V _M	—	21.6	24	26.4	V
Output Current	I _{OUT}	—	—	—	1.5	A
Input Voltage	V _{IN}	—	—	—	V _{CC}	V
Clock Frequency	f _{CK}	—	—	—	5	kHz
OSC Frequency	f _{OSC}	—	15	—	80	kHz

ELECTRICAL CHARACTERISTICS (Ta = 25°C, VCC = 5 V, VM = 24 V)

CHARACTERISTIC		SYMBOL	TEST CIR-CUIT	TEST CONDITION	MIN	TYP.	MAX	UNIT	
Input Voltage	High	$V_{IN(H)}$	1	M1, M2, CW / CCW, REF IN \overline{ENABLE} , CK1, CK2 RESET	3.5	—	$V_{CC} + 0.4$	V	
	Low	$V_{IN(L)}$			GND - 0.4	—	1.5		
Input Hysteresis Voltage		V_H			—	600	—	mV	
Input Current		$I_{IN-1(H)}$	1	M1, M2, REF IN, $V_{IN} = 5.0$ V	—	—	100	nA	
		$I_{IN-1(L)}$		\overline{RESET} , \overline{ENABLE} , $V_{IN} = 0$ V INTERNAL PULL-UP RESISTOR	10	50	100	μ A	
		$I_{IN-2(L)}$		SOURCE TYPE, $V_{IN} = 0$ V	—	—	100	nA	
Quiescent Current VCC Terminal		I_{CC1}	1	Output Open, $\overline{RESET} : H$ $\overline{ENABLE} : L$ (2, 1-2 phase excitation)	—	10	18	mA	
		I_{CC2}		Output Open, $\overline{RESET} : H$ $\overline{ENABLE} : L$ (W1-2, 2W1-2 phase excitation)	—	10	18		
		I_{CC3}		$\overline{RESET} : L$, $\overline{ENABLE} : H$	—	5	—		
		I_{CC4}		$\overline{RESET} : H$, $\overline{ENABLE} : H$	—	5	—		
Comparator Reference Voltage	High	$V_{NF(H)}$	3	REF IN H Output Open	(Note)	0.72	0.8	0.88	V
	Low	$V_{NF(L)}$		REF IN L Output Open		0.45	0.5	0.55	
Output Differential		ΔV_O	—	B / A, $C_{OSC} = 0.0033 \mu F$, $R_{NF} = 0.8 \Omega$	-10	—	10	%	
$V_{NF(H)} - V_{NF(L)}$		ΔV_{NF}	—	$V_{NF(L)} / V_{NF(H)}$ $C_{OSC} = 0.0033 \mu F$, $R_{NF} = 0.8 \Omega$	56	63	70	%	
NF Terminal Current		I_{NF}	—	SOURCE TYPE	—	170	—	μ A	
Maximum OSC Frequency		$f_{OSC(MAX.)}$	—	—	100	—	—	kHz	
Minimum OSC Frequency		$f_{OSC(MIN.)}$	—	—	—	—	10	kHz	
OSC Frequency		f_{OSC}	—	$C_{OSC} = 0.0033 \mu F$	25	44	62	kHz	
Minimum Clock Pulse Width		$t_W(CK)$	—	—	—	1.0	—	μs	
Output Voltage		$V_{OH(MO)}$	—	$I_{OH} = -40 \mu A$	4.5	4.9	V_{CC}	V	
		$V_{OL(MO)}$		$I_{OL} = 40 \mu A$	GND	0.1	0.5		

Note: 2-phase excitation, $R_{NF} = 0.7 \Omega$, $C_{OSC} = 0.0033 \mu F$

OUTPUT BLOCK

CHARACTERISTIC				SYMBOL	TEST CIR-CUIT	TEST CONDITION	MIN	TYP.	MAX	UNIT		
Output Saturation Voltage	Upper Side			$V_{SAT U1}$	4	$I_{OUT} = 1.5 A$	—	2.1	2.8	V		
	Lower Side			$V_{SAT L1}$			—	1.3	2.0			
	Upper Side			$V_{SAT U2}$		$I_{OUT} = 0.8 A$	—	1.8	2.2			
	Lower Side			$V_{SAT L2}$			—	1.1	1.5			
	Upper Side			$V_{SAT U3}$		$I_{OUT} = 2.5 A$ Pulse width 30 ms	—	2.5	3.0			
	Lower Side			$V_{SAT L3}$			—	1.8	2.2			
Diode Forward Voltage	Upper Side			$V_F U1$	5	$I_{OUT} = 1.5 A$	—	2.0	3.0	V		
	Lower Side			$V_F L1$			—	1.5	2.1			
	Upper Side			$V_F U2$		$I_{OUT} = 2.5 A$ Pulse width 30 ms	—	2.5	3.3			
	Lower Side			$V_F L2$			—	1.8	2.5			
Output Dark Current (A + B Channels)				I_{M1}	2	ENABLE : "H" Level, Output Open RESET : "L" Level	—	—	50	μA		
				I_{M2}		ENABLE : "L" Level Output Open RESET : "H" Level	—	8	15	mA		
A-B Chopping Current (Note)	2W1-2 ϕ	W1-2 ϕ	1-2 ϕ	VECTOR	—	$\theta = 0$	REF IN : H $R_{NF} = 0.8 \Omega$ $C_{OSC} = 0.0033 \mu F$	—	100	—	%	
	2W1-2 ϕ	—	—			$\theta = 1 / 8$		—	100	—		
	2W1-2 ϕ	W1-2 ϕ	—			$\theta = 2 / 8$		86	91	96		
	2W1-2 ϕ	—	—			$\theta = 3 / 8$		78	83	88		
	2W1-2 ϕ	W1-2 ϕ	1-2 ϕ			$\theta = 4 / 8$		66.4	71.4	76.4		
	2W1-2 ϕ	—	—			$\theta = 5 / 8$		50.5	55.5	60.5		
	2W1-2 ϕ	W1-2 ϕ	—			$\theta = 6 / 8$		35	40	45		
	2W1-2 ϕ	—	—			$\theta = 7 / 8$		15	20	25		
	2 Phase Excitation Mode VECTOR					—		—	—	100		—

Note: Maximum current ($\theta = 0$): 100%
 2W1-2 ϕ : 2W1-2-phase excitation mode
 W1-2 ϕ : W1-2-phase excitation mode
 1-2 ϕ : 1-2-phase excitation mode

CHARACTERISTIC			SYMBOL	TEST CIR-CUIT	TEST CONDITION	MIN	TYP.	MAX	UNIT				
A-B Chopping Current (Note)	2W1-2φ	W1-2φ	1-2φ	VECTOR	—	REF IN : H R _{NF} = 0.8 Ω C _{OSC} = 0.0033 μF			%				
	2W1-2φ	—	—							θ = 0	—	100	—
	2W1-2φ	—	—							θ = 1 / 8	—	100	—
	2W1-2φ	W1-2φ	—							θ = 2 / 8	86	91	96
	2W1-2φ	—	—							θ = 3 / 8	78	83	88
	2W1-2φ	W1-2φ	1-2φ							θ = 4 / 8	66.4	71.4	76.4
	2W1-2φ	—	—							θ = 5 / 8	50.5	55.5	60.5
	2W1-2φ	W1-2φ	—							θ = 6 / 8	35	40	45
	2W1-2φ	—	—							θ = 7 / 8	15	20	25
2 Phase Excitation Mode VECTOR					—	100	—						
Feed Back Voltage Step			ΔV _{NF}	—	Δθ = 0 / 8 - 1 / 8	REF IN : H R _{NF} = 0.8 Ω C _{OSC} = 0.0033 μF			mV				
					Δθ = 1 / 8 - 2 / 8					—	0	—	
					Δθ = 2 / 8 - 3 / 8					32	72	112	
					Δθ = 3 / 8 - 4 / 8					24	64	104	
					Δθ = 4 / 8 - 5 / 8					53	93	133	
					Δθ = 5 / 8 - 6 / 8					87	127	167	
					Δθ = 6 / 8 - 7 / 8					84	124	164	
Output T _r Switching Characteristics			t _r	7	R _L = 2 Ω, V _{NF} = 0 V, C _L = 15 pF				μs				
										t _f	—	0.3	—
										t _{pLH}	—	2.2	—
										t _{pHL}	—	1.5	—
										t _{pLH}	—	2.7	—
										t _{pHL}	—	5.4	—
										t _{pLH}	—	6.3	—
										t _{pHL}	—	2.0	—
										t _{pHL}	—	2.5	—
t _{pHL}	—	5.0	—										
t _{pHL}	—	6.0	—										
Output Leakage Current	Upper Side	I _{OH}	6	V _M = 30 V					μA				
	Lower Side	I _{OL}								—	—	50	

Note: Maximum current (θ = 0): 100%
 2W1-2φ: 2W1-2-phase excitation mode
 W1-2φ : W1-2-phase excitation mode
 1-2φ : 1-2-phase excitation mode

TEST CIRCUIT 1

V_{IN} (H), (L), I_{IN} (H), (L)

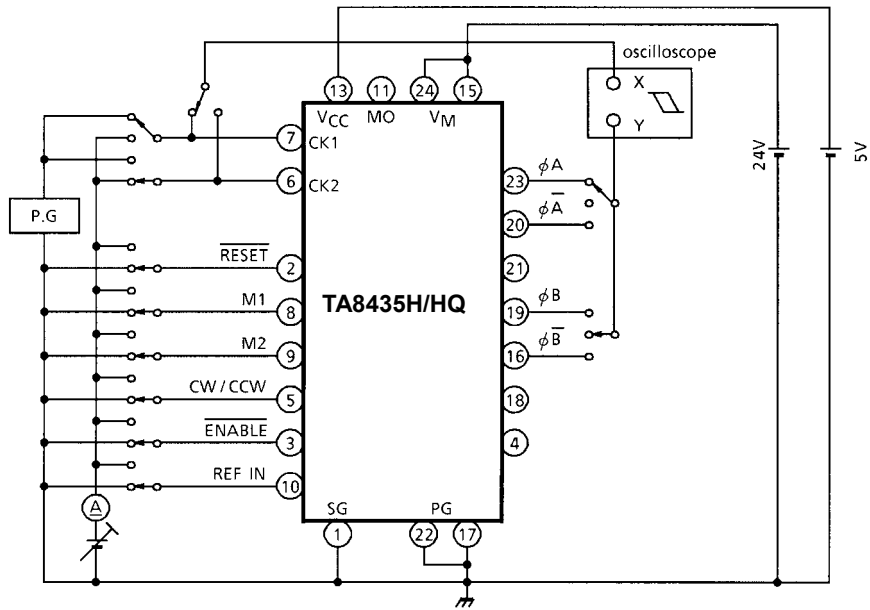

TEST CIRCUIT 2

I_{CC} , I_M

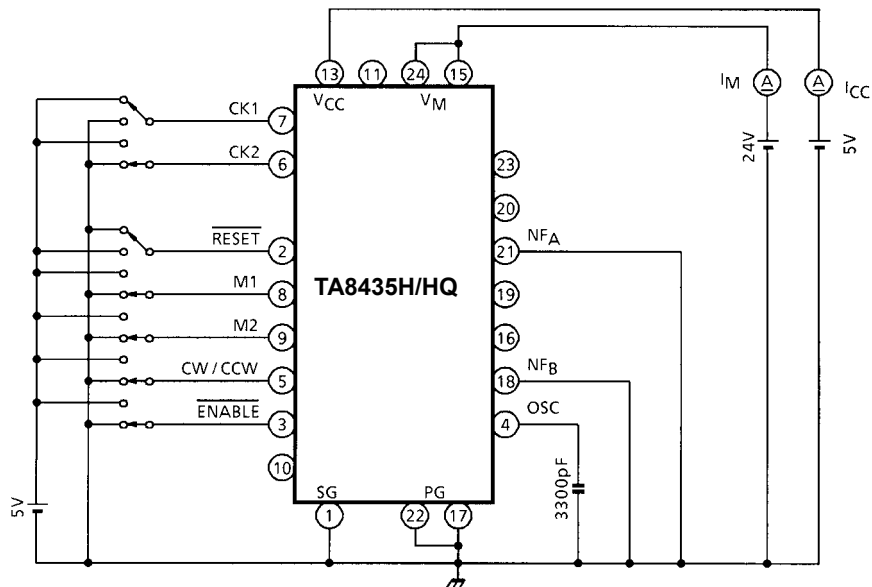

TEST CIRCUIT 3

$V_{NF(H)}, (L)$

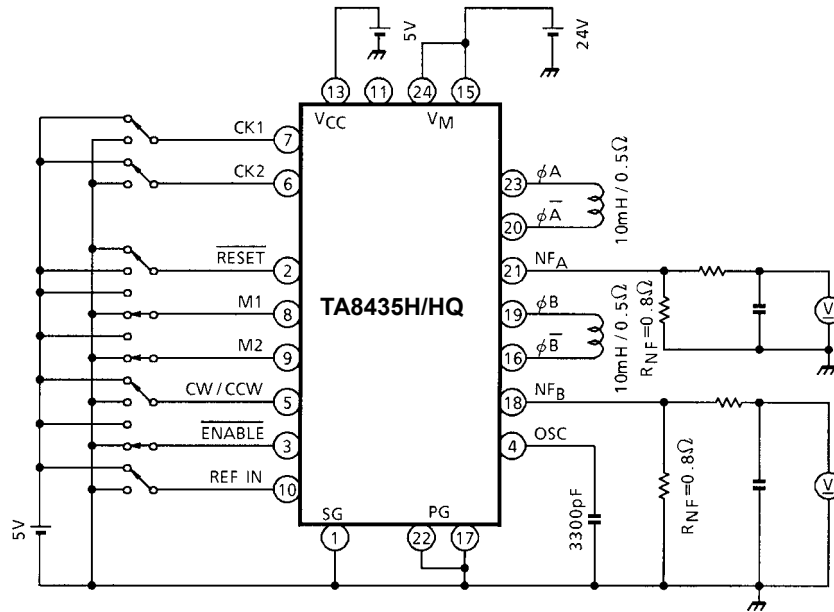

TEST CIRCUIT 4

$V_{CE(SAT)}$ UPPER SIDE, LOWER SIDE

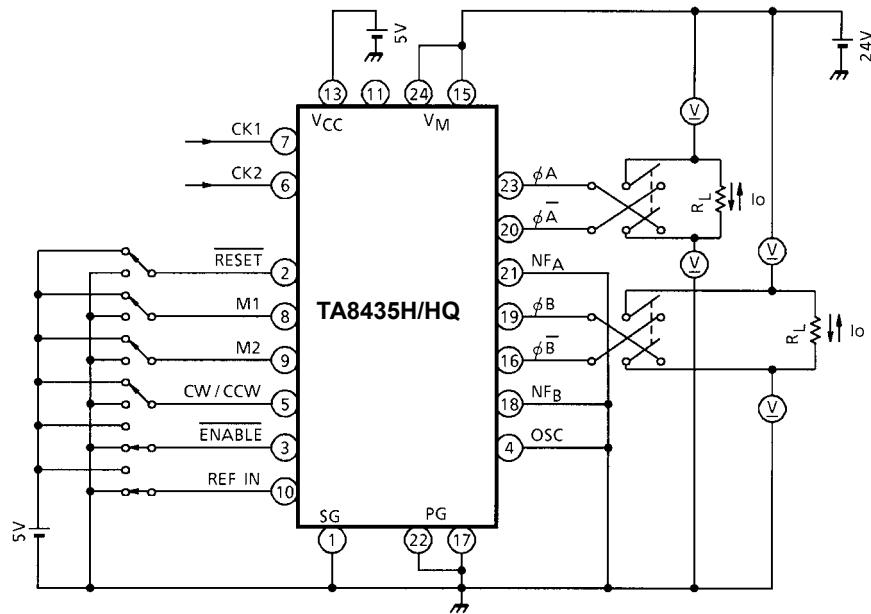

Note: Calibrate I_o to 1.5 A / 0.8 A by R_L

TEST CIRCUIT 5
 V_{FU} , V_{FL}

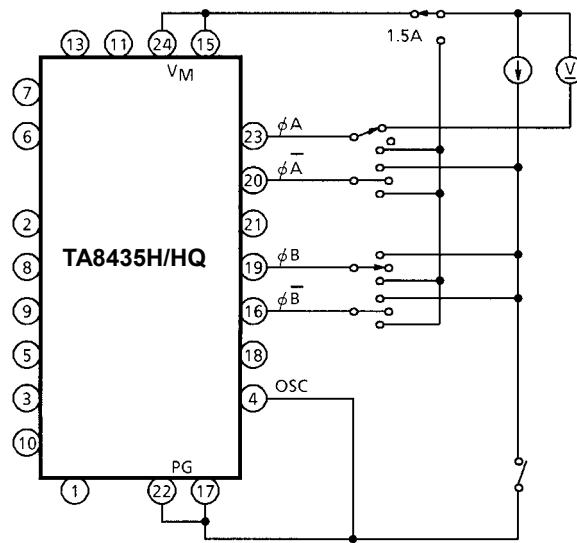

TEST CIRCUIT 6
 I_{OH} , I_{OL}

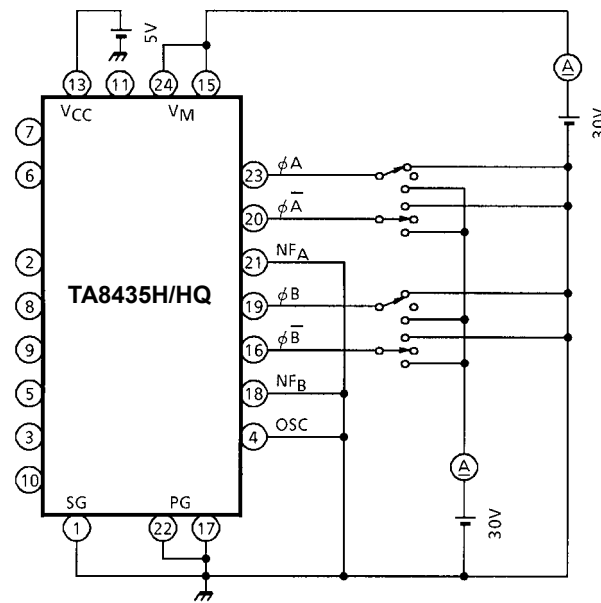

**AC ELECTRICAL CHARACTERISTICS, MEASUREMENT WAVE
CK (OSC)-OUT**

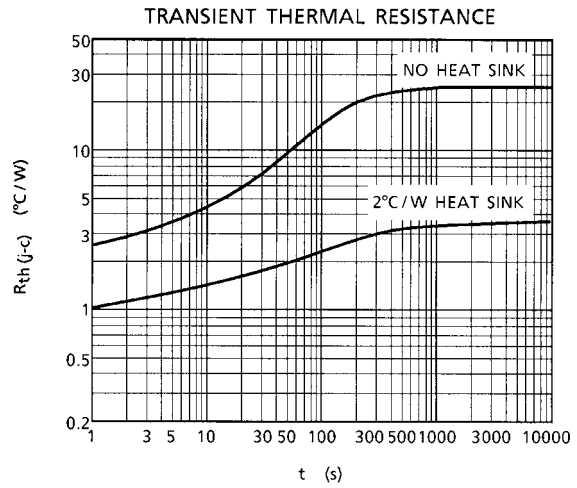
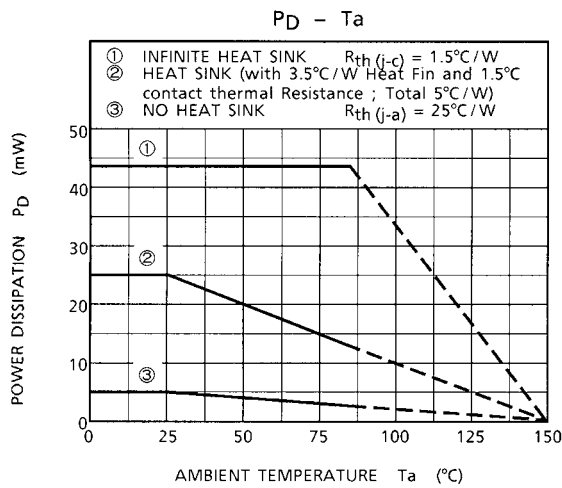
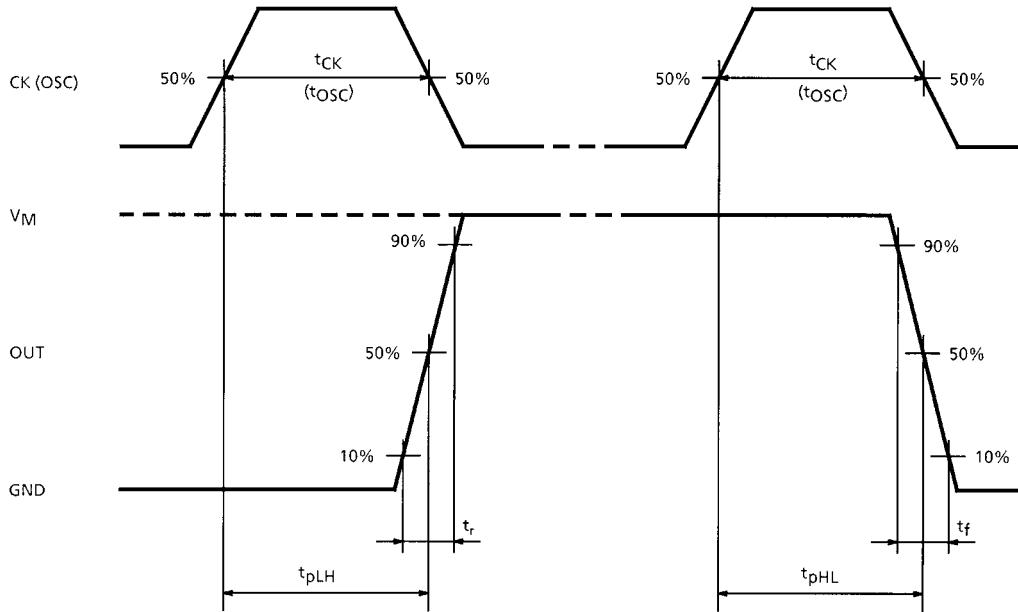

OUTPUT CURRENT VECTOR ORBIT (normalized to 90° per step)

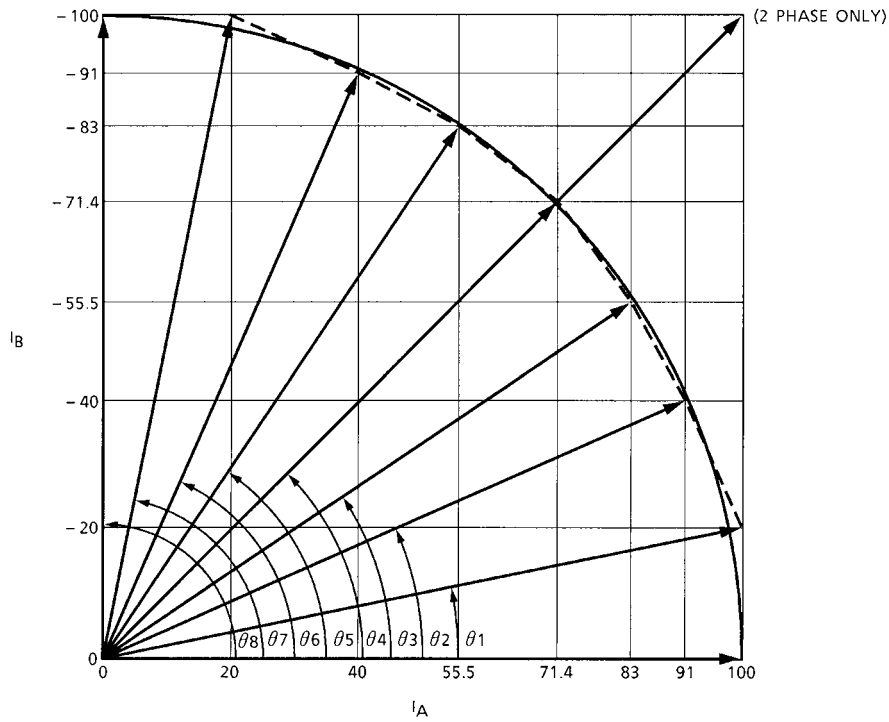

θ	ROTATION ANGLE		VECTOR LENGTH		
	IDEAL	TA8435H/HQ	IDEAL	TA8435H/HQ	
θ0	0°	0°	100	100.00	—
θ1	11.25°	11.31°	100	101.98	—
θ2	22.5°	23.73°	100	99.40	—
θ3	33.75°	33.77°	100	99.85	—
θ4	45°	45°	100	100.97	141.42
θ5	56.25°	56.23°	100	99.85	—
θ6	67.5°	66.27°	100	99.40	—
θ7	78.75°	78.69°	100	101.98	—
θ8	90°	90°	100	100.00	—
				1-2 / W1-2 / 2W1-2-Phase	2-Phase

APPLICATION CIRCUIT

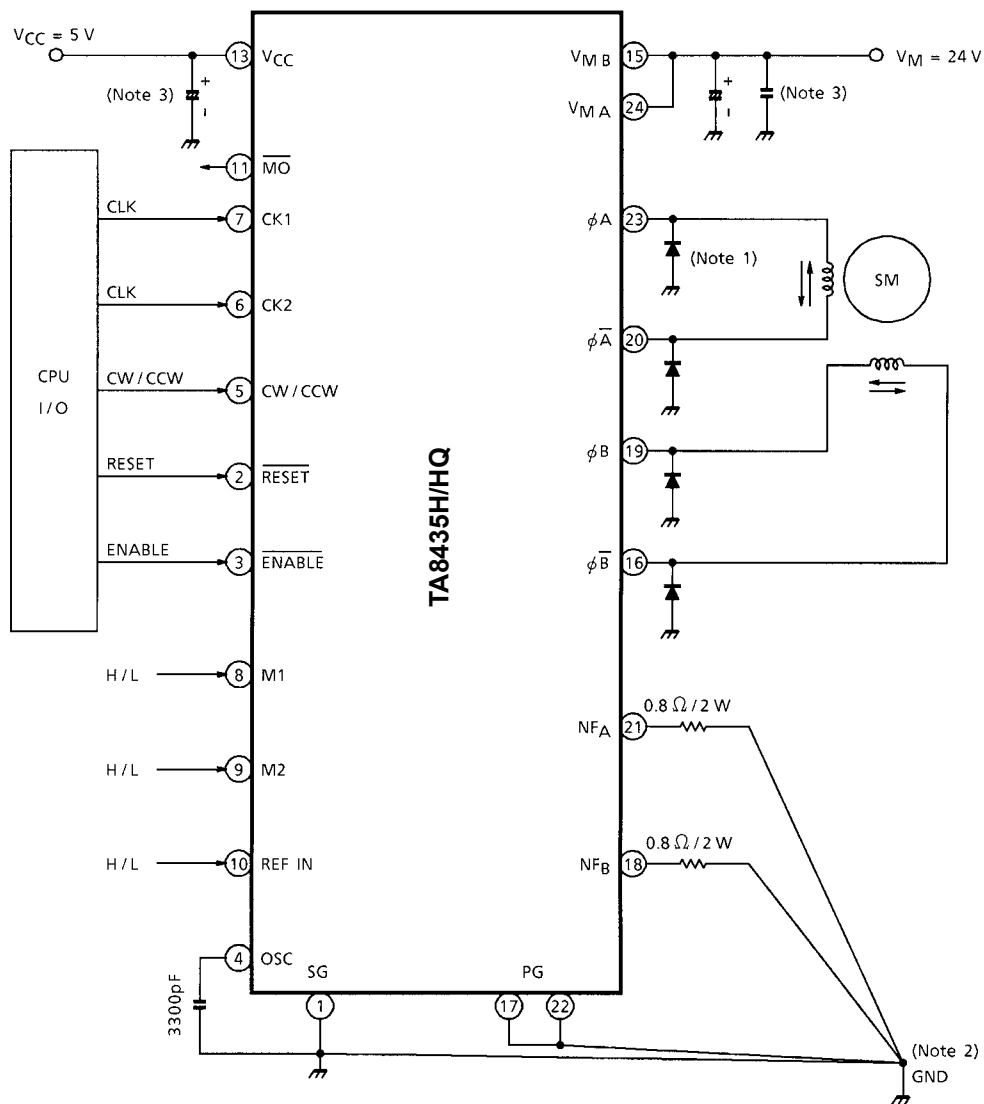

Note 1: A Schottky diode (3GWJ42) for preventing punch-through current should also be connected between each output (pin 16 / 19 / 20 / 23).

Note 2: The GND pattern should be laid out at one point to prevent common impedance.

Note 3: A capacitor for noise suppression should be connected between the power supply (V_{CC} , V_M) and GND to stabilize operation.

Note 4: Utmost care is necessary in the design of the output, V_{CC} , V_M , and GND lines since the IC may be destroyed by short-circuiting between outputs, air contamination faults, or faults due to improper grounding, or by short-circuiting between contiguous pins.

When using TA8435H/HQ

0. Introduction

The TA8435H/HQ controls the PWM to set the stepping motor winding current to a constant current. The device is a micro-step driver IC used to drive the stepping motor efficiently at low vibration.

1. Micro-step drive

The TA8435H/HQ drives the stepping motor in micro steps with a maximum resolution of 1/8 of the 2-phase stepping angle (in 2W1-2-phase mode).

In micro step operation, A-phase and B-phase current levels are set inside the IC so that the composite vector size and the rotation angle are even. Just inputting clock signals rotates the stepping motor in micro steps.

2. PWM control and output current setting

(1) Output current path (PWM control)

The TA8435H/HQ controls the PWM by turning the upper power transistor on and off. Here, current flows as shown in the figure below.

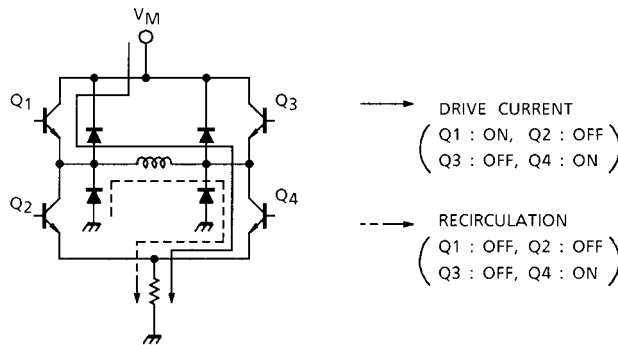

(2) Setting of output current by REF-IN input and current detection resistor

The motor current (maximum current for micro-step drive) I_O is set as shown in the following equation, using REF-IN input and the external current detection resistor RNF.

$$I_O = V_{REF} / R_{NF}$$

where,

$$\text{REF-IN} = \text{High}, \quad V_{REF} = 0.8 \text{ V}$$

$$\text{REF-IN} = \text{Low}, \quad V_{REF} = 0.5 \text{ V}$$

3. Logic control

(1) Clock input for rotation direction control

To switch rotation between forward and reverse, there are two types of clock input: one-clock input and two-clock input.

(a) One-clock input

One clock pin, CK1 or CK2, is used for clock input. In this case, rotation is switched between forward or reverse using a CW or CCW signal.

<Input signal example: 1-2-phase mode>

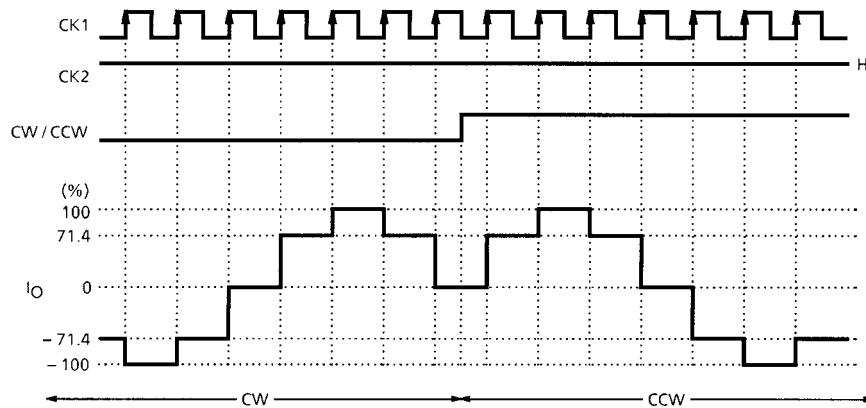

(b) Two-clock input

Both clock pins, CK1 and CK2, are used for clock input. Switching between CK1 and CK2 controls forward and reverse rotation.

<Input signal example: 1-2-phase mode>

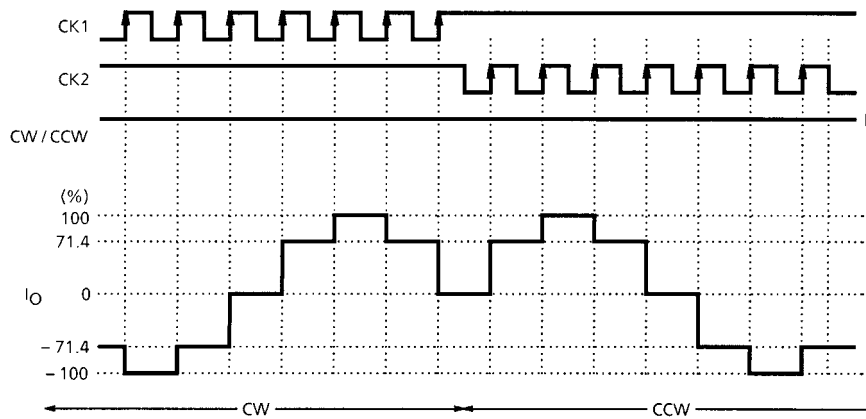

- (2) **Mode setting**
 Setting M1 and M2 selects one of the following modes: 2-phase, 1-2-phase, W1-2-phase, and 2W1-2-phase modes.

- (3) **Monitor (\overline{MO}) output**
 The product supports the use of monitor output to monitor the current waveform location.
 For 2-phase mode, the \overline{MO} output is Low if the timing of the A-phase current = 100% and that of the B-phase current = -100%.
 For 1-2-phase, W1-2-phase, or 2W1-2-phase mode, the \overline{MO} output is Low if the timing of the A-phase current = 100% and that of the B-phase current = 0%.

- (4) **Reset pin**
 The product supports the use of reset input to reset the internal counter.
 Setting \overline{RESET} to Low resets the internal counter, forcing the output current to the same value as that when the \overline{MO} output is Low.

- (5) **Phase mode switching**
 To avoid step changing during motor rotation, the current must not fluctuate at phase mode switching. Pay attention to the following points.
 - (a) During switching between 2-phase and other phase modes, the current fluctuates.
 - (b) When switching between phase modes other than 2-phase, the current can be switched without fluctuation if the timing of \overline{MO} output = Low.
 However, when switching as follows, set \overline{RESET} to Low beforehand:
 from 1-2-phase to W1-2-phase or 2W1-2-phase mode;
 from W1-2-phase to 2W1-2-phase mode.

<Example of Input Signal>

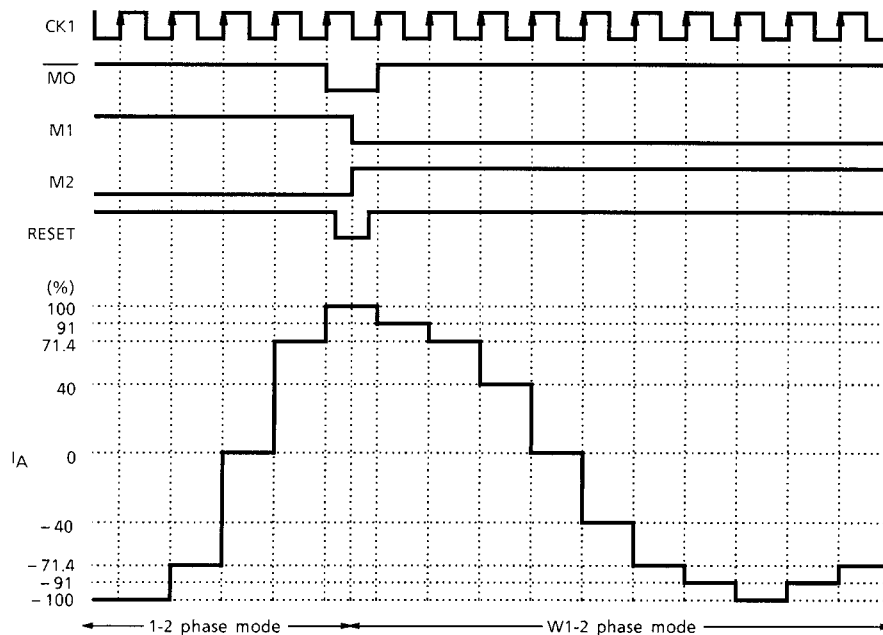

4. PWM oscillation frequency (external capacitor setting)

An external capacitor connected to the OSC pin is used to generate internally a sawtooth waveform. PWM is controlled using this frequency.

Toshiba recommend 3300 pF for the capacitance, taking variations between ICs into consideration.

5. External Schottky diode

A parasitic diode can be supported on the lower side of the output. When PWM is controlled, current flows to this parasitic diode. Unfortunately, this current has the effect of generating punch-through current and micro-step waveform fluctuation. For this reason, be sure to connect a Schottky barrier diode externally.

This external diode can also reduce heat generated in the IC.

6. Power dissipation

The IC power dissipation is determined by the following equation (where the Schottky diode is connected between the output pin and GND):

$$P = V_{CC} \times I_{CC} + V_M \times I_M + I_O (t_{ON} \times V_{SAT-U} + V_{SAT-L})$$

$$t_{ON} = T_{ON} / T_S \text{ (PWM control ON duty).}$$

The higher the ambient temperature, the smaller the power dissipation.

Check the P_D - T_a curve, and be sure to design the heat dissipation with a sufficient margin.

7. Heatsink fin processing

The IC fin (rear) is electrically connected to the rear of the chip.

When current flows to the fin, the IC malfunctions.

If there is any possibility of a voltage being generated between the IC GND and the fin, either ground the fin or insulate it.

PACKAGE DIMENSIONS

HZIP25-P-1.27

Unit: mm

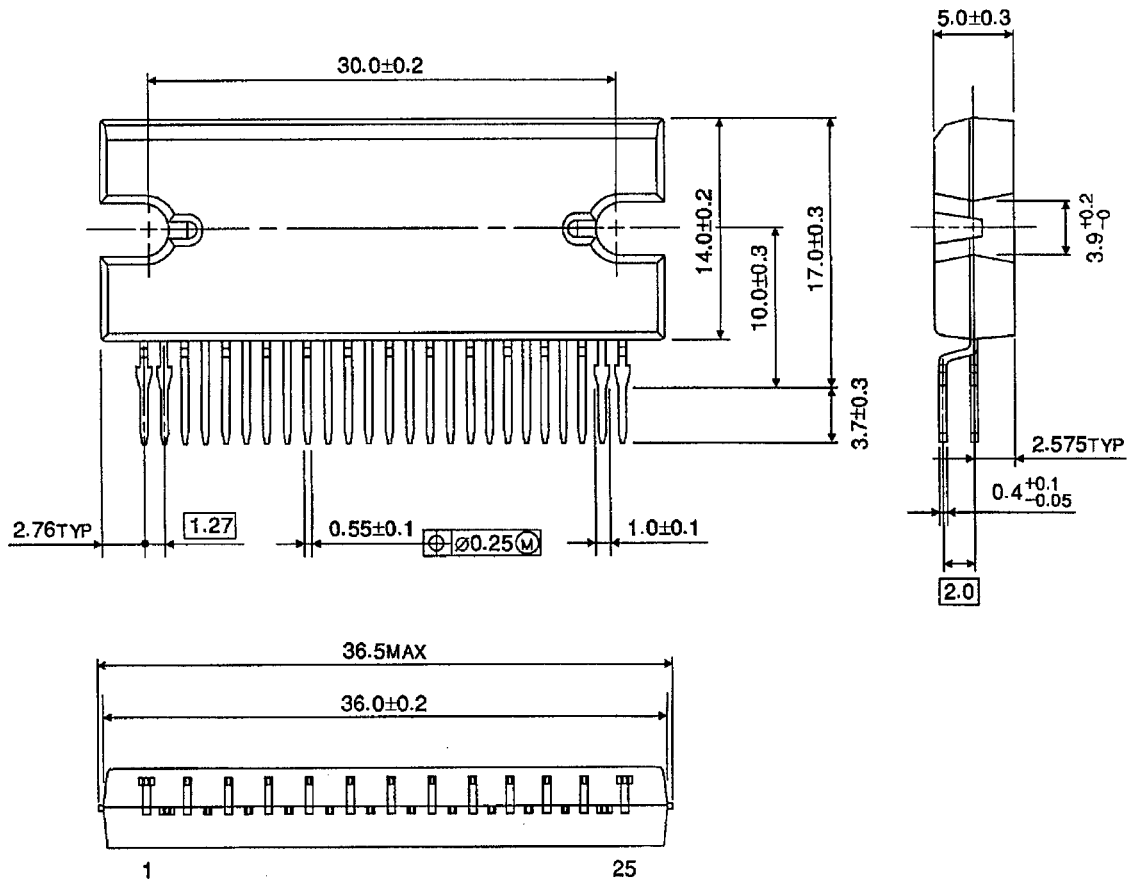

Weight: 9.86 g (typ.)

Notes on Contents

1. Block Diagrams

Some of the functional blocks, circuits, or constants in the block diagram may be omitted or simplified for explanatory purposes.

2. Equivalent Circuits

The equivalent circuit diagrams may be simplified or some parts of them may be omitted for explanatory purposes.

3. Timing Charts

Timing charts may be simplified for explanatory purposes.

4. Application Circuits

The application circuits shown in this document are provided for reference purposes only. Thorough evaluation is required, especially at the mass production design stage.

Toshiba does not grant any license to any industrial property rights by providing these examples of application circuits.

5. Test Circuits

Components in the test circuits are used only to obtain and confirm the device characteristics. These components and circuits are not guaranteed to prevent malfunction or failure from occurring in the application equipment.

IC Usage Considerations

Notes on handling of ICs

- [1] The absolute maximum ratings of a semiconductor device are a set of ratings that must not be exceeded, even for a moment. Do not exceed any of these ratings.
Exceeding the rating(s) may cause the device breakdown, damage or deterioration, and may result injury by explosion or combustion.
- [2] Use an appropriate power supply fuse to ensure that a large current does not continuously flow in case of over current and/or IC failure. The IC will fully break down when used under conditions that exceed its absolute maximum ratings, when the wiring is routed improperly or when an abnormal pulse noise occurs from the wiring or load, causing a large current to continuously flow and the breakdown can lead smoke or ignition. To minimize the effects of the flow of a large current in case of breakdown, appropriate settings, such as fuse capacity, fusing time and insertion circuit location, are required.
- [3] If your design includes an inductive load such as a motor coil, incorporate a protection circuit into the design to prevent device malfunction or breakdown caused by the current resulting from the inrush current at power ON or the negative current resulting from the back electromotive force at power OFF. IC breakdown may cause injury, smoke or ignition.
Use a stable power supply with ICs with built-in protection functions. If the power supply is unstable, the protection function may not operate, causing IC breakdown. IC breakdown may cause injury, smoke or ignition.
- [4] Do not insert devices in the wrong orientation or incorrectly.
Make sure that the positive and negative terminals of power supplies are connected properly.
Otherwise, the current or power consumption may exceed the absolute maximum rating, and exceeding the rating(s) may cause the device breakdown, damage or deterioration, and may result injury by explosion or combustion.
In addition, do not use any device that is applied the current with inserting in the wrong orientation or incorrectly even just one time.

Points to remember on handling of ICs**(1) Heat Radiation Design**

In using an IC with large current flow such as power amp, regulator or driver, please design the device so that heat is appropriately radiated, not to exceed the specified junction temperature (T_j) at any time and condition. These ICs generate heat even during normal use. An inadequate IC heat radiation design can lead to decrease in IC life, deterioration of IC characteristics or IC breakdown. In addition, please design the device taking into consideration the effect of IC heat radiation with peripheral components.

(2) Back-EMF

When a motor rotates in the reverse direction, stops or slows down abruptly, a current flows back to the motor's power supply due to the effect of back-EMF. If the current sink capability of the power supply is small, the device's motor power supply and output pins might be exposed to conditions beyond maximum ratings. To avoid this problem, take the effect of back-EMF into consideration in system design.

RESTRICTIONS ON PRODUCT USE

060116EBA

- The information contained herein is subject to change without notice. 021023_D
- TOSHIBA is continually working to improve the quality and reliability of its products. Nevertheless, semiconductor devices in general can malfunction or fail due to their inherent electrical sensitivity and vulnerability to physical stress. It is the responsibility of the buyer, when utilizing TOSHIBA products, to comply with the standards of safety in making a safe design for the entire system, and to avoid situations in which a malfunction or failure of such TOSHIBA products could cause loss of human life, bodily injury or damage to property.
In developing your designs, please ensure that TOSHIBA products are used within specified operating ranges as set forth in the most recent TOSHIBA products specifications. Also, please keep in mind the precautions and conditions set forth in the "Handling Guide for Semiconductor Devices," or "TOSHIBA Semiconductor Reliability Handbook" etc. 021023_A
- The TOSHIBA products listed in this document are intended for usage in general electronics applications (computer, personal equipment, office equipment, measuring equipment, industrial robotics, domestic appliances, etc.). These TOSHIBA products are neither intended nor warranted for usage in equipment that requires extraordinarily high quality and/or reliability or a malfunction or failure of which may cause loss of human life or bodily injury ("Unintended Usage"). Unintended Usage include atomic energy control instruments, airplane or spaceship instruments, transportation instruments, traffic signal instruments, combustion control instruments, medical instruments, all types of safety devices, etc. Unintended Usage of TOSHIBA products listed in this document shall be made at the customer's own risk. 021023_B
- The products described in this document shall not be used or embedded to any downstream products of which manufacture, use and/or sale are prohibited under any applicable laws and regulations. 060106_Q
- The information contained herein is presented only as a guide for the applications of our products. No responsibility is assumed by TOSHIBA for any infringements of patents or other rights of the third parties which may result from its use. No license is granted by implication or otherwise under any patent or patent rights of TOSHIBA or others. 021023_C
- The products described in this document are subject to the foreign exchange and foreign trade laws. 021023_E