

4-BIT SINGLE-CHIP MICROCOMPUTER

DESCRIPTION

The μ PD75216A is a microcomputer with a CPU capable of 1-, 4-, and 8-bit data processing, ROM, RAM, I/O ports, a fluorescent display tube controller/driver, a watch timer, a timer/pulse generator capable of outputting 14-bit PWM, a serial interface and a vectored interrupt function integrated on a single-chip.

The μ PD75216A is a product with the ROM capacity and the number of display segments extended for the μ PD75208.

It uses the VCR, ECR and CD fluorescent display tubes as display devices and is most suitable for applications requiring the timer/watch function and high-speed interrupt servicing. It can help to provide the unit with many functions and to decrease performance costs.

Functions are described in detail in the following User's Manual. Be sure to read when carrying out design work.

μ PD75216A User's Manual: IEM-988

FEATURES

- Architecture equal to that of an 8-bit microcomputer
- High-speed operation : Minimum instruction execution time : 0.95 μ s (when operated at 4.19 MHz)
- Instruction execution time variable function realizing a wide range of operating voltages
- On-chip large-capacity program memory : 16K bytes
- Watch operation with an ultra low current consumption : 5 μ A TYP. (at the 3 V operation)
- On-chip programmable fluorescent display tube controller/driver
- Timer function : 4 ch
 - 14-bit PWM output capability with the voltage synthesizer type electronic tuner
 - Buzzer output capability
- Interrupt function with importance attached to applications
 - For power-off detection
 - For remote controlled reception
- Product with an on-chip PROM : μ PD75P216A, μ PD75P218 (on-chip EPROM : WQFN package)

APPLICATION FIELD

VCR, CD player, ECR, etc.

The information in this document is subject to change without notice.

ORDERING INFORMATION

Ordering Code	Package	Quality Grade
μPD75216ACW-xxx	64-pin plastic shrink DIP (750 mil)	Standard
μPD75216AGF-xxx-3BE	64-pin plastic QFP (14 × 20 mm)	Standard

Remarks xxx is a ROM code number.

Please refer to "Quality grade on NEC Semiconductor Devices" (Document number IEI-1209) published by NEC Corporation to know the specification of quality grade on the devices and its recommended applications.

LIST OF FUNCTIONS

Item		Function		
Instruction execution time		<ul style="list-style-type: none"> • 0.95, 1.91, 15.3 μs (Main system clock : 4.19 MHz operation) • 122 μs (Subsystem clock : 32.768 kHz operation) 		
On-chip memory	ROM	16256 × 8 bits		
	RAM	512 × 4 bits		
General register		<ul style="list-style-type: none"> • 4-bit manipulation : 8 × 4 banks • 8-bit manipulation : 4 × 4 banks 		
Input/output port <div style="border-left: 1px solid black; border-right: 1px solid black; padding: 2px; display: inline-block;"> FIP® dual-function pin included FIP dedicated pin excluded </div>	33	8	CMOS input pin	
		20	CMOS input/output pins	<ul style="list-style-type: none"> • Direct LED drive capability : 8 • On-chip pull-down resistor by mask option capability : 4
		1	CMOS output pin	PWM/pulse output
		4	P-ch open-drain, high-voltage, high-current output pin	<ul style="list-style-type: none"> • LED drive capability • On-chip pull-down resistor by mask option capability
FIP controller/driver		<ul style="list-style-type: none"> • No. of segments : 9 to 16 segments • No. of digits : 9 to 16 digits • Dimmer function : 8 levels • On-chip pull-down resistor by mask option capability • Key scan interrupt generation 		
Timer		4 channels	<ul style="list-style-type: none"> • Timer/pulse generator : 14-bit PWM output enabled • Watch timer : Buzzer output enabled • Timer/event counter • Basic interval timer : Watchdog timer application capability 	
Serial interface		<ul style="list-style-type: none"> • MSB start/LSB start switchable • Serial bus configuration capability 		
Vectored interrupt		External : 3, Internal : 5		
Test input		External : 1, Internal : 1		
System clock oscillator		<ul style="list-style-type: none"> • Ceramic/crystal oscillator for main system clock oscillation : 4.194304 MHz standard • Crystal oscillator for subsystem clock oscillation : 32.768 kHz standard 		
Standby function		STOP/HALT mode		
Mask option		<ul style="list-style-type: none"> • Power-on reset, power-on flag • High withstand voltage port : Pull-down resistor or open-drain output • Port 6 : Pull-down resistor 		
Operating temperature range		-40 to +85 °C		
Operating voltage		2.7 to 6.0 V (standby data hold : 2.0 to 6.0 V)		
Package		<ul style="list-style-type: none"> • 64-pin plastic shrink DIP (750 mil) • 64-pin plastic QFP (14 × 20 mm) 		

CONTENTS

1. PIN CONFIGURATION (TOP VIEW)	6
2. BLOCK DIAGRAM	8
3. PIN FUNCTIONS	9
3.1 PORT PINS	9
3.2 NON-PORT PINS	10
3.3 PIN INPUT/OUTPUT CIRCUIT LIST	11
3.4 UNUSED PINS TREATMENT	12
3.5 P00/INT4 PIN AND RESET PIN OPERATING PRECAUTIONS	13
3.6 XT1, XT2 AND P50 PIN OPERATING PRECAUTIONS	13
4. MEMORY CONFIGURATION	14
5. PERIPHERAL HARDWARE FUNCTIONS	17
5.1 PORTS	17
5.2 CLOCK GENERATOR	18
5.3 BASIC INTERVAL TIMER	19
5.4 WATCH TIMER	20
5.5 TIMER/EVENT COUNTER	21
5.6 TIMER/PULSE GENERATOR	22
5.7 SERIAL INTERFACE	23
5.8 FIP CONTROLLER /DRIVER	25
5.9 POWER-ON FLAG (MASK OPTION)	27
6. INTERRUPT FUNCTIONS	28
7. STANDBY FUNCTIONS	30
8. RESET FUNCTIONS	31
9. INSTRUCTION SET	34
10. MASK OPTION SELECTION	43
11. APPLICATION BLOCK DIAGRAM	44
11.1 VCR TIMER TUNER	44
11.2 CD PLAYER	45
11.3 ECR	45
12. ELECTRICAL SPECIFICATIONS	46
13. CHARACTERISTIC CURVES	59
14. PACKAGE INFORMATION	63

15. RECOMMENDED SOLDERING CONDITIONS	66
APPENDIX A. LIST OF μPD75216A SERIES PRODUCT FUNCTIONS	67
APPENDIX B. DEVELOPMENT TOOLS	69
APPENDIX C. RELATED DOCUMENTS	70

1. PIN CONFIGURATION (TOP VIEW)

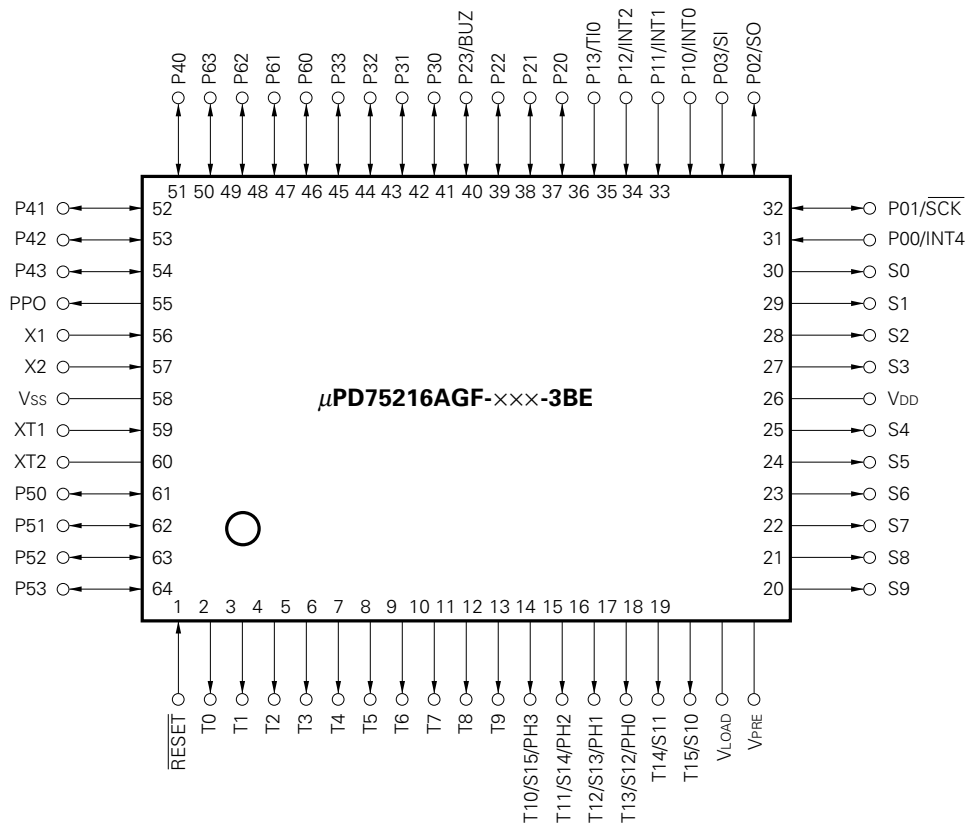
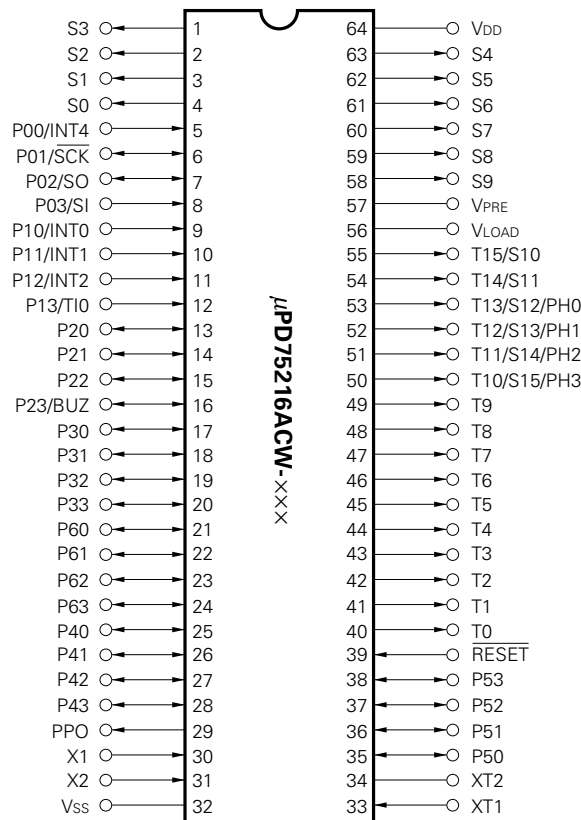

PIN NAME

P00-P03	: Port 0	$\overline{\text{SCK}}$: Serial Clock
P10-P13	: Port 1	SO	: Serial Output
P20-P23	: Port 2	SI	: Serial Input
P30-P33	: Port 3	INT0, INT1, INT4	: External Vectored Interrupt 0, 1, 4
P40-P43	: Port 4	INT2	: External Test Input 2
P50-P53	: Port 5	TI0	: Timer Input 0
P60-P63	: Port 6	X1, X2	: Main System Clock Oscillation 1, 2
PH0-PH3	: Port H	XT1, XT2	: Subsystem Clock Oscillation 1, 2
T0-T15	: Digit Output 0-15	$\overline{\text{RESET}}$: Reset Input
S0-S15	: Segment Output 0-15	$V_{\text{LOAD}}, V_{\text{PRE}}$: FIP Driver Power Supply Pin
PPO	: Pulse Output		
BUZ	: Fixed Frequency Output		

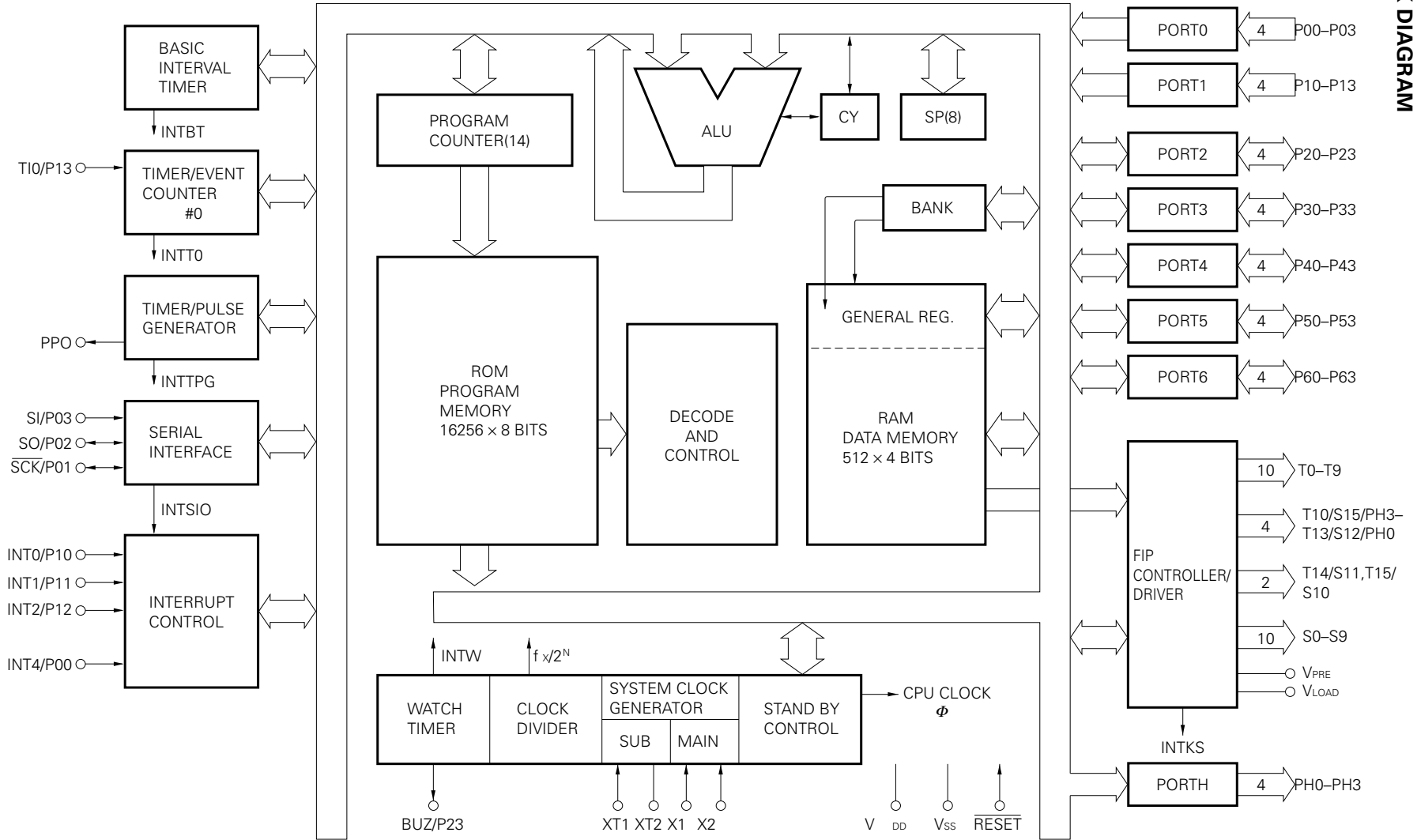

2. BLOCK DIAGRAM

3. PIN FUNCTIONS

3.1 PORT PINS

Pin Name	I/O	Dual-Function Pin	Function	8-Bit I/O	After Reset	Input / Output Circuit Type *	
P00	Input	INT4	4-bit input port (PORT0).	×	Input	ⓑ	
P01	Input/output	SCK				ⓕ	
P02	Input/output	SO				ⓖ	
P03	Input	SI				ⓑ	
P10	Input	INT0	4-bit input port (PORT1). Noise elimination function available		Input	ⓑ	
P11		INT1					Noise elimination function available
P12		INT2					
P13		T10					
P20	Input/output	—	4-bit input/output port (PORT2).	×	Input	E	
P21		—					
P22		—					
P23		BUZ					
P30 to P33	Input/output	—	Programmable 4-bit input/ output port (PORT3). Input/output specifiable in 1-bit units.		Input	E	
P40 to P43	Input/output	—	4-bit input/output port (PORT4). LED direct drive capability.	○	Input	E	
P50 to P53	Input/output	—	4-bit input/output port (PORT5). LED direct drive capability.		Input	E	
P60 to P63	Input/output	—	Programmable 4-bit input/output port (PORT6). Input/output specifiable in bit-wise. On-chip pull-down resistor available (mask option). Suitable for key input.	×	Input	V	
PH0	Output	T13/S12	4-bit P-ch open-drain, high-voltage, high-current output port (PORTH). LED direct drive capability. On-chip pull-down resistor available (mask option).	×	Low level (with an on-chip pull-down resistor) or high impedance.	I	
PH1		T12/S13					
PH2		T11/S14					
PH3		T10/S15					

* Schmitt-triggered inputs are circled.

3.2 NON-PORT PINS

Pin Name	I/O	Dual-Function Pin	Function	After Reset	Input / Output Circuit Type *
T0 to T9	Output	—	FIP controller/driver output pins. Pull-down resistor can be incorporated in bit-wise (mask option).	Digit output high-voltage high-current output.	Low level (With an on-chip pull-down resistor) or high impedance (without a pull-down resistor)
T10/S15 to T13/S12		PH3 to PH0		Digit/segment output dual-function high-voltage high-current output. Extra pins can be used as PORTH.	
T14/S11, T15/S10		—		Digit/segment output dual-function high-voltage high-current output. Static output also possible.	
S9		—		Segment output high voltage output. Static output also possible.	
S0 to S8		—		Segment high-voltage output.	
PPO	Output	—	Timer/pulse generator pulse output.	High impedance	D
T10	Input	P13	External event pulse input for timer/event counter.		ⓑ
$\overline{\text{SCK}}$	Input/output	P01	Serial clock input/output.	Input	Ⓕ
SO	Input/output	P02	Serial data input pin or serial data input/output.	Input	Ⓖ
SI	Input	P03	Serial data input or normal input.	Input	ⓑ
INT4	Input	P00	Edge-detected vectored interrupt input (rising and falling edge detection).		ⓑ
INT0	Input	P10	Edge-detected vectored interrupt input with noise elimination function (detection edge selection possible).		ⓑ
INT1		P11			
INT2	Input	P12	Edge-detected testable input (rising edge detection).		ⓑ
BUZ	Input/output	P23	Fixed frequency output (for buzzer or system clock trimming).	Input	E
X1, X2	Input	—	Crystal/ceramic connect pin for main system clock oscillation. External clock input to X1 and its inverted clock input to X2.		
XT1	Input	—	Crystal connect pin for subsystem clock oscillation. External clock input to XT1 and XT2 open.		
XT2	—				
$\overline{\text{RESET}}$	Input	—	System reset input (low level active).		ⓑ
V _{PRE}		—	FIP controller/driver output buffer power supply.		I
V _{LOAD}		—	FIP controller/driver pull-down resistor connect pin.		I
V _{DD}		—	Positive power supply.		
V _{SS}		—	GND potential.		

* Schmitt-triggered inputs are circled.

3.3 PIN INPUT/OUTPUT CIRCUIT LIST

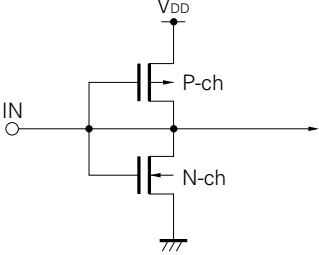
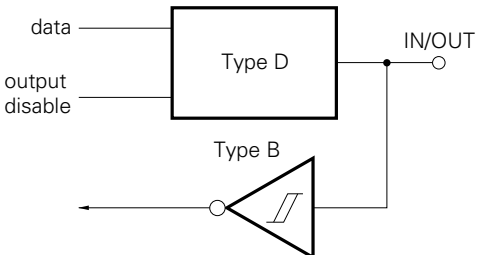
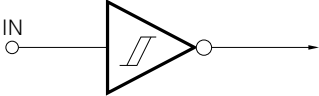
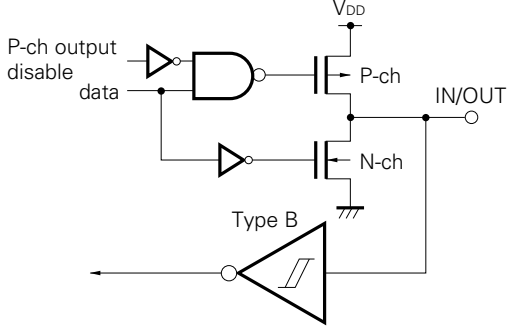
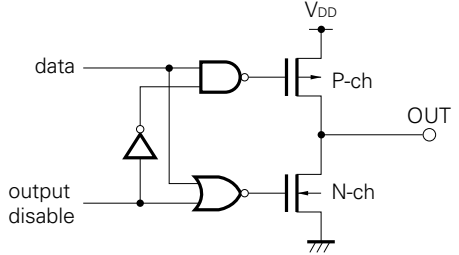
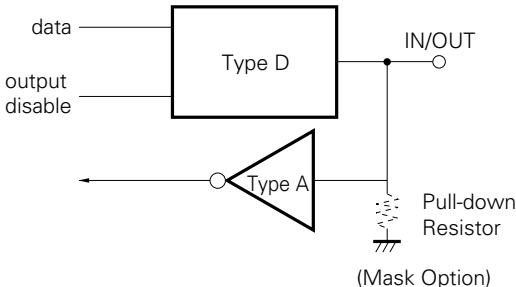
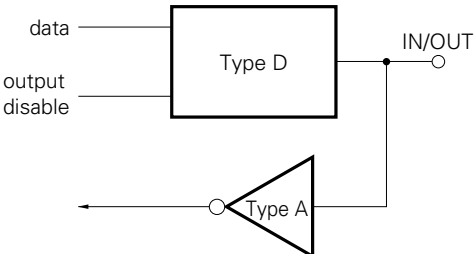
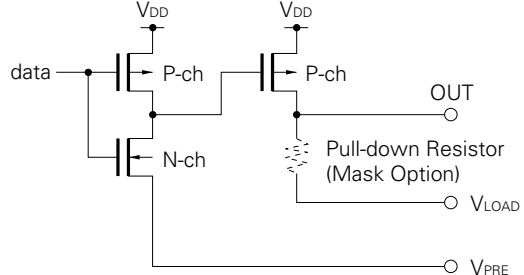
<p>TYPE A</p>  <p>CMOS-Specified Input Buffer</p>	<p>TYPE F</p>  <p>Input/Output Circuit Consisting of Type D Push-Pull Output and Type B Schmitt-Triggered Input</p>
<p>TYPE B</p>  <p>Schmitt-Triggered Input Having Hysteresis Characteristics</p>	<p>TYPE G</p>  <p>Input/Output Circuit Capable of Switching between Push-Pull Output and N-ch Open-Drain Output (with P-ch OFF).</p>
<p>TYPE D</p>  <p>Push-Pull Output which can be Set to Output High Impedance (with Both P-ch and N-ch Set to OFF)</p>	<p>TYPE V</p>  <p>Pull-down Resistor (Mask Option)</p>
<p>TYPE E</p>  <p>Input/Output Circuit Consisting of Type D Push-Pull Output and Type A Input Buffer</p>	<p>TYPE I</p>  <p>Pull-down Resistor (Mask Option)</p> <p>VLOAD</p> <p>VPRE</p>

3.4 UNUSED PINS TREATMENT

Pin	Recommended Connection
P00/INT4	Connect to V _{SS}
P01/ $\overline{\text{SCK}}$	Connect to V _{SS} or V _{DD}
P02/SO	
P03/SI	
P10/INT0 to P12/INT2	Connect to V _{SS}
P13/TI0	
P20 to P22	Input state : Connect to V _{SS} or V _{DD} Output state : Leave open
P23/BUZ	
P30 to P33	
P40 to P43	
P50 to P53	
P60 to P63	
PPO	
S0 to S9	
T15/S10 to T14/S11	
T0 to T9	
T10/S15/PH3 to T13/S12/PH0	
XT1	Connect to V _{SS} or V _{DD}
XT2	Leave open
$\overline{\text{RESET}}$ when there is an on-chip power-on reset circuit	Connect to V _{DD}
V _{LOAD} when there is no on-chip load resistor	Connect to V _{SS} or V _{DD}

3.5 P00/INT4 PIN AND RESET PIN OPERATING PRECAUTIONS

P00/INT4 and RESET pins have the function (especially for IC test) to test μPD75216A internal operations in addition to the functions described in sections 3.1 and 3.2.

The test mode is set when a voltage larger than V_{DD} is applied to one of these pins. If noise larger than V_{DD} is applied in normal operation, the test mode may be set thereby adversely affecting normal operation.

Since there is a display output pin having a high-voltage amplitude (35 V) next to the P00/INT4 and RESET pins, if cables for the related signals are routed in parallel, wiring noise larger than V_{DD} may be applied to the P00/INT4 and RESET pins causing errors.

Thus, carry out wiring so that wiring noise can be minimized, If noise still cannot be suppressed, take the measure against noise using the following external components.

- Connect diode with small V_F (0.3 V or less) between V_{DD} and P00/INT4, RESET
- Connect a capacitor between the pins and V_{DD}.



3.6 XT1, XT2 AND P50 PIN OPERATING PRECAUTIONS

When selecting the 32.768 kHz subsystem clock connected to the XT1 and XT2 pins as the watch timer source clock, the signal to be input or output to the P50 pin next to the XT2 pin must be a signal required to be switched between high and low the minimum number of times (once or less per second).

If the P50 pin signal is switched frequently between high and low, a spike is generated in the XT2 pin because of capacitance coupling of the P50 and XT2 pins and the correct watch functions cannot be achieved (the watch becomes fast).

If it is necessary to allow the P50 pin signal to switch between high and low, mount an external capacitor to the P50 pin as shown below.

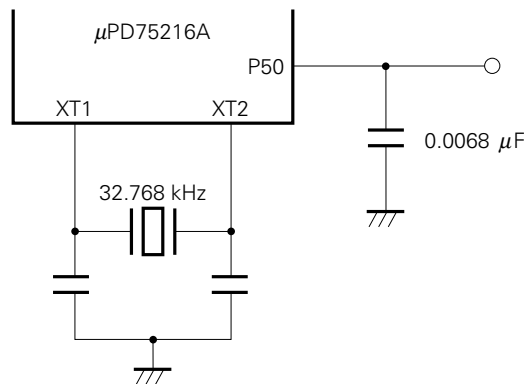

4. MEMORY CONFIGURATION

- Program memory (ROM) 16256 words \times 8 bits
 - 0000H to 0001H : Vector table for writing program start address by reset
 - 0002H to 000FH : Vector table for writing program start address by interrupt
 - 0020H to 007FH : Table area to be referred to by GETI instruction

- Data Memory
 - Data area 512 words \times 4 bits (000H to 1FFH)
 - Peripheral hardware area 128 words \times 4 bits (F80H to FFFH)

Fig. 4-1 Program Memory Map

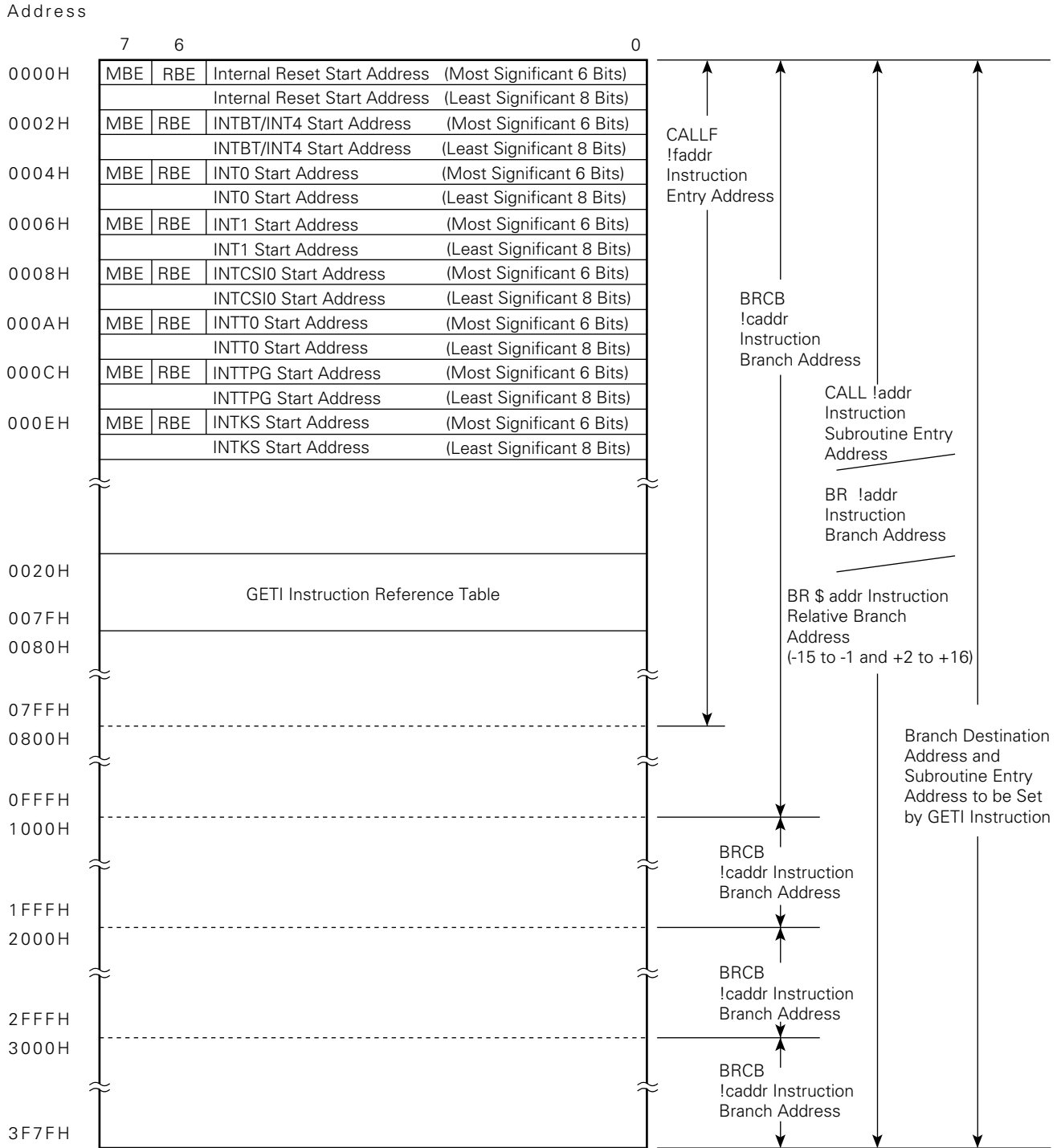

Remarks In all cases other than those listed above, branch to the address with only the lower 8 bits of the PC changed is enabled by BR PCDE and BR PCXA instructions.

Fig. 4-2 Data Memory Map

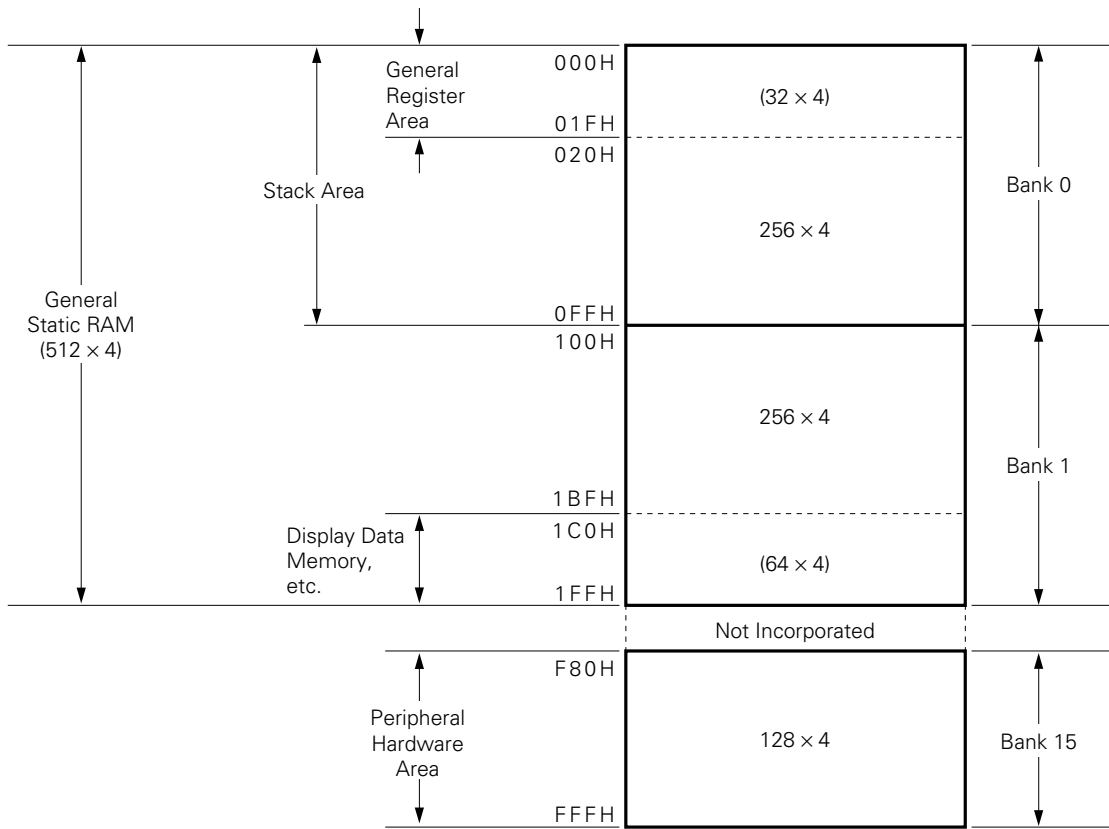

5. PERIPHERAL HARDWARE FUNCTIONS

5.1 PORTS

I/O ports have the following three functions.

- CMOS input (PORT0, 1) : 8
 - CMOS input/output (PORT2, 3, 4, 5, 6) : 20
 - P-ch open-drain, high-voltage, high-current output (PORTH) : 4
-
- Total 32

Table 5-1 Port Functions

Port Name	Function	Operation and Feature	Remarks
PORT0	4-bit input	Always read or test possible irrespective of the dual-function pin operating mode.	Shares the pins with SI, SO, \overline{SCK} and INT4.
PORT1		Always read or test possible, P10 and P11 are inputs with the noise elimination function.	Shares the pins with INT0 to INT 2 and T10.
PORT3 PORT6	4-bit input/output	Can be set bit-wise to the input or output mode. Port 6 can incorporate a pull-down resistor as a mask option.	
PORT2 PORT4 PORT5		Can be set to the input or output mode in 4-bit units. Ports 4 and 5 can input/output data in pairs in 8-bit units. Ports 4 and 5 can directly drive LEDs.	P23 shares the pin with BUZ.
PORTH		4-bit output	P-ch open-drain high-voltage, high-current output port. Can drive an FIP and LED directly. Can incorporate a pull-down resistor bit-wise as a mask option.

5.2 CLOCK GENERATOR

The clock generator operations are determined by the processor clock control register (PCC) and the system clock control register (SCC).

The clock generator has two types: main system clock and subsystem clock.

The instruction execution time can be changed.

- 0.95 μs, 1.91 μs, 15.3 μs (Main system clock: at 4.19 MHz operation)
- 122 μs (Subsystem clock: at 32.768 kHz operation)

Fig. 5-1 Clock Generator Block Diagram

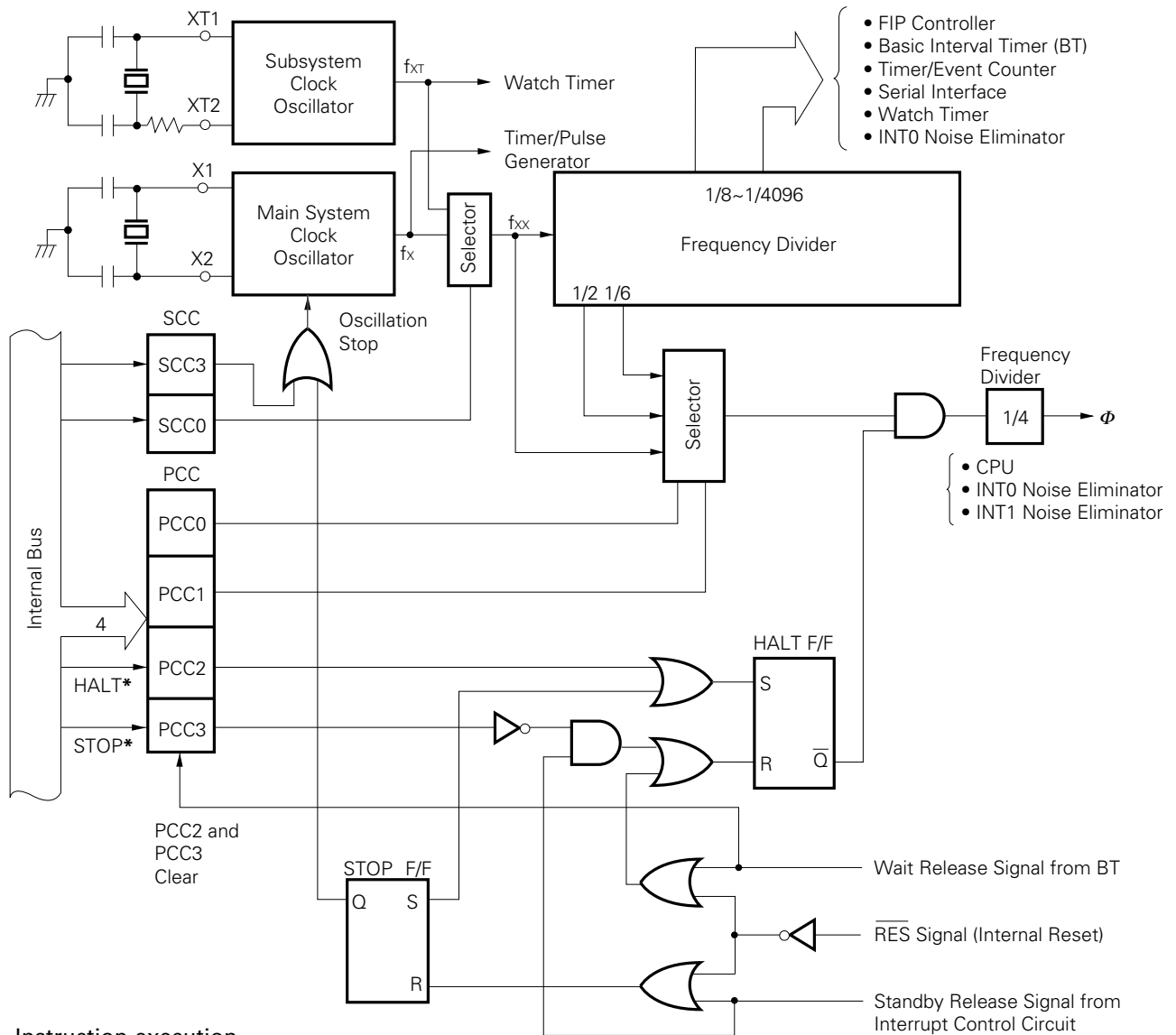

* Instruction execution

- Remarks**
1. f_x = Main system clock frequency
 2. f_{XT} = Subsystem clock frequency
 3. f_{xx} = System clock frequency
 4. Φ = CPU clock
 5. PCC: Processor clock control register
 6. SCC: System clock control register
 7. 1 clock cycle (t_{CY}) of Φ is 1 machine cycle of an instruction. For t_{CY} , see "AC Characteristics" in 12.

ELECTRICAL SPECIFICATIONS.

5.3 BASIC INTERVAL TIMER

The basic interval timer has the following functions:

- Interval timer operation to generate reference time
- Watchdog timer application to detect inadvertent program loop
- Wait time select and count upon standby mode release
- Count contents read

Fig. 5-2 Basic Interval Timer Configuration

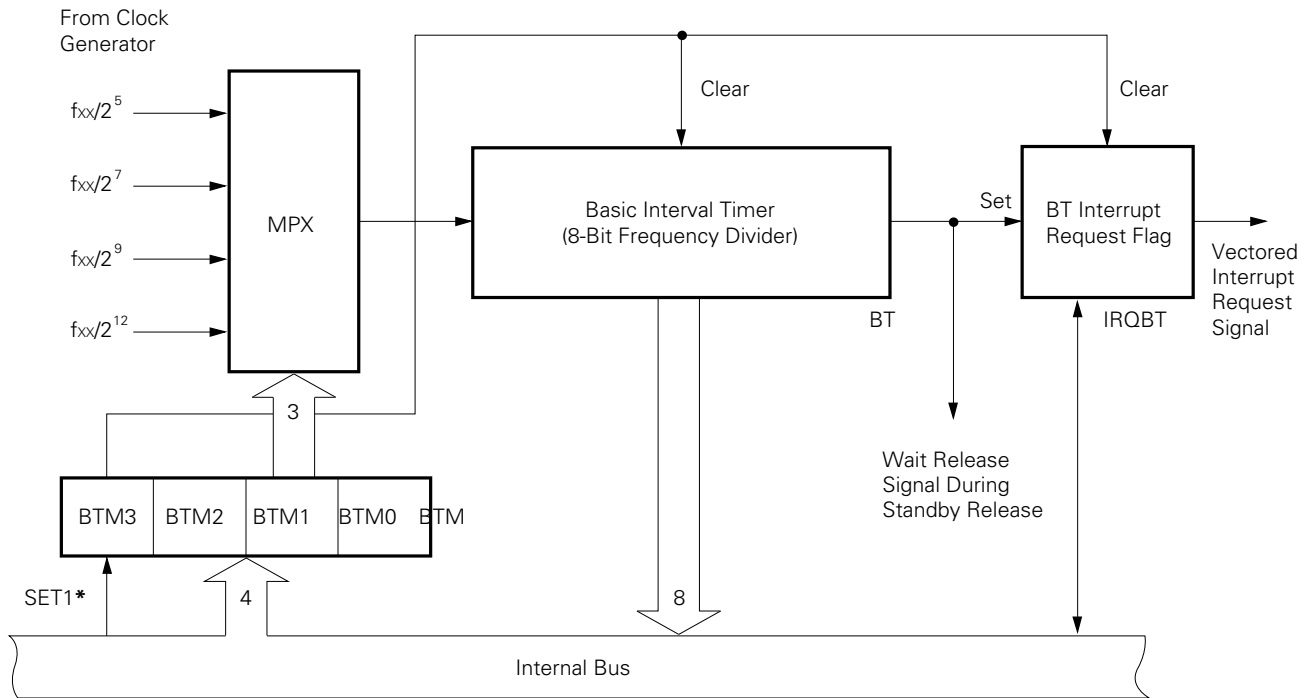

* Instruction execution

5.4 WATCH TIMER

The μPD75216A incorporates one channel of watch timer. The watch timer has the following functions.

- Sets the test flag (IRQW) at 0.5 sec intervals.
The standby mode can be released by IRQW.
- 0.5 second interval can be set with the main system clock and subsystem clock.
- The fast mode enables to set 128-time (3.91 ms) interval useful to program debugging and inspection.
- The fixed frequencies (2.048 kHz) can be output to the P23/BUZ pin for use to generate buzzer sound and trim the system clock oscillator frequency.
- Since the frequency divider can be cleared, the watch can be started from zero second.

Fig. 5-3 Watch Timer Block Diagram

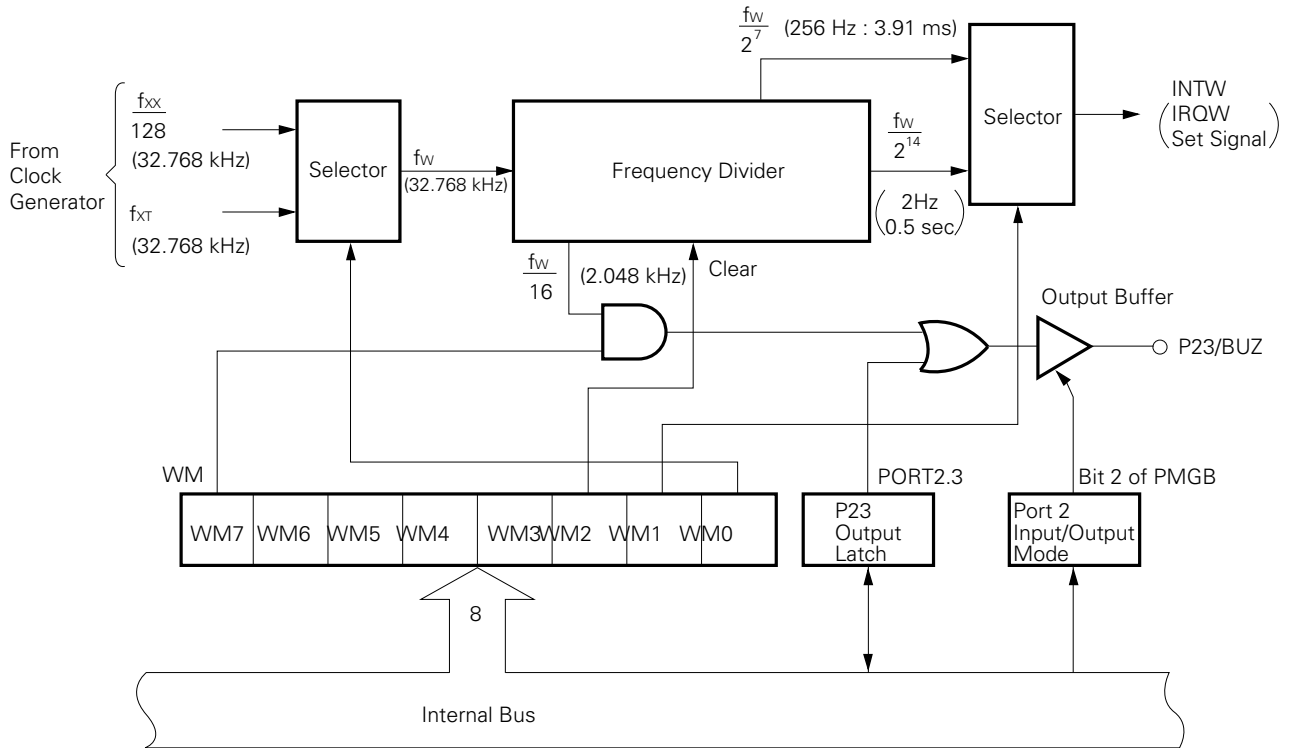

Remarks Values at $f_{xx} = 4.194304$ MHz and $f_{xt} = 32.768$ kHz are indicated in parentheses.

5.5 TIMER/EVENT COUNTER

The μPD75216A incorporates one channel of timer/event counter. The timer/event counter has the following functions.

- Program interval timer operation
- Event counter operation
- Count state read function

Fig. 5-4 Timer/Event Counter Block Diagram

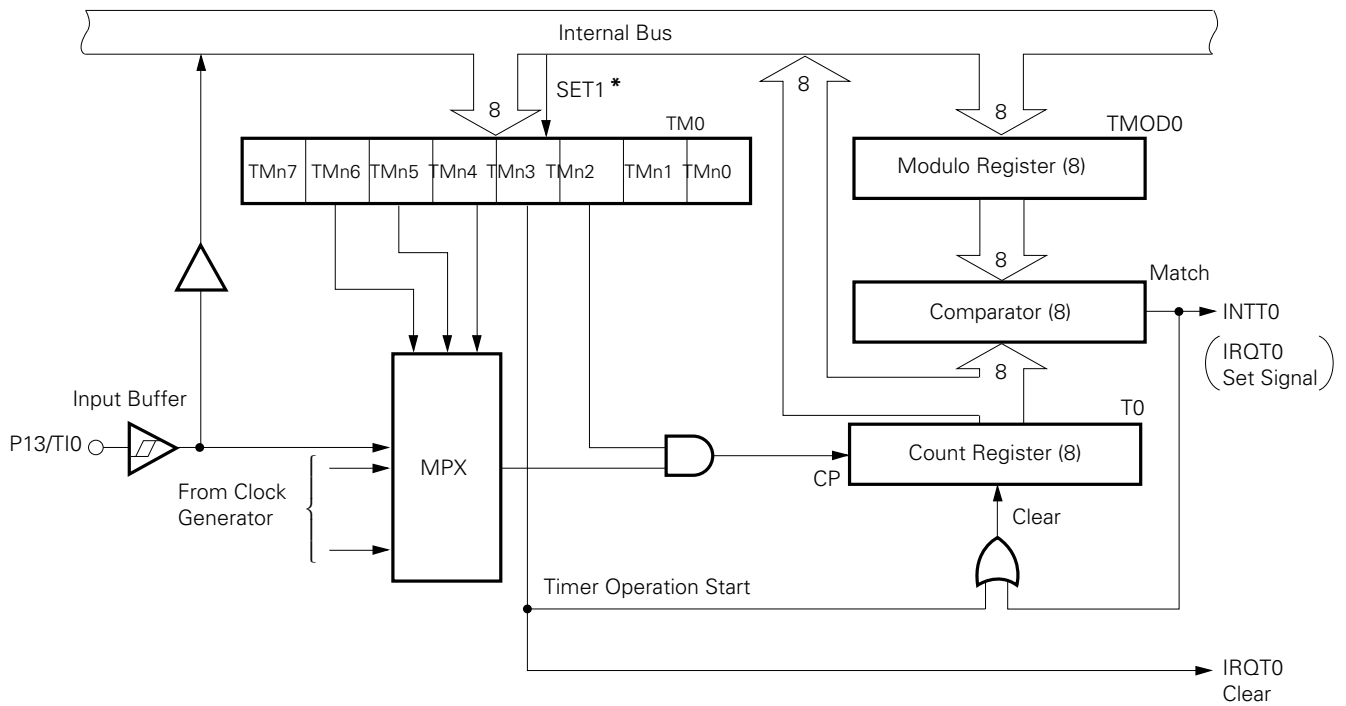

* Instruction execution.

5.6 TIMER/PULSE GENERATOR

The μPD75216A incorporates one channel of timer/pulse generator which can be used as a timer or a pulse generator. The timer/pulse generator has the following functions.

(a) Functions available in the timer mode

- 8-bit interval timer operation (IRQTPG generation) enabling the clock source to be varied at 5 levels
- Square wave output to PPO pin

(b) Functions available in the PWM pulse generation mode

- 14-bit accuracy PWM pulse output to the PPO pin (Used as a digital-to-analog converter and applicable to tuning)
- Fixed time interval ($\frac{2^{15}}{f_{XX}} = 7.81 \text{ ms}$: at 4.19 MHz operation) interrupt generation

If pulse output is not necessary, the PPO pin can be used as a 1-bit output port.

Note If the STOP mode is set while the timer/pulse generator is in operation, miss-operation may result. To prevent that from occurring, preset the timer/pulse generator to the stop state using its mode register.

Fig. 5-5 Block Diagram of Timer/Pulse Generator (Timer Mode)

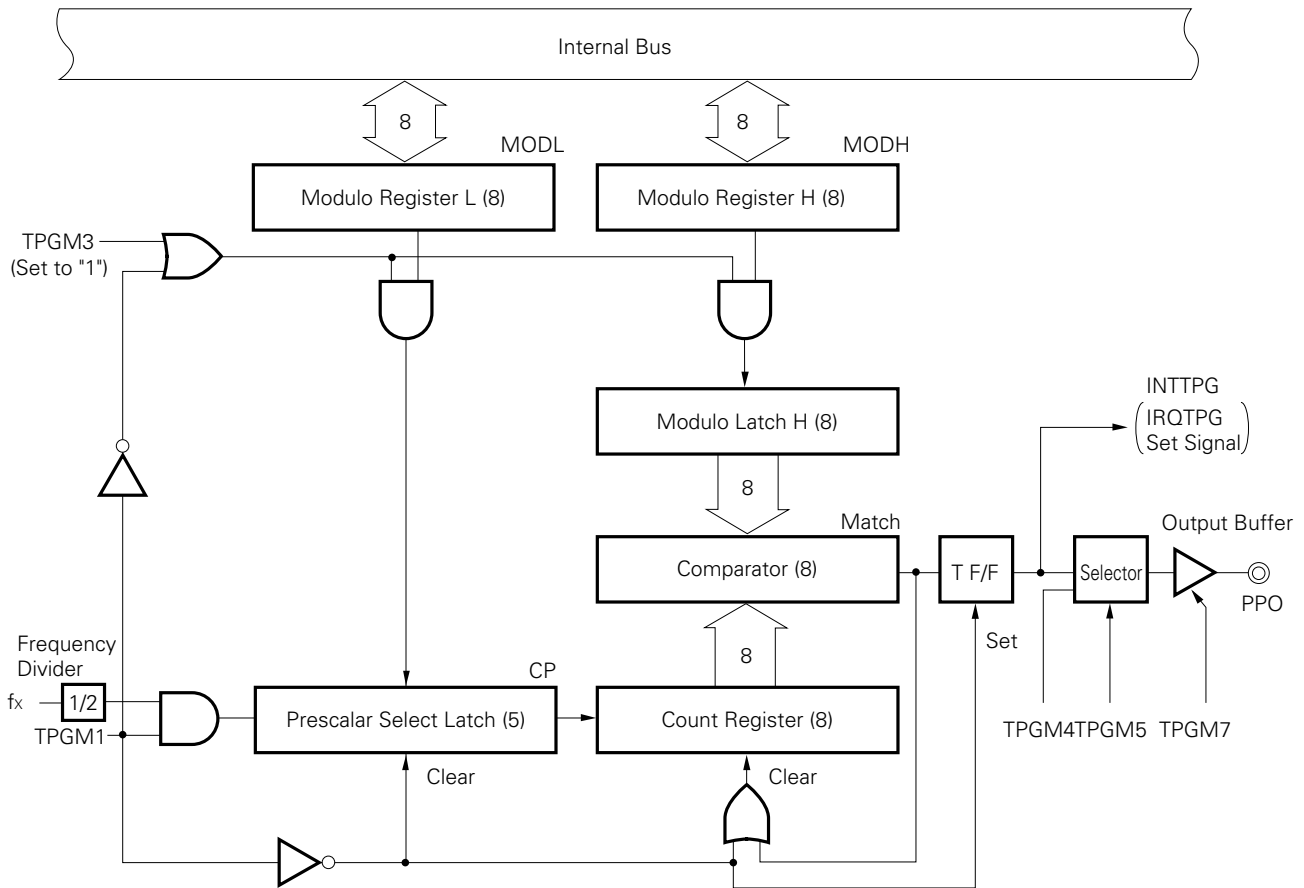
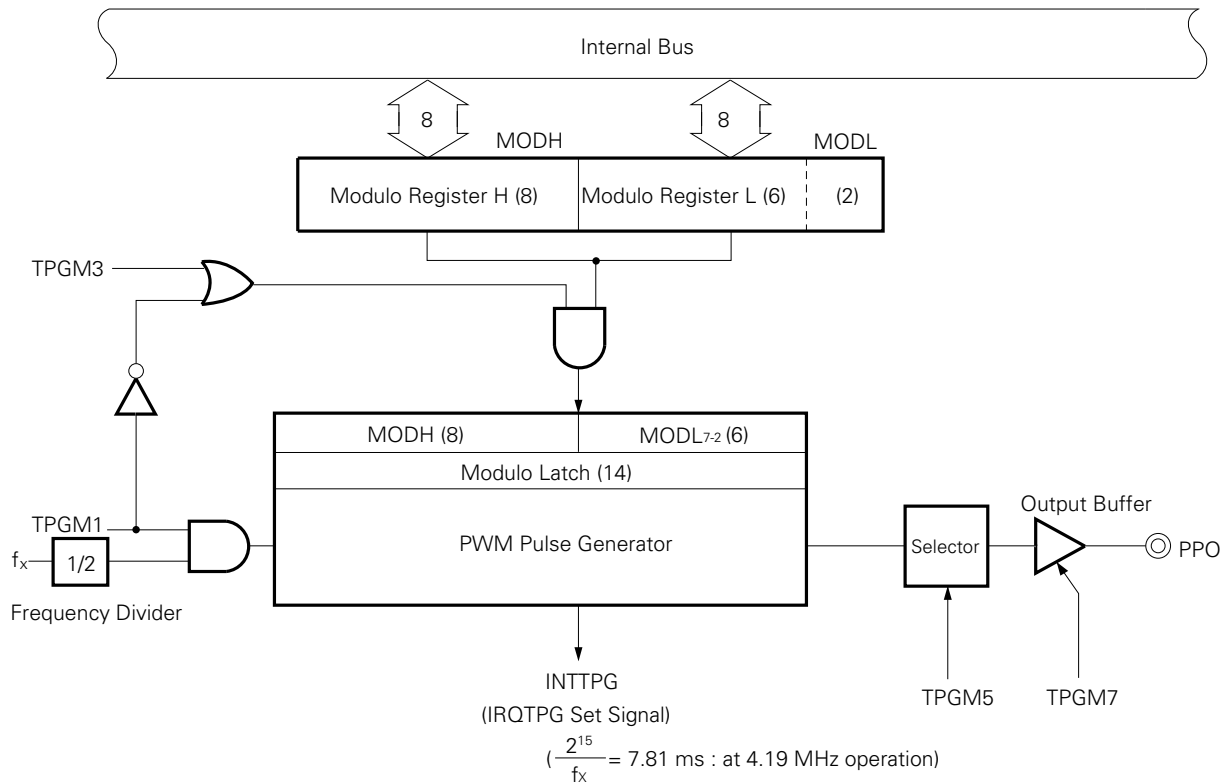

Fig. 5-6 Timer/Pulse Generator Block Diagram (PWM Pulse Generation Mode)



5.7 SERIAL INTERFACE

The μPD75216A serial interface has the following functions.

- Clock synchronous 8-bit send/receive operation (simultaneous send/receive)
- Clock synchronous 8-bit serial bus operation (data input/output from the SO pin. N-ch open-drain SO output)
- Start LSB/MSB switching

The above functions facilitates data communication with another microcomputer of μPD7500 series and 78K series via serial bus and coupling with peripheral devices.

Fig 5-7 Serial Interface Block Diagram

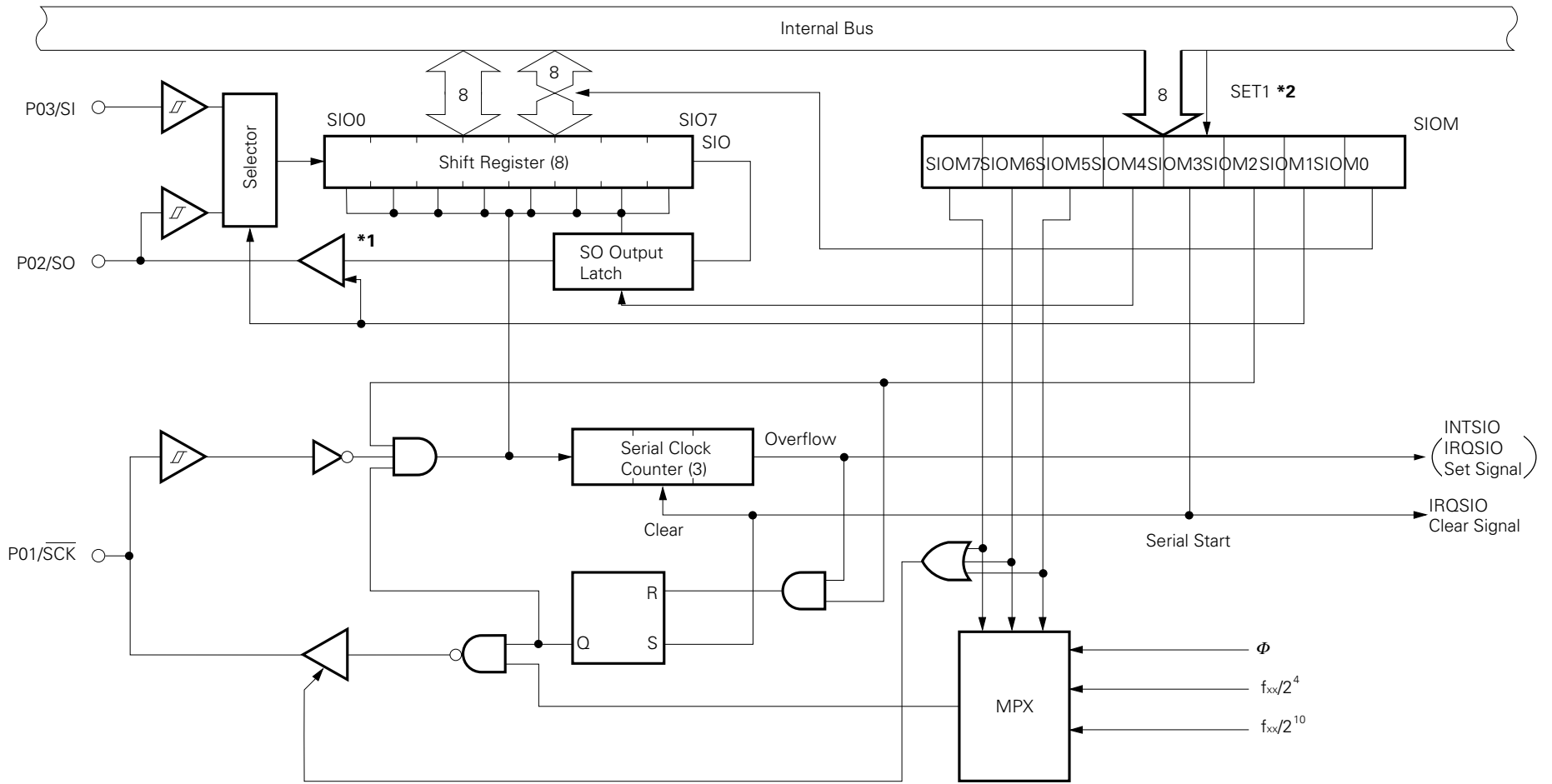

* 1. CMOS output and N-ch open drain output switchable output buffer.
 2. Instruction execution

5.8 FIP CONTROLLER/DRIVER

The on-chip FIP controller/driver has the following functions:

- Generates the segment and digit signals by automatically reading the display data memory executing DMA operation.
- Can select up to a total of 26 display devices in the range of 9 to 16 segments and 9 to 16 digits.
- Can apply the remaining display output as static output.
- Can adjust the brightness at 8 levels using the dimmer function.
- Can apply key scan operations.
 - Generates interrupt at the key scan timing (IRQKS)
 - Can generate key scan data output from the segment output pin.
- Owns the high-voltage output pin (40 V) which can directly drive the FIP.
 - Segment special pins (S0 to S9) : $V_{OD} = 40\text{ V}$, $I_{OD} = 3\text{ mA}$
 - Digit output pins (T0 to T15) : $V_{OD} = 40\text{ V}$, $I_{OD} = 15\text{ mA}$
- Can incorporate pull-down resistors bit-wise as mask options.

Differences between μPD75261A and μPD75238 display output function are shown in Table 5-2.

Table 5-2 Differences between μPD75216A and μPD75238 display output function

	μPD75216A	μPD75238
High-voltage output display	FIP output total : 26 Segment output : 9 to 16 Digit output : 9 to 16	FIP output total : 34 Segment output : 9 to 24 Digit output : 9 to 16
Display data area	1C0H to 1FFH	1A0H to 1FFH
Output dual-function pin	S12 to S15 (PORTH)	S0 to S23 (PORT10 to PORT15)
Key scan register	KS0, KS1	KS0 to KS2

Fig. 5-8 FIP Controller/Driver Block Diagram

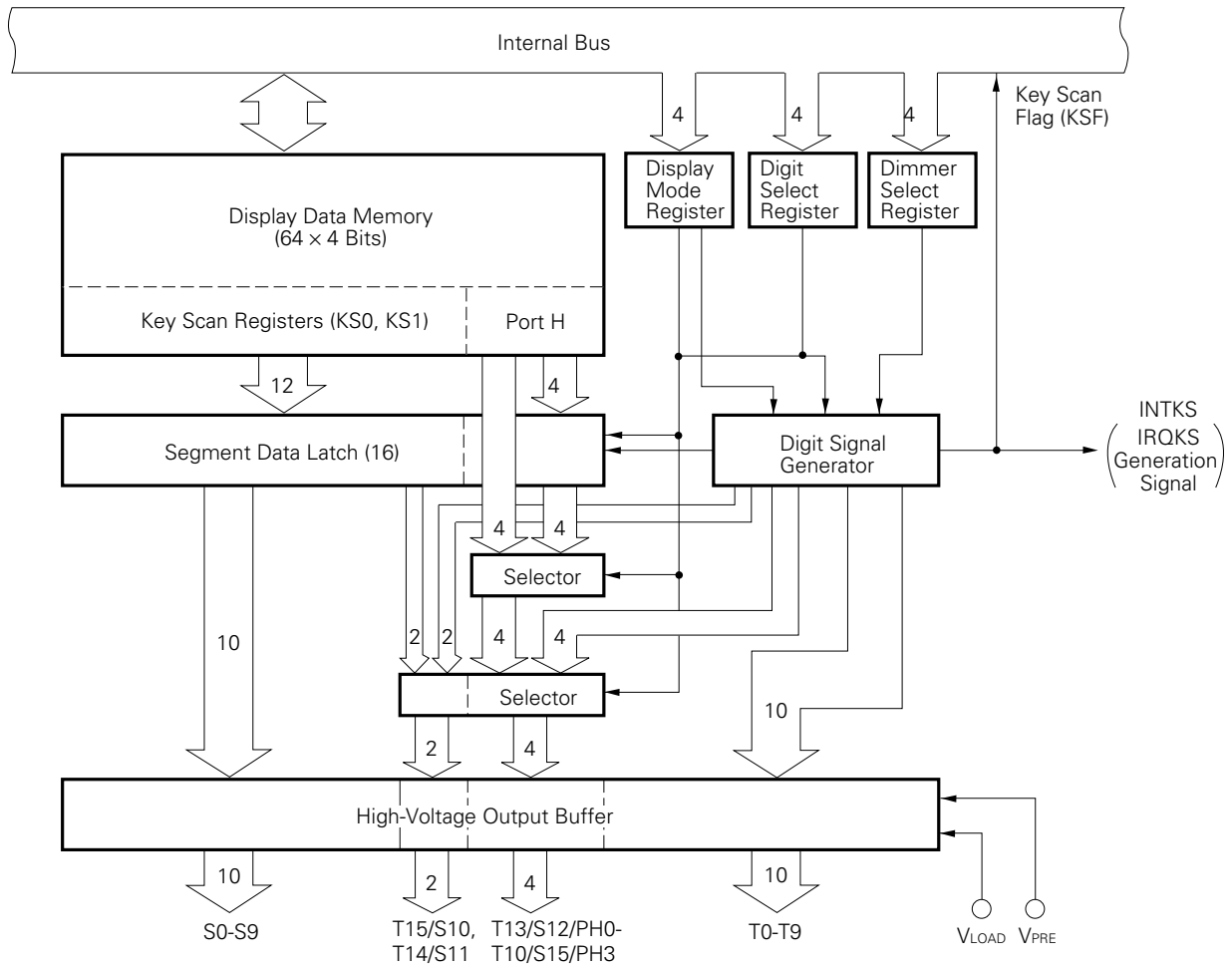

Note The FIP controller/driver can only operate in the high and intermediate-speeds (PCC = 0011B or 0010B) of the main system clock (SCC.0 = 0). It may cause errors with any other clock or in the standby mode. Thus, be sure to stop FIP controller operation (DSPM.3 = 0) and then shift the unit to any other clock mode or the standby mode.

5.9 POWER-ON FLAG (MASK OPTION)

The power-on flag (PONF) is automatically set (1) when the power-on reset circuit is activated and the power-on reset signal is generated (See **Fig. 8-1 Reset Signal Generator**).

The PONF is mapped at bit 0 of address FD1H in the data memory space and can be tested by the memory bit manipulation instructions (SKT, SKF, SKTCLR) or cleared (CLR1).

Note The PONF cannot be set by SET1 instruction.

6. INTERRUPT FUNCTIONS

The μPD75216A has eight types of interrupt sources and can generate multiple interrupts with priority order. It is also equipped with two types of test sources. INT2 is an edge detected testable input.

The μPD75216A interrupt control circuit has the following functions:

- Hardware-controller vectored interrupt function which can control interrupt acknowledge with the interrupt enable flag (IE_{xxx}) and the interrupt master enable flag (IME).
- Function of setting any interrupt start address.
- Multiple interrupt function which can specify priority order with the interrupt priority select register (IPS).
- Interrupt request flag (IRQ_{xxx}) test function. (Interrupt generation can be checked by software.)
- Standby mode release function. (Interrupt to be released by interrupt enable flag can be selected.)

Fig. 6-1 Interrupt Control Circuit Block Diagram

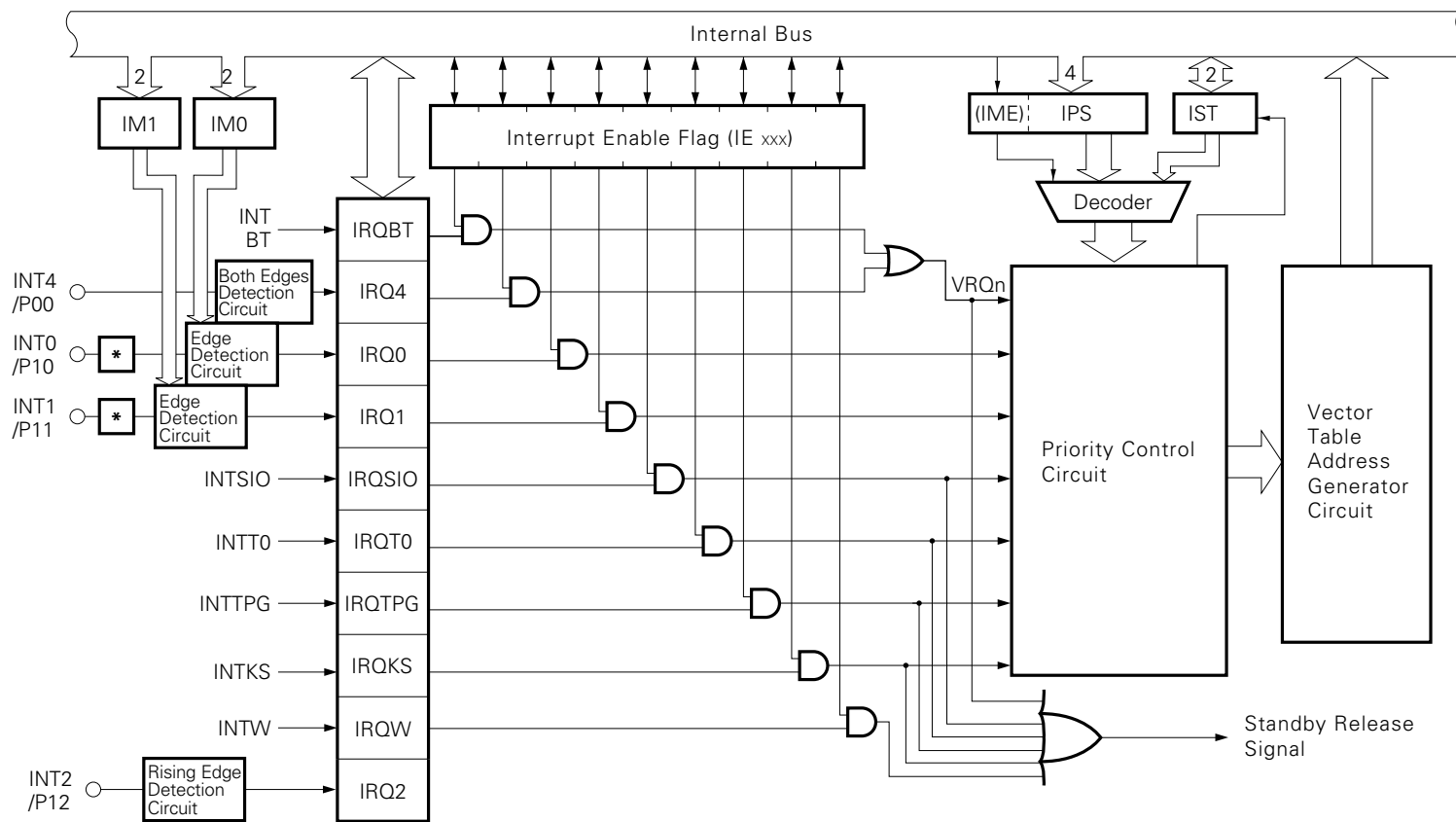

* Noise eliminator

7. STANDBY FUNCTIONS

Two standby modes (STOP mode and HALT mode) are available for the μPD75216A to decrease power consumption in the program standby mode.

Table 7-1 Operation Status in Standby Mode

		STOP Mode	HALT Mode
Set instruction		STOP instruction	HALT instruction
System clock when set		Setting enabled only with main system clock.	Setting enabled with either main system clock or subsystem clock.
Operating State	Clock oscillator	Oscillation stops only with main system clock.	Stops only with CPU clock ϕ (Oscillation continued).
	Basic interval timer	Operation stopped.	Operation (IRQBT set at reference time intervals).
	Serial interface	Operation enabled only when external \overline{SCK} input is selected for serial clock.	Operation enabled when serial clock other than ϕ is specified.
	Timer/event counter	Operation enabled only when TI0 pin input is specified for count clock.	Operation enabled.
	Timer/pulse generator	Operation stopped.	Operation enabled.
	Watch timer	Operation enabled only fXT is selected for count clock.	Operation enabled.
	FIP controller/driver	Operation disabled (display off mode set before disabling).	
	CPU	Operation stopped.	
Release signal		Interrupt request signal (except INT0, INT1, INT2) enabled by interrupt enable flag or \overline{RESET} input.	

8. RESET FUNCTIONS

The reset signal ($\overline{\text{RES}}$) generator has a configuration shown in Fig. 8-1.

Fig. 8-1 Reset Signal Generator

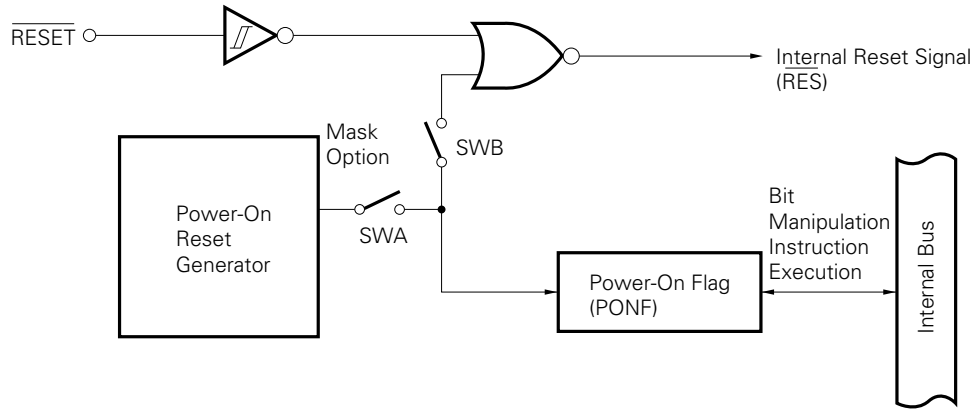

The power-on reset generator is a circuit to generate a one-shot pulse upon detection of the start-up of the power voltage. This pulse is used in the following three ways according to SWA, SWB mask option specification shown in Fig. 8-1. (Refer to **10. MASK OPTION SELECTION**.)

Fig. 8-2 Reset Operation by Power-On Reset

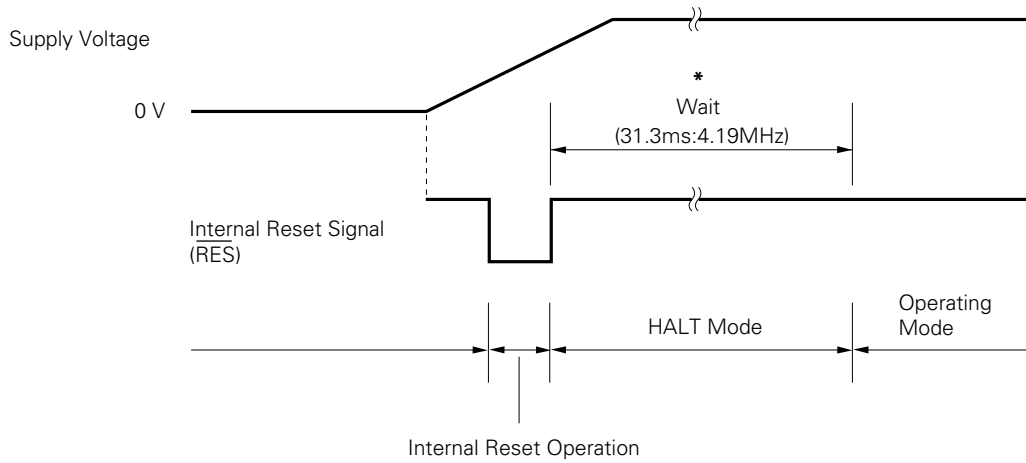

* Wait time does not include a time from $\overline{\text{RES}}$ signal generation to oscillation start.

Fig. 8-3 Reset Operation by $\overline{\text{RESET}}$ Input

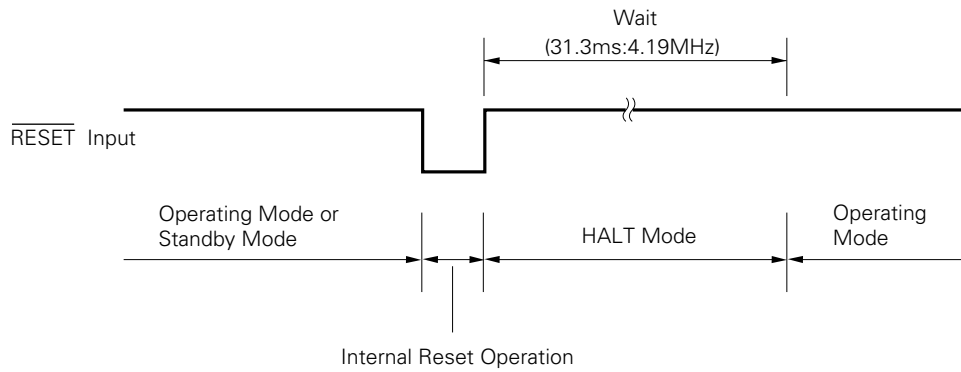

Each hardware state after reset operation is shown in Table 8-1.

Table 8-1 Hardware Statuses after Reset

Hardware		$\overline{\text{RESET}}$ Input in Standby Mode	$\overline{\text{RESET}}$ Input upon Power-on Reset or in Operation
Program counter (PC)		Sets the low-order 6 bits of program memory address 0000H to PC ₁₃₋₈ and the contents of address 0001H to PC ₇₋₀ .	Same as left
PSW	Carry flag (CY)	Hold	Undefined
	Skip flag (SK0 to SK2)	0	0
	Interrupt status flag (IST0, IST1)	0	0
	Bank enable flags (MBE, RBE)	Sets bit 6 of program memory address 0000H to RBE and bit 7 to MBE.	Same as left
Stack pointer (SP)		Undefined	Undefined
Data memory (RAM)		Hold*1	Undefined
General registers (X, A, H, L, D, E, B, C)		Hold	Undefined
Bank select registers (MBS, RBS)		0, 0	0, 0
Basic interval timer	Counter (BT)	Undefined	Undefined
	Mode register (BTM)	0	0
Timer/event counter	Counter (T0)	0	0
	Modulo register (TMOD0)	FFH	FFH
	Mode register (TM0)	0	0
Timer/pulse generator	Modulo register (MODH, MODL)	Hold	Undefined
	Mode register (TPGM)	0	0
Watch timer	Mode register (WM)	0	0
Serial interface	Shift register (SIO)	Hold	Undefined
	Mode register (SIOM)	Only bit 4 set to 1, other bits set to 0	Only bit 4 set to 1, other bits set to 0
Clock generator	Processor clock control register (PCC)	0	0
	System clock control register (SCC)	0	0
Interrupt	Interrupt request flag (IRQ _{xxx})	Reset (0)	Reset (0)
	Interrupt enable flag (IE _{xxx})	0	0
	Priority select register (IPS)	0	0
	INT0 and INT1 mode registers (IM0, IM1)	0, 0	0, 0
Digital port	Output buffer	Off	Off
	Output latch	Clear (0)	Clear (0)
	Input/output mode register (PMGA, PMGB)	0	0
Port H	Output latch	Hold	Undefined
FIP controller/driver	Display mode register (DSPM)	0	0
	Digit select register (DIGS)	1000B	1000B
	Dimmer select register (DIMS)	0	0
	Display data memory	Hold	Undefined
	Output buffer	Off	Off
Power on flag (PONF)		Hold	1 or undefined*2

* 1. Data of data memory addresses 0F8H to 0FDH becomes indeterminate by $\overline{\text{RESET}}$ input.
 2. 1 upon power-on reset, indeterminate after $\overline{\text{RESET}}$ input in operation.

9. INSTRUCTION SET

(1) Operand identifier and description

Enter an operand in the operand column of each instruction using the description method relating to the operand identifier of the instruction (For details, refer to **RA75X Assembler Package User's Manual Language Volume (EEU-730)**). If more than one description method is available, select one. Capital alphabetic letters, plus and minus signs are keywords. Describe them as they are.

In the case of immediate data, describe appropriate numerical values or labels.

Symbols can be described as labels in place of mem, fmem, pmem, bit, etc. (For details, refer to **μPD75216A User's Manual (IEM-988)**). Available labels are limited for fmem and pmem.

Identifier	Description Method
reg reg 1	X, A, B, C, D, E, H, L X, B, C, D, E, H, L
rp rp1 rp2 rp' rp'1	XA, BC, DE, HL BC, DE, HL BC, DE XA, BC, DE, HL, XA', BC', DE', HL' BC, DE, HL, XA', BC', DE', HL'
rpa rpa1	HL, HL+, HL-, DE, DL DE, DL
n4 n8	4-bit immediate data or label 8-bit immediate data or label
mem bit	8-bit immediate data or label* 2-bit immediate data or label
fmem pmem	FB0H to FBFH and FF0H to FFFH immediate data or labels FC0H to FFFH immediate data or labels
addr caddr faddr	0000H to 3F7FH immediate data or labels 12-bit immediate data or label 11-bit immediate data or label
taddr	20H to 7FH immediate data (bit0 = 0) or label
PORTn IExxx RBn MBn	PORT0 to PORT6 IEBT, IESIO, IET0, IETPG, IE0, IE1, IEKS, IEW, IE4 RB0 to RB3 MB0, MB1, MB15

* For 8-bit data processing, only even addresses can be specified.

(2) Legend for operation description

A	: A register; 4-bit accumulator
B	: B register
C	: C register
D	: D register
E	: E register
H	: H register
L	: L register
X	: X register
XA	: Register pair (XA); 8-bit accumulator
BC	: Register pair (BC)
DE	: Register pair (DE)
HL	: Register pair (HL)
XA'	: Expanded register pair (XA')
BC'	: Expanded register pair (BC')
DE'	: Expanded register pair (DE')
HL'	: Expanded register pair (HL')
PC	: Program counter
SP	: Stack pointer
CY	: Carry flag; Bit accumulator
PSW	: Program status word
MBE	: Memory bank enable flag
RBE	: Register bank enable flag
PORT _n	: Port n (n = 0 to 6)
IME	: Interrupt master enable flag
IPS	: Interrupt priority select register
IE _{xxx}	: Interrupt enable flag
RBS	: Register bank select register
MBS	: Memory bank select register
PCC	: Processor clock control register
•	: Address and bit delimiter
(xx)	: Contents addressed by xx
xxH	: Hexadecimal data

(3) Description of symbols in the addressing area column

* 1	MB = MBE · MBS (MBS = 0, 1, 15)	Data Memory Addressing
* 2	MB = 0	
* 3	MBE = 0 : MB = 0 (00H to 7FH) MB = 15 (80H to FFH) MBE = 1 : MB = MBS (MBS = 0, 1, 15)	
* 4	MB = 15, fmem = FB0H to FBFH, FF0H to FFFH	
* 5	MB = 15, pmem = FC0H to FFFH	
* 6	addr = 0000H to 3F7FH	Program Memory Addressing
* 7	addr = (Current PC) - 15 to (Current PC) - 1, (Current PC) + 2 to (Current PC) + 16	
* 8	caddr = 0000H to 0FFFH (PC _{13,12} = 00B) or 1000H to 1FFFH (PC _{13,12} = 01B) or 2000H to 2FFFH (PC _{13,12} = 10B) or 3000H to 3F7FH (PC _{13,12} = 11B)	
* 9	faddr = 0000H to 07FFH	
* 10	taddr = 0020H to 007FH	

- Remarks**
1. MB indicates accessible memory bank.
 2. In *2, MB = 0 irrespective of MBE and MBS.
 3. In *4 and *5, MB = 15 irrespective of MBE and MBS.
 4. *6 to *10 indicate addressable areas.

(4) Description of the machine cycle column

S indicates the number of machine cycles required for skip operation by an instruction having skip function.

The S value varies as follows:

- When not skipped S = 0
- When 1-byte or 2-byte instructions are skipped S = 1
- When 3-byte instructions are skipped (BR !addr, CALL !addr instruction) S = 2

Note GETI instruction is skipped in one machine cycle.

One machine cycle is equal to one cycle(=tcv) of CPU clock Φ and three time periods are available according to PCC setting.

Note 1	Mnemonic	Operands	No. of Bytes	Machine Cycle	Operation	Addressing Area	Skip Condition
Transfer	MOV	A, #n4	1	1	A←n4		Stack A
		reg1, #n4	2	2	reg1←n4		
		XA, #n8	2	2	XA←n8		Stack A
		HL, #n8	2	2	HL←n8		Stack B
		rp2, #n8	2	2	rp2←n8		
		A, @HL	1	1	A←(HL)	*1	
		A, @HL+	1	2 + S	A←(HL), then L←L+1	*1	L = 0
		A, @HL-	1	2 + S	A←(HL), then L←L-1	*1	L = FH
		A, @rpa1	1	1	A←(rpa1)	*2	
		XA, @HL	2	2	XA←(HL)	*1	
		@HL, A	1	1	(HL)←A	*1	
		@HL, XA	2	2	(HL)←XA	*1	
		A, mem	2	2	A←(mem)	*3	
		XA, mem	2	2	XA←(mem)	*3	
		mem, A	2	2	(mem)←A	*3	
		mem, XA	2	2	(mem)←XA	*3	
		A, reg	2	2	A←reg		
		XA, rp'	2	2	XA←rp'		
	reg1, A	2	2	reg1←A			
	rp'1, XA	2	2	rp'1←XA			
	XCH	A, @HL	1	1	A↔(HL)	*1	
		A, @HL+	1	2 + S	A↔(HL), then L←L+1	*1	L = 0
		A, @HL-	1	2 + S	A↔(HL), then L←L-1	*1	L = FH
		A, @rpa1	1	1	A↔(rpa1)	*2	
		XA, @HL	2	2	XA↔(HL)	*1	
		A, mem	2	2	A↔(mem)	*3	
		XA, mem	2	2	XA↔(mem)	*3	
A, reg1		1	1	A↔reg1			
XA, rp'		2	2	XA↔rp'			
Note 2	MOVT	XA, @PCDE	1	3	XA←(PC ₁₃₋₈ +DE) _{ROM}		
		XA, @PCXA	1	3	XA←(PC ₁₃₋₈ +XA) _{ROM}		

- Note** 1. Instruction Group
 2. Table reference

Note	Mnemonic	Operand	No. of Bytes	Machine Cycle	Operation	Addressing Area	Skip Condition
Bit transfer	MOV1	CY, fmem.bit	2	2	$CY \leftarrow (\text{fmem.bit})$	*4	
		CY, pmem.@L	2	2	$CY \leftarrow (\text{pmem}_{7-2} + L_{3-2}.\text{bit}(L_{1-0}))$	*5	
		CY, @H+mem.bit	2	2	$CY \leftarrow (\text{H} + \text{mem}_{3-0}.\text{bit})$	*1	
		fmem.bit, CY	2	2	$(\text{fmem.bit}) \leftarrow CY$	*4	
		pmem.@L, CY	2	2	$(\text{pmem}_{7-2} + L_{3-2}.\text{bit}(L_{1-0})) \leftarrow CY$	*5	
		@H+mem.bit, CY	2	2	$(\text{H} + \text{mem}_{3-0}.\text{bit}) \leftarrow CY$	*1	
Operation	ADDS	A, #n4	1	1 + S	$A \leftarrow A + n4$		carry
		XA, #n8	2	2 + S	$XA \leftarrow XA + n8$		carry
		A, @HL	1	1 + S	$A \leftarrow A + (\text{HL})$	*1	carry
		XA, rp'	2	2 + S	$XA \leftarrow XA + rp'$		carry
		rp'1, XA	2	2 + S	$rp'1 \leftarrow rp'1 + XA$		carry
	ADDC	A, @HL	1	1	$A, CY \leftarrow A + (\text{HL}) + CY$	*1	
		XA, rp'	2	2	$XA, CY \leftarrow XA + rp' + CY$		
		rp'1, XA	2	2	$rp'1, CY \leftarrow rp'1 + XA + CY$		
	SUBS	A, @HL	1	1 + S	$A \leftarrow A - (\text{HL})$	*1	borrow
		XA, rp'	2	2 + S	$XA \leftarrow XA - rp'$		borrow
		rp'1, XA	2	2 + S	$rp'1 \leftarrow rp'1 - XA$		borrow
	SUBC	A, @HL	1	1	$A, CY \leftarrow A - (\text{HL}) - CY$	*1	
		XA, rp'	2	2	$XA, CY \leftarrow XA - rp' - CY$		
		rp'1, XA	2	2	$rp'1, CY \leftarrow rp'1 - XA - CY$		
	AND	A, #n4	2	2	$A \leftarrow A \wedge n4$		
		A, @HL	1	1	$A \leftarrow A \wedge (\text{HL})$	*1	
		XA, rp'	2	2	$XA \leftarrow XA \wedge rp'$		
		rp'1, XA	2	2	$rp'1 \leftarrow rp'1 \wedge XA$		
	OR	A, #n4	2	2	$A \leftarrow A \vee n4$		
		A, @HL	1	1	$A \leftarrow A \vee (\text{HL})$	*1	
		XA, rp'	2	2	$XA \leftarrow XA \vee rp'$		
		rp'1, XA	2	2	$rp'1 \leftarrow rp'1 \vee XA$		
	XOR	A, #n4	2	2	$A \leftarrow A \veebar n4$		
		A, @HL	1	1	$A \leftarrow A \veebar (\text{HL})$	*1	
XA, rp'		2	2	$XA \leftarrow XA \veebar rp'$			
rp'1, XA		2	2	$rp'1 \leftarrow rp'1 \veebar XA$			

Note Instruction Group

Note 1	Mnemonic	Operands	No. of Bytes	Machine Cycle	Operation	Addressing Area	Skip Condition
Note 2	RORC	A	1	1	$CY \leftarrow A_0, A_3 \leftarrow CY, A_{n-1} \leftarrow A_n$		
	NOT	A	2	2	$A \leftarrow \bar{A}$		
Increment/decrement	INCS	reg	1	1 + S	$reg \leftarrow reg + 1$		reg = 0
		rp1	1	1 + S	$rp1 \leftarrow rp1 + 1$		rp1 = 00H
		@HL	2	2 + S	$(HL) \leftarrow (HL) + 1$	*1	(HL) = 0
		mem	2	2 + S	$(mem) \leftarrow (mem) + 1$	*3	(mem) = 0
	DECS	reg	1	1 + S	$reg \leftarrow reg - 1$		reg = FH
		rp'	2	2 + S	$rp' \leftarrow rp' - 1$		rp = FFH
Compare	SKE	reg, #n4	2	2 + S	Skip if reg = n4		reg = n4
		@HL, #n4	2	2 + S	Skip if (HL) = n4	*1	(HL) = n4
		A, @HL	1	1 + S	Skip if A = (HL)	*1	A = (HL)
		XA, @HL	2	2 + S	Skip if XA = (HL)	*1	XA = (HL)
		A, reg	2	2 + S	Skip if A = reg		A = reg
		XA, rp'	2	2 + S	Skip if XA = rp'		XA = rp'
Carry flag manipulation	SET1	CY	1	1	$CY \leftarrow 1$		
	CLR1	CY	1	1	$CY \leftarrow 0$		
	SKT	CY	1	1 + S	Skip if CY = 1		CY = 1
	NOT1	CY	1	1	$CY \leftarrow \overline{CY}$		

- Note**
1. Instruction Group
 2. Accumulator manipulation

Note	Mnemonic	Operands	No. of Bytes	Machine Cycle	Operation	Addressing Area	Skip Condition
Memory bit manipulation	SET1	mem.bit	2	2	(mem.bit)←1	*3	
		fmem.bit	2	2	(fmem.bit)←1	*4	
		pmem.@L	2	2	(pmem ₇₋₂ +L ₃₋₂ .bit(L ₁₋₀))←1	*5	
		@H + mem.bit	2	2	(H+mem ₃₋₀ .bit)←1	*1	
	CLR1	mem.bit	2	2	(mem.bit)←0	*3	
		fmem.bit	2	2	(fmem.bit)←0	*4	
		pmem.@L	2	2	(pmem ₇₋₂ +L ₃₋₂ .bit(L ₁₋₀))←0	*5	
		@H+mem.bit	2	2	(H+mem ₃₋₀ .bit)←0	*1	
	SKT	mem.bit	2	2 + S	Skip if (mem.bit) = 1	*3	(mem.bit) = 1
		fmem.bit	2	2 + S	Skip if (fmem.bit) = 1	*4	(fmem.bit) = 1
		pmem.@L	2	2 + S	Skip if (pmem ₇₋₂ +L ₃₋₂ .bit(L ₁₋₀)) = 1	*5	(pmem.@L) = 1
		@H+mem.bit	2	2 + S	Skip if (H+mem ₃₋₀ .bit) = 1	*1	(@H+mem.bit) = 1
	SKF	mem.bit	2	2 + S	Skip if (mem.bit) = 0	*3	(mem.bit) = 0
		fmem.bit	2	2 + S	Skip if (fmem.bit) = 0	*4	(fmem.bit) = 0
		pmem.@L	2	2 + S	Skip if (pmem ₇₋₂ +L ₃₋₂ .bit(L ₁₋₀)) = 0	*5	(pmem.@L) = 0
		@H+mem.bit	2	2 + S	Skip if (H+mem ₃₋₀ .bit) = 0	*1	(@H+mem.bit) = 0
	SKTCLR	fmem.bit	2	2 + S	Skip if (fmem.bit) = 1 and clear	*4	(fmem.bit) = 1
		pmem.@L	2	2 + S	Skip if (pmem ₇₋₂ +L ₃₋₂ .bit(L ₁₋₀))=1 and clear	*5	(pmem.@L) = 1
		@H+mem.bit	2	2 + S	Skip if (H+mem ₃₋₀ .bit)=1 and clear	*1	(@H+mem.bit)=1
	AND1	CY, fmem.bit	2	2	CY←CY∧(fmem.bit)	*4	
		CY, pmem.@L	2	2	CY←CY∧(pmem ₇₋₂ +L ₃₋₂ .bit(L ₁₋₀))	*5	
		CY, @H+mem.bit	2	2	CY←CY∧(H+mem ₃₋₀ .bit)	*1	
	OR1	CY, fmem.bit	2	2	CY←CY∨(fmem.bit)	*4	
		CY, pmem.@L	2	2	CY←CY∨(pmem ₇₋₂ +L ₃₋₂ .bit(L ₁₋₀))	*5	
CY, @H+mem.bit		2	2	CY←CY∨(H+mem ₃₋₀ .bit)	*1		
XOR1	CY, fmem.bit	2	2	CY←CY⊕(fmem.bit)	*4		
	CY, pmem.@L	2	2	CY←CY⊕(pmem ₇₋₂ +L ₃₋₂ .bit(L ₁₋₀))	*5		
	CY, @H+mem.bit	2	2	CY←CY⊕(H+mem ₃₋₀ .bit)	*1		
Branch	BR	addr	—	—	PC ₁₃₋₀ ←addr (Optimum instruction is selected from among BR !addr, BRCB !caddr and BR \$addr by an assembler.)	*6	
		!addr	3	3	PC ₁₃₋₀ ←addr	*6	
		\$addr	1	2	PC ₁₃₋₀ ←addr	*7	
	BRCB	!caddr	2	2	PC ₁₃₋₀ ←PC _{13,12} +caddr ₁₁₋₀	*8	
	BR	PCDE	2	3	PC ₁₃₋₀ ←PC ₁₃₋₈ +DE		
PCXA		2	3	PC ₁₃₋₀ ←PC ₁₃₋₈ +XA			

Note Instruction Group

Note	Mnemonic	Operands	No. of Bytes	Machine Cycle	Operation	Addressing Area	Skip Condition
Subroutine stack control	CALL	laddr	3	3	(SP-4) (SP-1) (SP-2)←PC ₁₁₋₀ (SP-3)← MBE, RBE, PC _{13, 12} PC ₁₃₋₀ ←addr, SP←SP-4	*6	
	CALLF	lfaddr	2	2	(SP-4) (SP-1) (SP-2)←PC ₁₁₋₀ (SP-3)← MBE, RBE, PC _{13, 12} PC ₁₃₋₀ ←000, faddr, SP←SP-4	*9	
	RET		1	3	MBE, RBE, PC _{13, 12} ←(SP+1) PC ₁₁₋₀ ←(SP) (SP+3) (SP+2) SP←SP+4		
	RETS		1	3 + S	MBE, RBE, PC _{13, 12} ←(SP+1) PC ₁₁₋₀ ←(SP) (SP+3) (SP+2) SP←SP+4 then skip unconditionally		Unconditional
	RETI		1	3	×, ×, PC _{13, 12} ←(SP+1) PC ₁₁₋₀ ←(SP) (SP+3) (SP+2) PSW←(SP+4) (SP+5), SP←SP+6		
		PUSH	rp	1	1	(SP-1) (SP-2)←rp, SP←SP-2	
		BS	2	2	(SP-1)←MBS, (SP-2)←RBS, SP←SP-2		
	POP	rp	1	1	rp←(SP+1) (SP), SP←SP+2		
BS		2	2	MBS←(SP+1), RBS←(SP), SP←SP+2			
Interrupt control	EI		2	2	IME (IPS.3)←1		
		IE _{xxx}	2	2	IE _{xxx} ←1		
	DI		2	2	IME (IPS.3)←0		
		IE _{xxx}	2	2	IE _{xxx} ←0		
Input/output	IN *	A, PORT _n	2	2	A←PORT _n (n = 0 to 6)		
		XA, PORT _n	2	2	XA←PORT _{n+1} , PORT _n (n = 4)		
	OUT *	PORT _n , A	2	2	PORT _n ←A (n = 2 to 6)		
		PORT _n , XA	2	2	PORT _{n+1} , PORT _n ←XA (n = 4)		
CPU control	HALT		2	2	Set HALT Mode (PCC.2←1)		
	STOP		2	2	Set STOP Mode (PCC.3←1)		
	NOP		1	1	No Operation		
Special	SEL	RB _n	2	2	RBS←n (n = 0 to 3)		
		MB _n	2	2	MBS←n (n = 0, 1, 15)	*10	

* MBE = 0 or MBE = 1 and MBS = 15 must be set for execution of IN/OUT instruction.

Note Instruction Group

Note	Mnemonic	Operands	No. of Bytes	Machine Cycle	Operation	Addressing Area	Skip Condition
Special	GETI *	taddr	1	3	• TBR instruction PC ₁₃₋₀ ←(taddr) ₄₋₀ +(taddr+1)	*10	
					• TCALL instruction (SP-4)(SP-1)(SP-2)←PC ₁₁₋₀ (SP-3)← MBE, RBE, PC _{13, 12} PC ₁₃₋₀ ←(taddr) ₄₋₀ +(taddr+1) SP←SP-4		
					• (taddr) (taddr+1) instruction executed in the case of instruction except TBR and TCALL instructions		Depends on instructions referred to.

* TBR and TCALL instructions are assembled pseudo-instructions to define the GETI instruction table.

Note Instruction Group

10. MASK OPTION SELECTION

The μPD75216A has the following mask options enabling or disabling on-chip components.

(1) Pin

Pin	Mask Option
P60 to P63	Pull-up resistor incorporation enabled bit-wise
T0/T9	
T10/S15/PH3 to T13/S12/PH0	
T14/S11, T15/S10	
S0 to S9	
XT1, XT2	Deletion of subsystem clock oscillator feedback resistor possible

- Note**
1. In a system not using subsystem clocks, power consumption in the STOP mode can be decreased by removing the feedback resistor from the oscillator.
 2. The feedback resistor must be incorporated when using subsystem clock.

(2) Power-on reset generator, power-on flag (PONF)

One of the following three can be selected.

Switch Selection (See Fig. 8-1)		Power-On Reset Generator	Power-On Flag (PONF)	Internal Reset Signal ($\overline{\text{RES}}$)
SWA	SWB			
ON	ON	Incorporated	Incorporated	Generate automatically
ON	OFF	Incorporated	Incorporated	Not generate automatically
OFF	OFF	Not incorporated	Not incorporated	—

11. APPLICATION BLOCK DIAGRAM

11.1 VCR TIMER TUNER

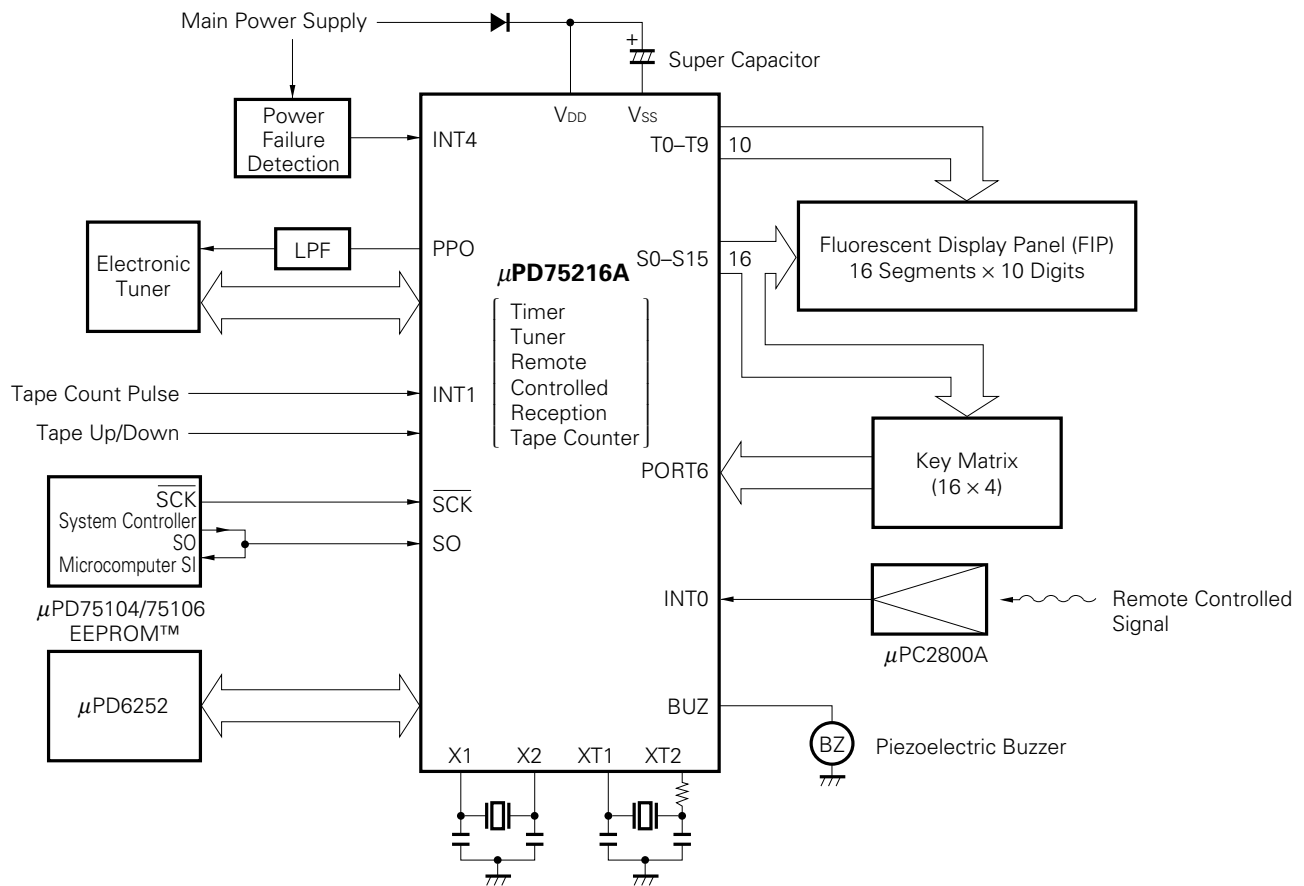

11.2 CD PLAYER

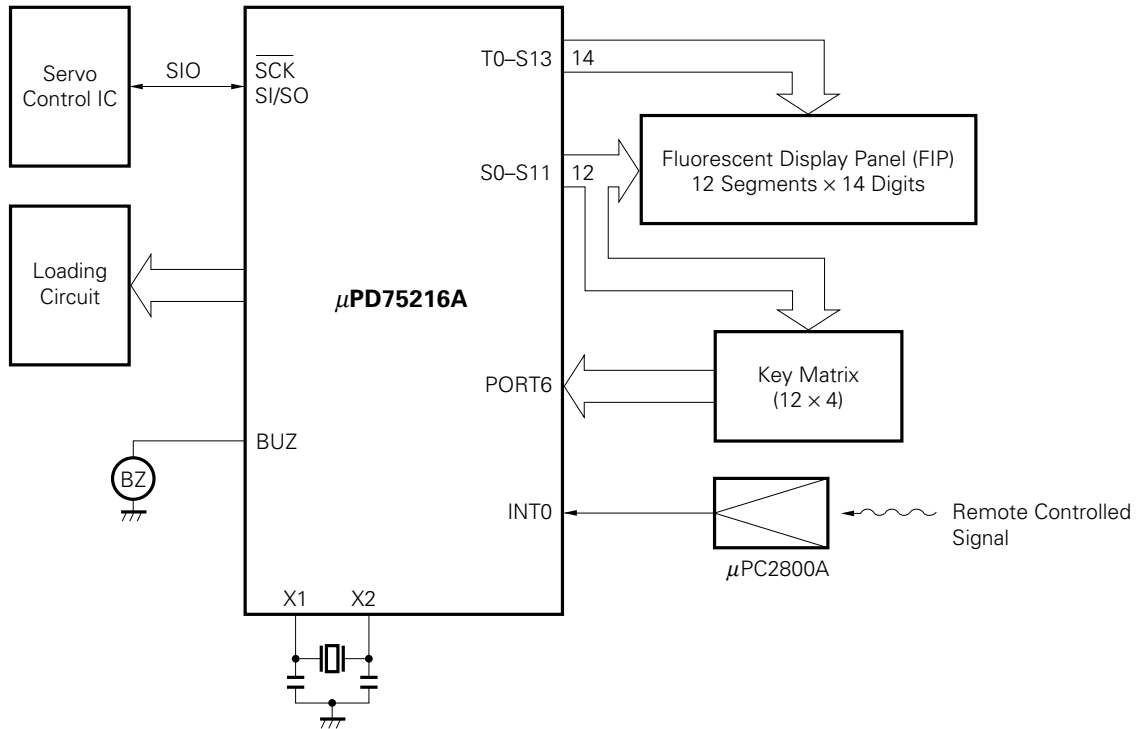

11.3 ECR

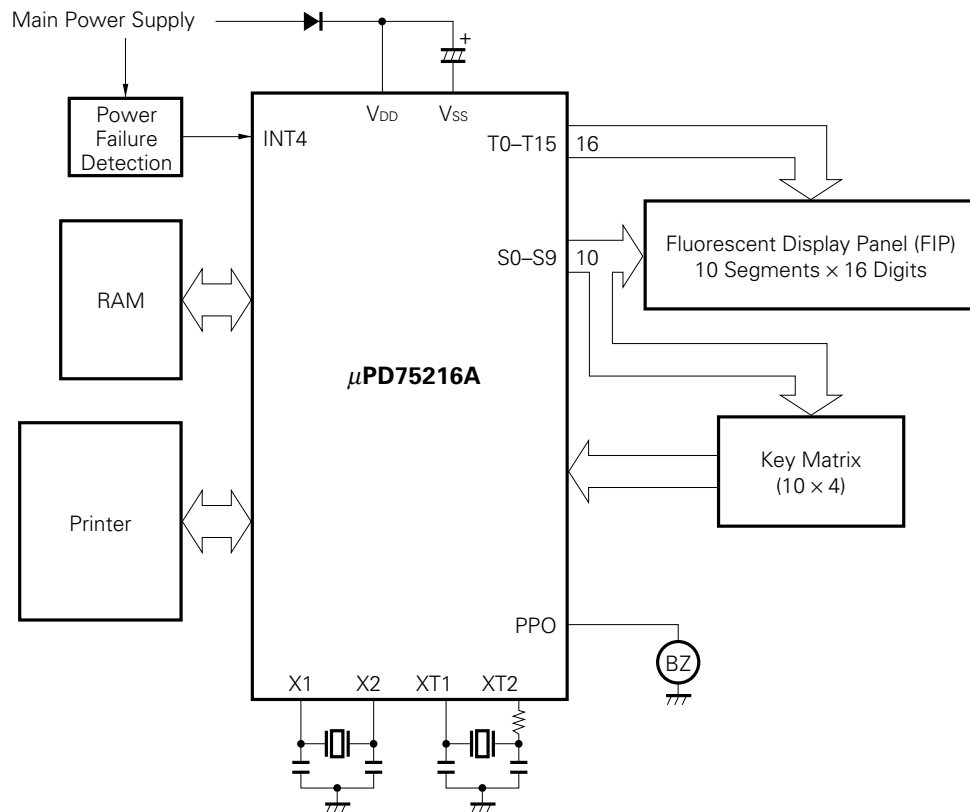

12. ELECTRICAL SPECIFICATIONS

ABSOLUTE MAXIMUM RATINGS (Ta = 25 °C)

PARAMETER	SYMBOL	TEST CONDITIONS	RATING	UNIT
Power supply voltage	V _{DD}		-0.3 to +7.0	V
	V _{LOAD}		V _{DD} -40 to V _{DD} +0.3	V
	V _{PRE}		V _{DD} -12 to V _{DD} +0.3	V
Input voltage	V _I		-0.3 to V _{DD} +0.3	V
Output voltage	V _O	Pins except display output pins	-0.3 to V _{DD} +0.3	V
	V _{OD}	Display output pins	V _{DD} -40 to V _{DD} +0.3	V
Output current high	I _{OH}	1 pin except display output pins	-15	mA
		S0 to S9 1 pin	-15	mA
		T0 to T15 1 pin	-30	mA
		Total of pins except display output pins	-20	mA
		Total of display output pins	-120	mA
Output current low	I _{OL}	1 pin	17	mA
		Total of pins	60	mA
Total loss*1	P _T	Plastic QFP	450	mW
		Plastic shrink DIP	600	mW
Operating temperature	T _{opt}		-40 to +85	°C
Storage temperature	T _{stg}		-65 to +150	°C

★ **Note** Product quality may suffer if the absolute maximum rating is exceeded for even a single parameter, or even momentarily. In other words, the absolute maximum ratings are rated values at which the product is on the verge of suffering physical damage, and therefore, the product must be used under conditions which ensure that the absolute maximum ratings are not exceeded.

OPERATING VOLTAGE (Ta = -40 to +85 °C)

PARAMETER	TEST CONDITIONS	MIN.	MAX.	UNIT
CPU *2		*3	6.0	V
Display controller		4.5	6.0	V
Time/pulse generator		4.5	6.0	V
Other hardware *2		2.7	6.0	V

CAPACITANCE (Ta = 25 °C, V_{DD} = 0 V)

PARAMETER	SYMBOL	TEST CONDITIONS	MIN.	TYP.	MAX.	UNIT	
Input capacitance	C _{IN}	f = 1 MHz Unmeasured pin returned to 0 V			15	pF	
Output capacitance	Except display output		C _{OUT}			15	pF
	Display output					35	pF
Input /output capacitance	C _{IO}					15	pF

* 1. Calculation of total loss

Design so that the sum of the following three power consumption values for the μPD75216ACW/GF will be less than the total loss P_T (It is recommended to use the system with 80 % or less of the rating).

- ① CPU loss : Given as $V_{DD} (MAX.) \times I_{DD1} (MAX.)$
- ② Output pin loss : There are normal output pin loss and display output pin loss. It is necessary to add a loss derived from the flow of maximum current to each output pin.
- ③ Pull-down register loss : Power loss due to a pull-down resistor incorporated in the display output pin by mask option.

Example Suppose 4-LED output with $9_{SEG} \times 11_{DIGIT}$, $V_{DD} = 5 V + 10 \%$ and 4.19 MHz oscillation and let a current of 3 mA, 15 mA and up to 10 mA flow to the segment pin, timing pin and LED output pin, respectively. Further, let the voltage of fluorescent display tube (V_{LOAD} voltage) be $-30 V$ and normal voltage be small.

- ① CPU loss : $5.5 V \times 9.0 mA = 49.5 mW$
- ② Pin loss : Segment pin $2V \times 3 mA \times 9 = 54 mW$
 Timing pin $2V \times 15 mA = 30 mW$
 LED output $\left(\frac{10}{15} \times 2 V\right) \times 10 mA \times 4 = 53 mW$
- ③ Pull-down resistor loss $\frac{(30 + 5.5V)^2}{25 k\Omega} \times 10 = 504.1 mW$

$$P_T = ① + ② + ③ = 690.6 mW$$

In this example, since the allowable total loss is 600 mW for the shrink DIP package, it is necessary to decrease power consumption by decreasing the number of on-chip pull-down resistors. In this example, power consumption can be adjusted to 577.8 mW by incorporating pull-down resistors in only 11 digit ★ outputs and 7 segment outputs and externally mounting pull-down resistors to the 2 remaining segment outputs.

- 2. Except the system clock oscillator, display controller and timer/pulse generator.
- 3. The operating voltage range varies depending on the cycle time. Refer to the section describing AC characteristics.

MAIN SYSTEM CLOCK OSCILLATOR CHARACTERISTICS (Ta = -40 to +85 °C, VDD = 2.7 to 6.0 V)

RESONATOR	RECOMMENDED CIRCUIT	PARAMETER	TEST CONDITIONS	MIN.	TYP.	MAX.	UNIT
Ceramic resonator*1		Oscillator frequency (f _{xx}) *2	V _{DD} = Oscillation voltage range	2.0		5.0	MHz
		Oscillation stabilization time *3	After V _{DD} reaches the minimum value in the oscillation voltage range			4	ms
Crystal resonator*1		Oscillator frequency (f _{xx}) *2		2.0	4.19	5.0 *4	MHz
		Oscillation stabilization time *3	V _{DD} = 4.5 to 6.0 V			10	ms
External clock		X1 input frequency (f _x) *2		2.0		5.0	MHz
		X1 input high and low level widths (t _{xH} , t _{xL})		100		250	ns

- * 1. Refer to **RECOMMENDED OSCILLATOR CONSTANTS**.
2. Oscillator characteristics only. Refer to the description of AC characteristics for details of instruction execution time.
3. Time required for oscillation to become stabilized after V_{DD} reaches the minimum value in the oscillation voltage range or STOP mode release.
4. When oscillator frequency is "4.19 < f_{xx} ≤ 5.0 MHz", do not select "PCC = 0011" as instruction execution time. If "PCC = 0011" is selected, 1 machine cycle becomes less than 0.95 μs, with the result that the specified MIN. value of 0.95 μs cannot be observed.

★ **Note** When the main system clock oscillator is used, the following should be noted concerning wiring in the area in the figure enclosed by a dotted line to prevent the influence of wiring capacitance, etc.

- The wiring should be kept as short as possible.
- No other signal lines should be crossed. Keep away from lines carrying a high fluctuating current.
- The oscillator capacitor grounding point should always be at the same potential as V_{SS}. Do not connect to a ground pattern carrying a high current.
- A signal should not be taken from the oscillator.

SUBSYSTEM CLOCK OSCILLATOR CHARACTERISTICS (Ta = -40 to +85 °C, VDD = 2.7 to 6.0 V)

RESONATOR	RECOMMENDED CIRCUIT	PARAMETER	TEST CONDITIONS	MIN.	TYP.	MAX.	UNIT
Crystal resonator*1		Oscillator frequency (f _{XT}) *2		32	32.768	35	kHz
		Oscillation stabilization time *3	V _{DD} = 4.5 to 6.0 V		1.0	2	s
						10	s
External clock		XT1 input frequency (f _{XT})		32		100	kHz
		XT1 input high and low level widths (t _{XTH} , t _{XTL})		10		32	μs

- * 1. Recommended resonators are shown in following page.
- 2. Oscillator characteristics only. Refer to the description of AC characteristics for instruction execution time.
- 3. Oscillation stabilization time is a time required for oscillation to become stabilized after V_{DD} reaches the minimum value in the oscillation voltage range.

Note When the subsystem clock oscillator is used, the following should be noted concerning wiring in the area in the figure enclosed by a dotted line to prevent the influence of wiring capacitance, etc. ★

- The wiring should be kept as short as possible.
- No other signal lines should be crossed. Keep away from lines carrying a high fluctuating current.
- The oscillator capacitor grounding point should always be at the same potential as V_{SS}. Do not connect to a ground pattern carrying a high current.
- A signal should not be taken from the oscillator.

The subsystem clock oscillator is a low-amplitude circuit in order to achieve a low consumption current, and is more prone to misoperation due to noise than the main system clock oscillator. Particular care is therefore required with the wiring method when the subsystem clock is used.

RECOMMENDED OSCILLATOR CONSTANTS

MAIN SYSTEM CLOCK : CERAMIC OSCILLATOR (Ta = -40 to +85 °C)

MANUFACTURER	PRODUCT NAME	EXTERNAL CAPACITANCE (pF)		OSCILLATION VOLTAGE RANGE (V)		REMARKS
		C1	C2	MIN.	MAX.	
Murata Mfg. Co., Ltd.	CSA 2.00MG	30	30	4.0	6.0	On-chip C type
	CSA 4.19MG					
	CSA 4.91MG					
	CST 2.00MG	Not required	Not required			
	CST 4.19MG					
	CST 4.91MG					
Kyocera Corp.	KBR-2.0MS	47	47	4.0	6.0	
	KBR-4.0MS					
	KBR-4.19MS	33	33			
	KBR-4.19MS					
TDK	FCR 3.58M2	30	30	4.0	6.0	On-chip C type
	FCR 4.00M2					
	FCR 4.19M2					
	FCR 4.19MC	Not required	Not required			

MAIN SYSTEM CLOCK : CRYSTAL RESONATOR (Ta = -40 to +85 °C)

MANUFACTURER	FREQUENCY (MHz)	HOLDER	LOAD CAPACITANCE CL (pF)	EXTERNAL CAPACITANCE (pF)		OSCILLATION VOLTAGE RANGE (V)		REMARKS
				C1	C2	MIN.	MAX.	
Kinseki	2.00	HC-18/U	16	20	20	4.0	6.0	
	4.19	HC-49/U						
	4.91	HC-43/U						

Note Carry out fine adjustment of crystal oscillator frequency on the external capacitance C1.

SUBSYSTEM CLOCK : 32.768 kHz CRYSTAL RESONATOR (Ta = -10 to +60 °C)

MANUFACTURER	MODEL NAME	LOAD CAPACITANCE CL (pF)	EXTERNAL CAPACITANCE (pF)			OSCILLATION VOLTAGE RANGE (V)		REMARKS
			C3 (pF)	C4 (pF)	R (kΩ)	MIN. (V)	MAX. (V)	
Kinseki	P-3	12	22	22	330	2.7	6.0	
Citizen Watch Co.	CFS-308	14	22	33	330			

Note Carry out fine adjustment of crystal oscillator frequency on the external capacitance C3.

DC CHARACTERISTICS (Ta = -40 to 85 °C, VDD = 2.7 to 6.0 V)

PARAMETER	SYMBOL	TEST CONDITIONS		MIN.	TYP.	MAX.	UNIT	
Input voltage high	V _{IH1}	Except below		0.7 V _{DD}		V _{DD}	V	
	V _{IH2}	Ports 0, 1, RESET		0.75 V _{DD}		V _{DD}	V	
	V _{IH3}	X1, X2, XT1		V _{DD} -0.4		V _{DD}	V	
	V _{IH4}	Port 6	V _{DD} = 4.5 to 6.0 V		0.65 V _{DD}		V _{DD}	V
			0.7 V _{DD}		V _{DD}	V		
Input Voltage low	V _{IL1}	Except below		0		0.3 V _{DD}	V	
	V _{IL2}	Ports 0, 1, 6, RESET		0		0.2 V _{DD}	V	
	V _{IL3}	X1, X2, XT1		0		0.4	V	
Output voltage high	V _{OH}	All output pins	V _{DD} = 4.5 to 6.0V, I _{OH} = -1 mA	V _{DD} -1.0			V	
			I _{OH} = -100 μA	V _{DD} -0.5			V	
Output voltage low	V _{OL}	Ports 4, 5	V _{DD} = 4.5 to 6.0V, I _{OL} = 15 mA		0.4	2.0	V	
		All output pins	V _{DD} = 4.5 to 6.0V, I _{OL} = 1.6 mA			0.4	V	
			I _{OL} = 400 μA			0.5	V	
Input leakage current high	I _{LIH1}	Except X1,X2,XT1	V _{IN} = V _{DD}			3	μA	
	I _{LIH2}	X1, X2, XT1				20	μA	
Input leakage current low	I _{LIL1}	Except X1,X2,XT1	V _{IN} = 0 V			-3	μA	
	I _{LIL2}	X1, X2, XT1				-20	μA	
Output leakage current high	I _{LOH}	All output pins	V _{OUT} = V _{DD}			3	μA	
Output leakage current low	I _{LOL1}	Except display output	V _{OUT} = 0 V			-3	μA	
	I _{LOL2}	Display output	V _{OUT} = V _{LOAD} = V _{DD} - 35 V			-10	μA	
Display output current	I _{OD}	S0 to S9	V _{DD} = 4.5 to 6.0 V	V _{PRE} = V _{DD} - 9 ± 1 V*1	-3	-5.5	mA	
			V _{PRE} = 0 V	-1.5	-3.5	mA		
		T0 to T15	V _{OD} = V _{DD} - 2 V	V _{PRE} = V _{DD} - 9 ± 1 V*1	-15	-22	mA	
			V _{PRE} = 0 V	-7	-15	mA		
Built-in pull-down resistor (mask option)	R _{P6}	Port 6 V _{IN} = V _{DD}	V _{DD} = 4.5 to 6.0 V		20	80	200	kΩ
					20		1000	kΩ
	R _L	Display output	V _{OD} - V _{LOAD} = 35 V		25	70	135	kΩ
Supply current*2	I _{DD1}	4.19 MHz crystal oscillation C1 = C2 = 15pF	V _{DD} = 5 V ± 10 %*3			3.0	9.0	mA
			V _{DD} = 3 V ± 10 %*4			0.55	1.5	mA
	I _{DD2}	HALT mode	V _{DD} = 5 V ± 10 %			600	1800	μA
			V _{DD} = 3 V ± 10 %			200	600	μA
	I _{DD3}	32 kHz crystal oscillation*5	V _{DD} = 3 V ± 10 %			40	120	μA
	I _{DD4}		HALT mode	V _{DD} = 3 V ± 10 %			5	15
I _{DD5}	XT1 = 0 V STOP mode	V _{DD} = 5 V ± 10 %			0.5	20	μA	
		V _{DD} = 3 V ± 10 %			0.1	10	μA	

* 1. The following external circuit is recommended.

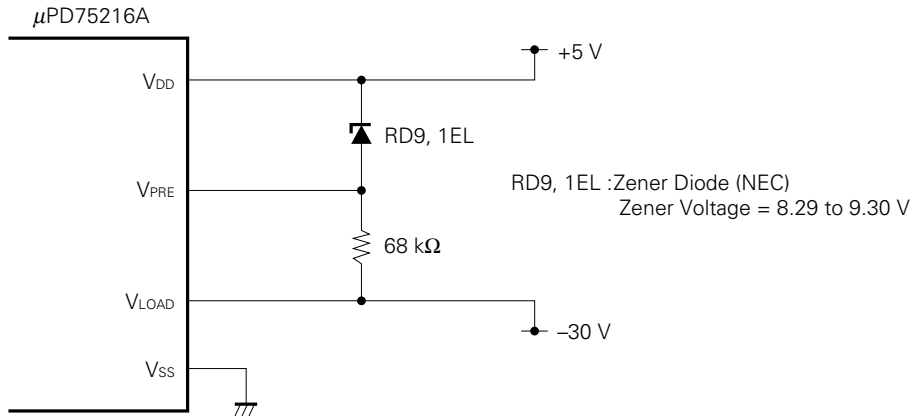

- 2. Current to the on-chip pull-down resistor and power-on reset circuit (mask option) is not included.
- 3. When the processor clock control register (PCC) is set to 0011 and is operated in the high-speed mode.
- 4. When the PCC register is set to 0000 and is operated in the low-speed mode.
- 5. When the system clock control register (SCC) is set to 1001 and is operated with the subsystem clock with main system clock oscillation stopped.

POWER-ON RESET CIRCUIT CHARACTERISTICS (MASK OPTION) (Ta = -40 to +85 °C)

PARAMETER	SYMBOL	TEST CONDITIONS	MIN.	TYP.	MAX.	UNIT
Power-on reset operating voltage high	V _{DDH}		4.5		6.0	V
Power-on reset operating voltage low	V _{DDL}		0		0.2	V
Power supply voltage rise time	t _r		10		*1	μs
Power supply voltage off time	t _{off}		1			s
Power-on reset circuit*2 current consumption	I _{DDPR}	V _{DD} = 5 V ± 10 %		10	100	μA
		V _{DD} = 2.7 V		2	20	μA

- * 1. 2¹⁷/f_{XX} (31.3 ms at f_{XX} = 4.19 MHz)
- 2. Current with on-chip power-on reset circuit or power-on flag.

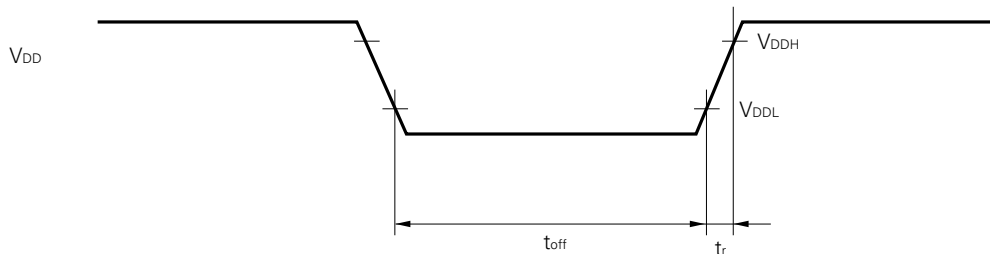

Remarks Start the power supply smoothly.

AC CHARACTERISTICS (Ta = -40 to +85 °C , VDD = 2.7 to 6.0 V)

PARAMETER	SYMBOL	TEST CONDITIONS		MIN.	TYP.	MAX.	UNIT
CPU clock cycle time (minimum instruction execution time = 1 machine cycle) *1	tcy	Operation with main system clock	VDD = 4.5 to 6.0 V	0.95		32	μs
				3.8		32	μs
		Operation with sub-system clock		114	122	125	μs
TIO input frequency	fTI	VDD = 4.5 to 6.0 V		0		0.6	MHz
				0		165	kHz
TIO input high and low-level widths	tTIH,	VDD = 4.5 to 6.0 V		0.83			μs
	tTIL			3			μs
SCK cycle time	tkcy	VDD = 4.5 to 6.0 V	Input	0.8			μs
			Output	0.95			μs
			Input	3.2			μs
			Output	3.8			μs
SCK high and low-level widths	tkH,	VDD = 4.5 to 6.0 V	Input	0.4			μs
			Output	tkcy/2-50			ns
	tkL		Input	1.6			μs
			Output	tkcy/2-150			ns
SI setup time (to SCK↑)	tSIK			100			ns
SI hold time (from SCK↑)	tKSI			400			ns
SO output delay time from SCK↓	tkSO	VDD = 4.5 to 6.0 V				300	ns
						1000	ns
Interrupt input high and low-level widths	tINTH, tINTL			INT0	*2		μs
				INT1	2tcy		μs
				INT2, 4	10		μs
RESET low-level width	trSL			10			μs

- * 1. CPU clock (ϕ) cycle time is determined by the oscillator frequency of the connected resonator, the system clock control register (SCC) and the processor clock control register (PCC). The cycle time t_{CY} characteristics for power supply voltage V_{DD} when the main system clock is in operation is shown below.
- 2. $2t_{CY}$ or $128/f_{XX}$ is set by interrupt mode register (IM0) setting.

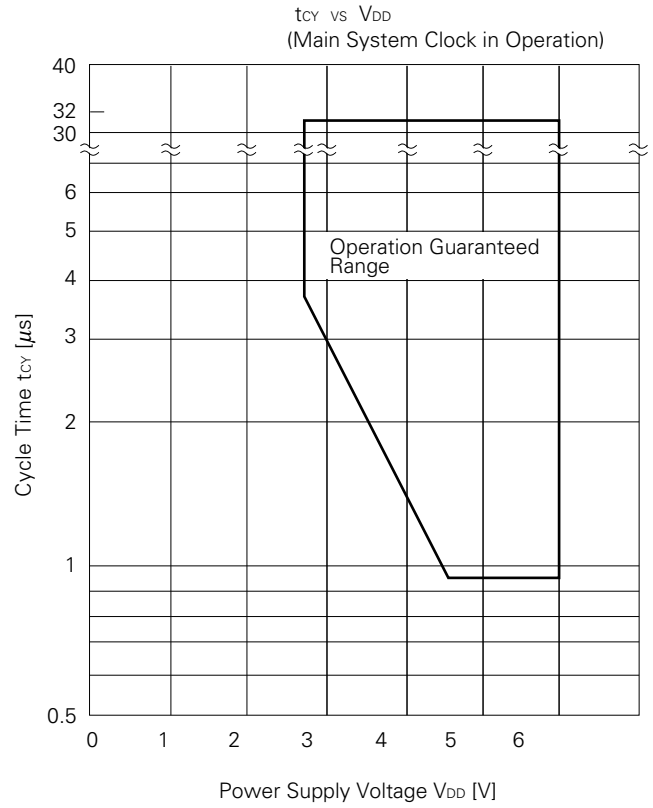

AC Timing Test Points (Except X1 and XT1 Inputs)



Clock Timing

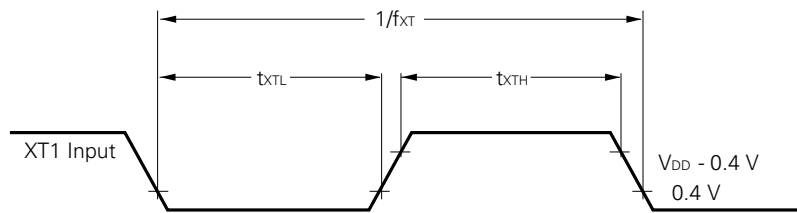
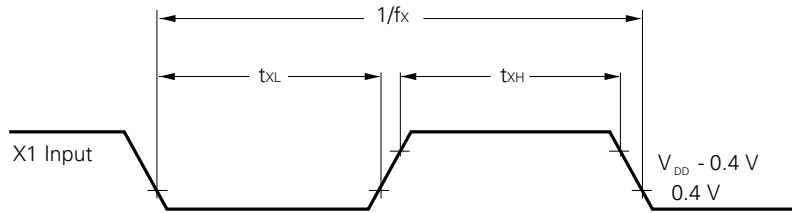

T10 Timing

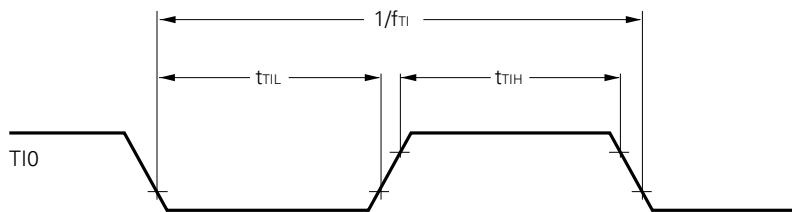

Serial Transfer Timing

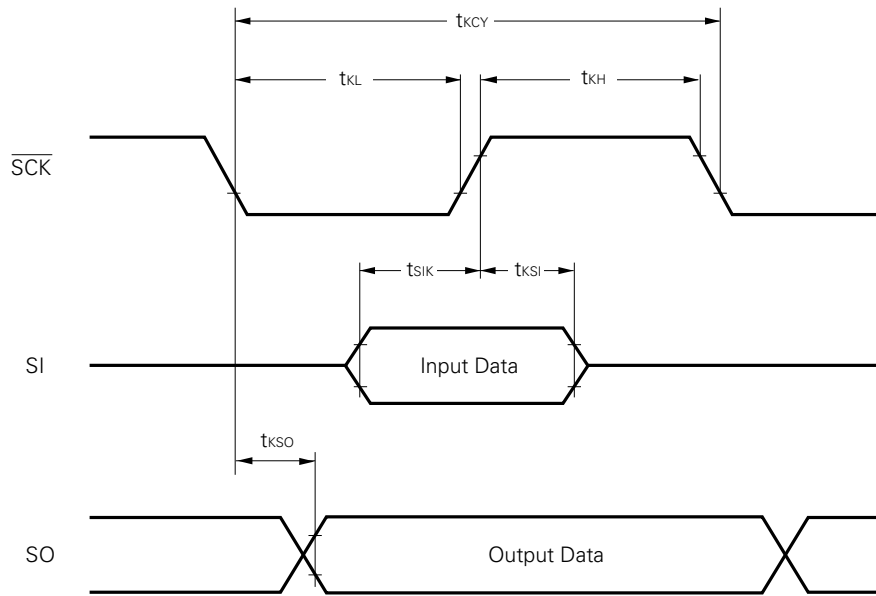

Interrupt Input Timing

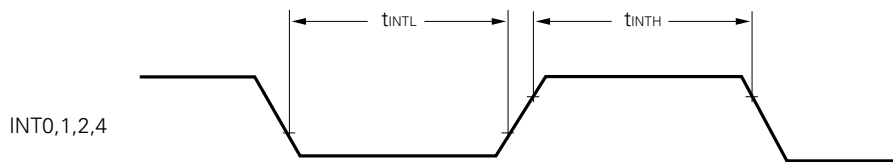

\overline{RESET} Input Timing

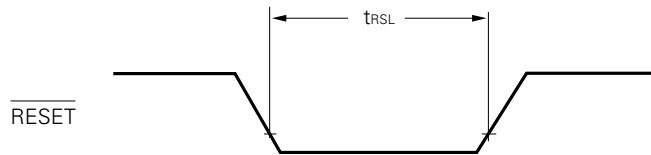

DATA MEMORY STOP MODE LOW POWER SUPPLY VOLTAGE DATA RETENTION CHARACTERISTICS (Ta = -40 to +85 °C)

PARAMETER	SYMBOL	TEST CONDITIONS	MIN.	TYP.	MAX.	UNIT
Data retention power supply voltage	V _{DDDR}		2.0		6.0	V
Data retention power supply current *1	I _{DDDR}	V _{DDDR} = 2.0V		0.1	10	μA
Release signal set time	t _{SREL}		0			μs
Oscillation stabilization wait time *2	t _{WAIT}	Release by $\overline{\text{RESET}}$		2 ¹⁷ /f _x		ms
		Release by interrupt request		*3		ms

- * 1. Current to the on-chip pull-down resistor and power-on reset circuit (mask option) is not included.
- 2. Oscillation stabilization wait time is time to stop CPU operation to prevent unstable operation upon oscillation start.
- 3. According to the setting of the basic interval timer mode register (BTM) (see below).

BTM3	BTM2	BTM1	BTM0	Wait Time (Values at f _{xx} = 4.19 MHz in parentheses)
—	0	0	0	2 ²⁰ /f _{xx} (approx. 250 ms)
—	0	1	1	2 ¹⁷ /f _{xx} (approx. 31.3 ms)
—	1	0	1	2 ¹⁵ /f _{xx} (approx. 7.82 ms)
—	1	1	1	2 ¹³ /f _{xx} (approx. 1.95 ms)

Data Retention Timing (STOP Mode Release by $\overline{\text{RESET}}$)

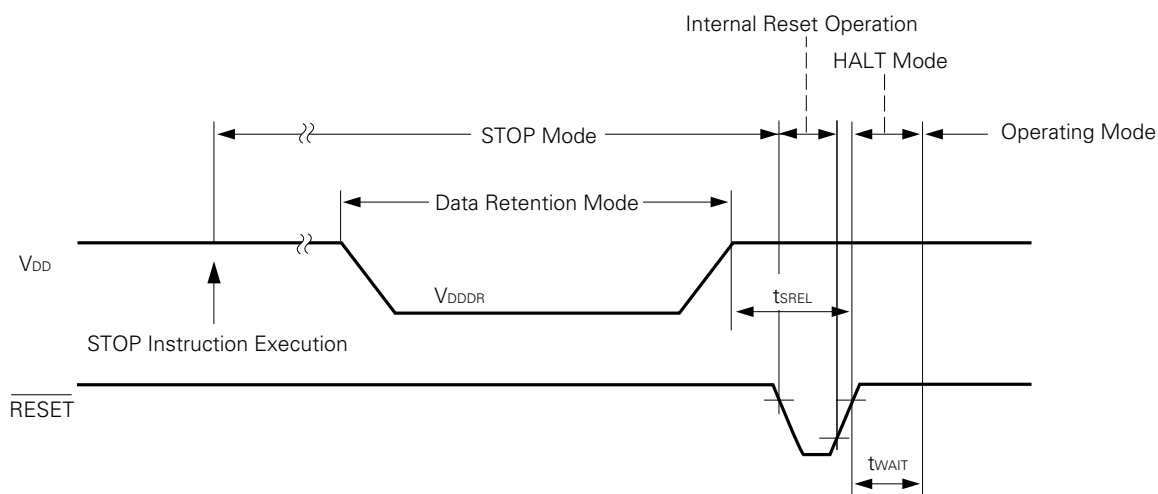

Data Retention Timing (Standby Release Signal: STOP Mode Release by Interrupt Signal)

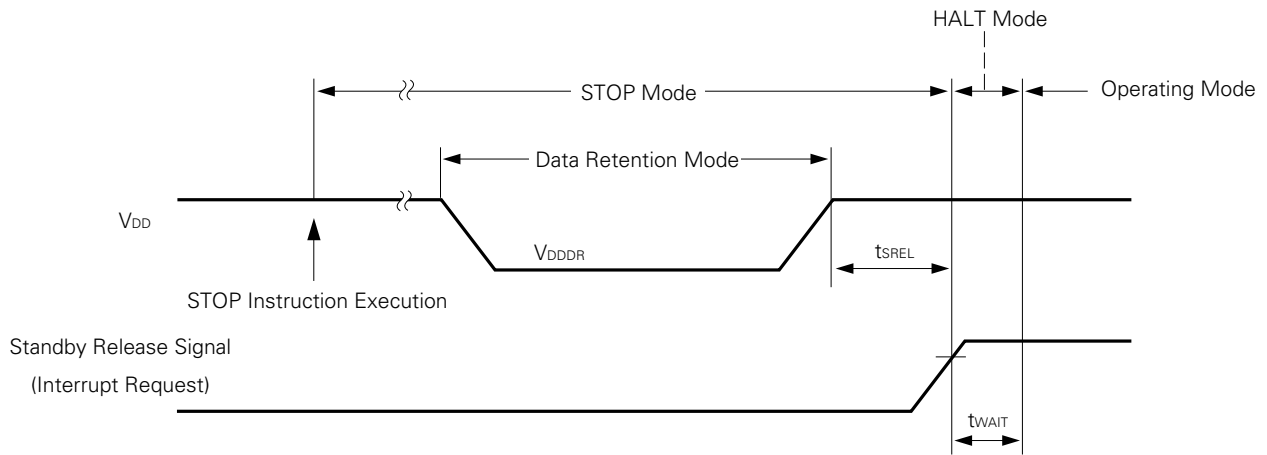

13. CHARACTERISTIC CURVES

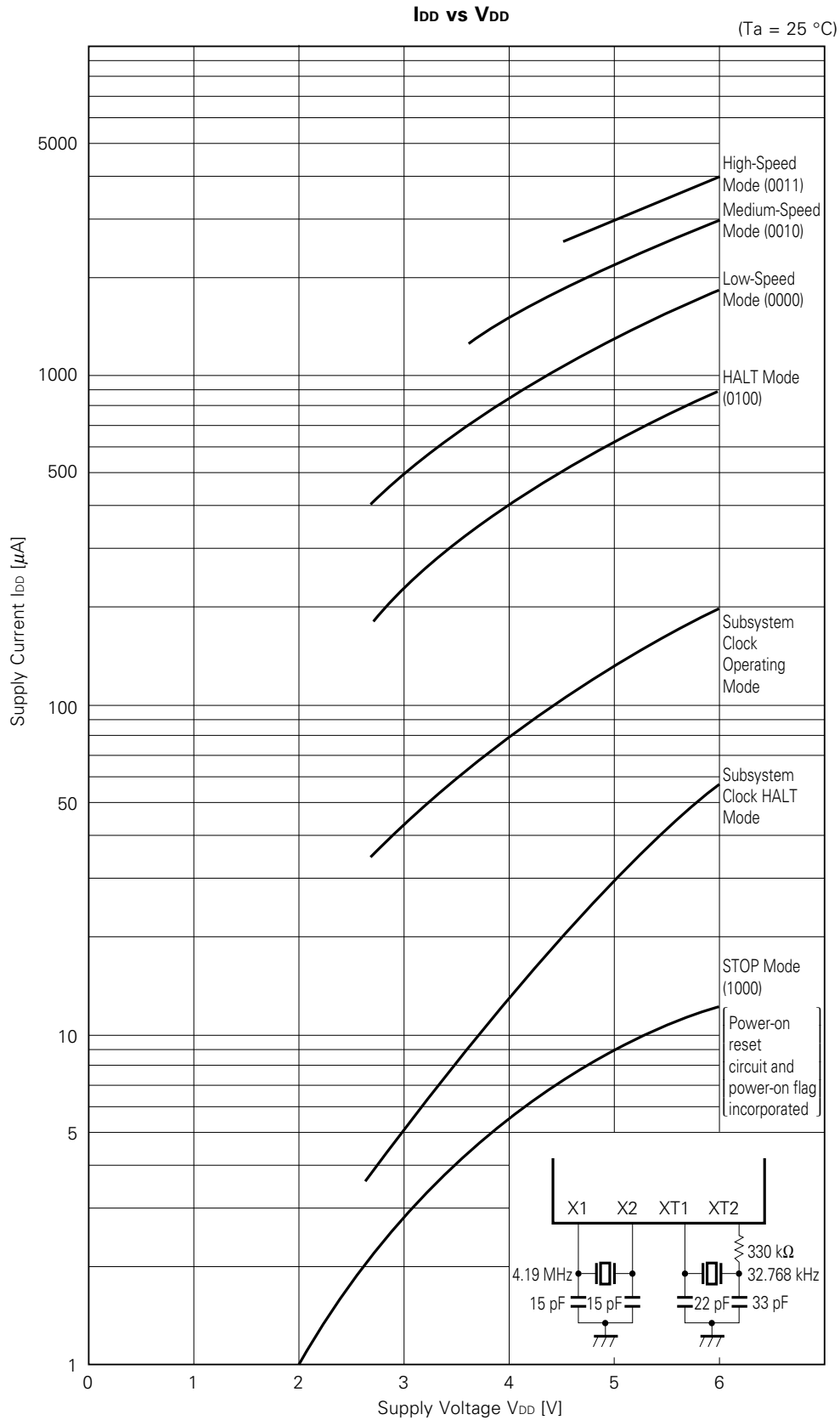

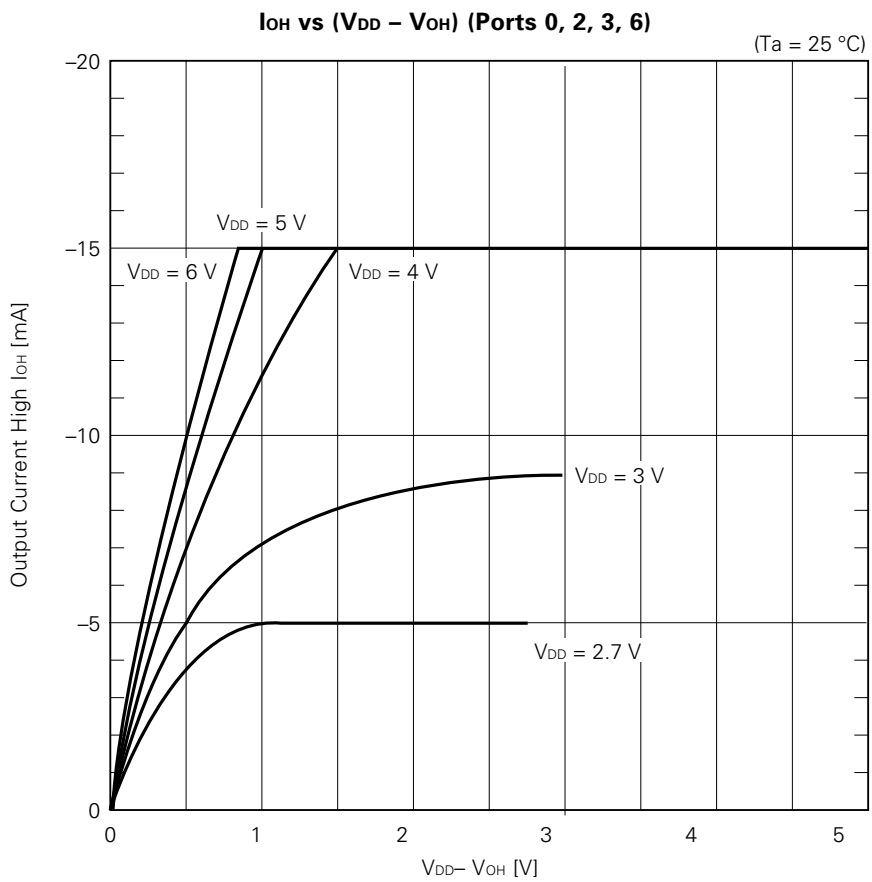
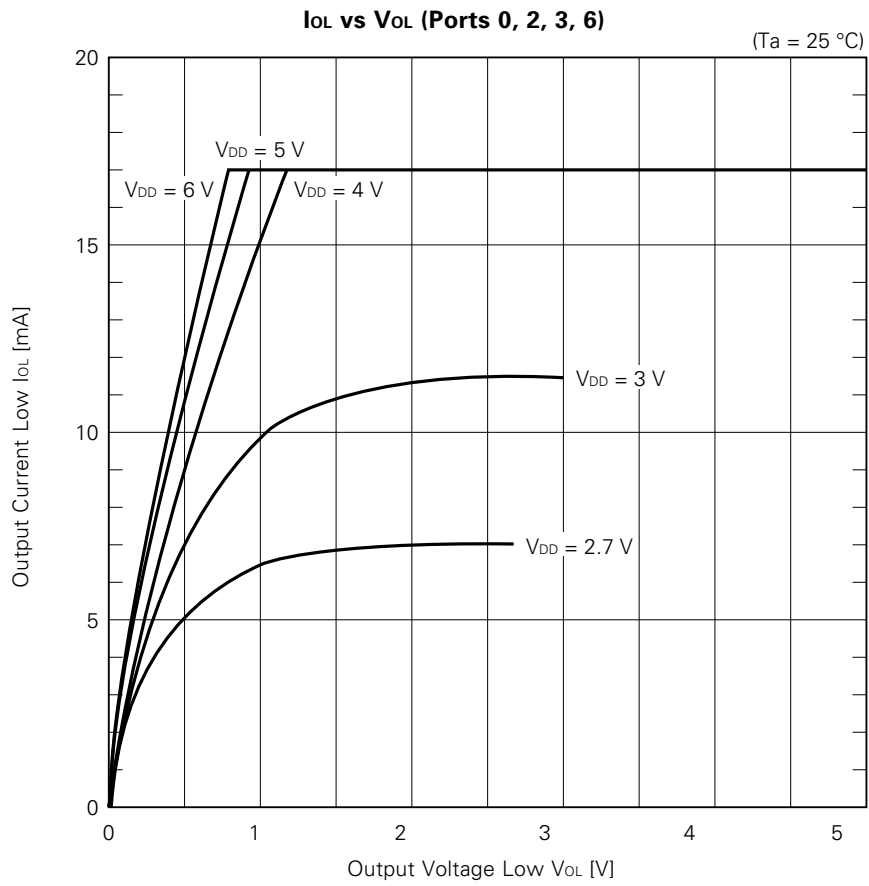

I_{OL} vs V_{OL} (Ports 4, 5)

(T_a = 25 °C)

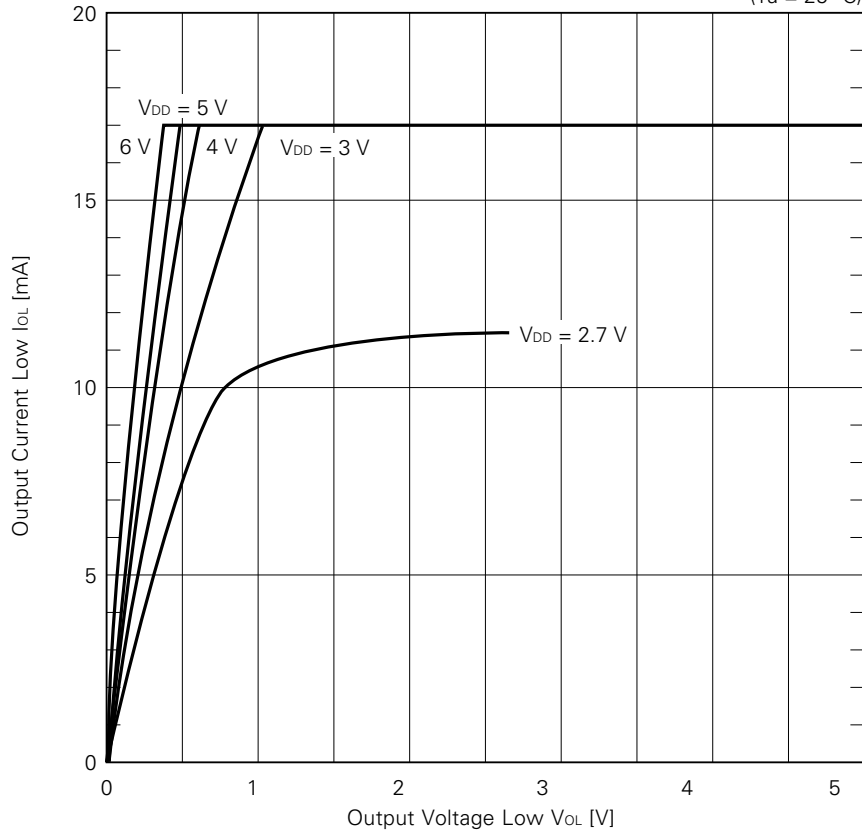

I_{OH} vs (V_{DD} - V_{OH}) (Ports 4, 5)

(T_a = 25 °C)

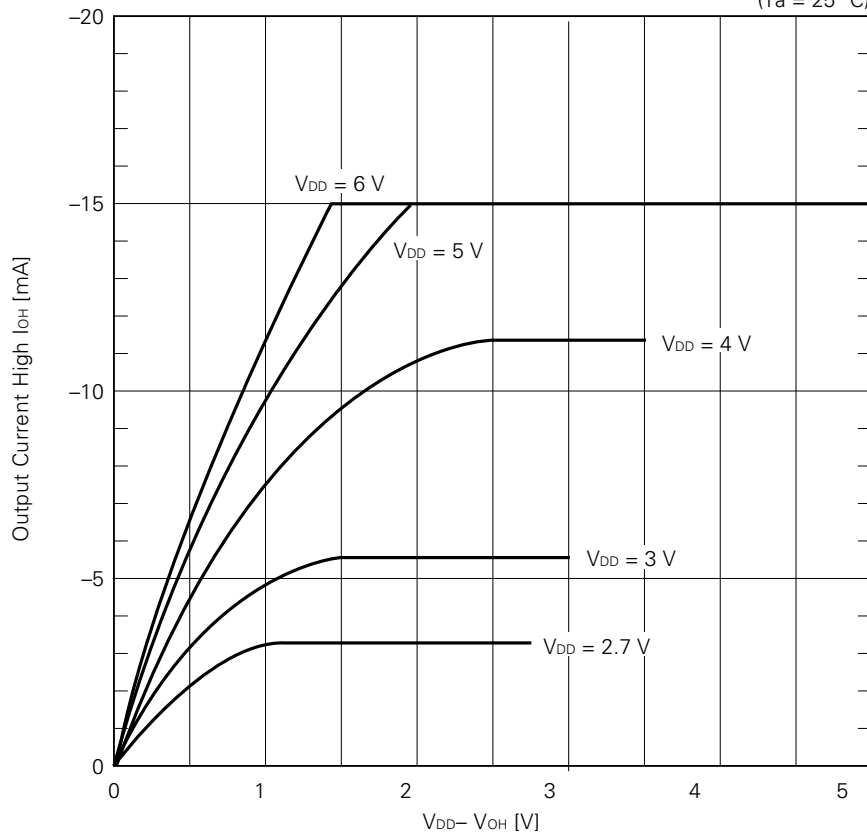

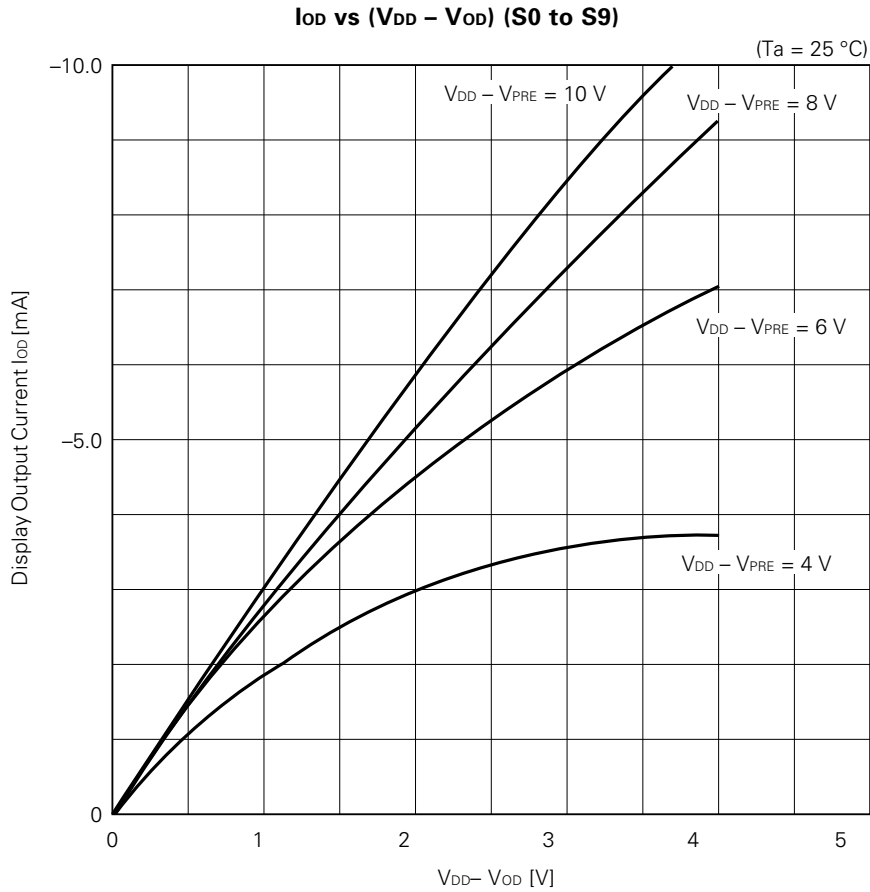
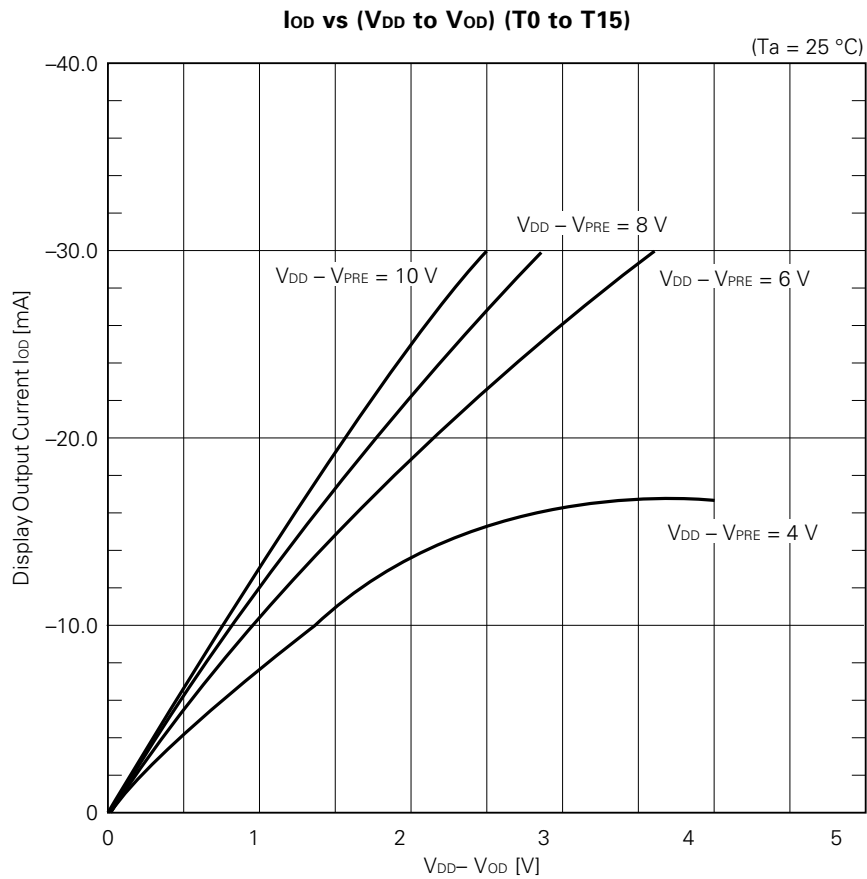

14. PACKAGE INFORMATION

64 PIN PLASTIC SHRINK DIP (750 mil)

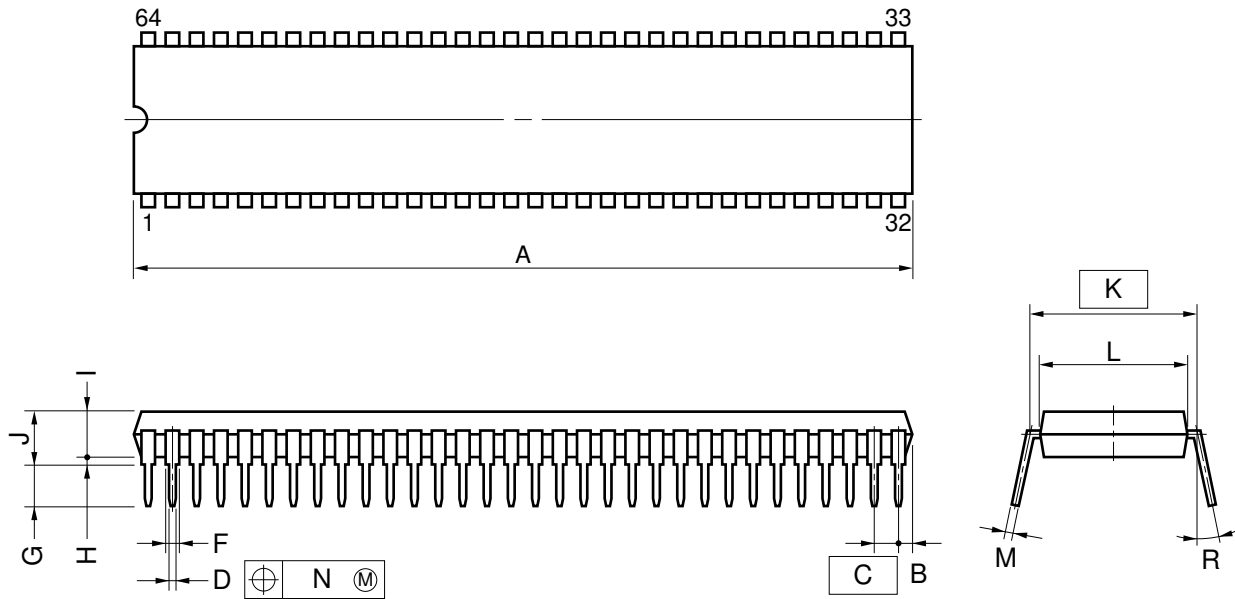

NOTE

- 1) Each lead centerline is located within 0.17 mm (0.007 inch) of its true position (T.P.) at maximum material condition.
- 2) Item "K" to center of leads when formed parallel.

ITEM	MILLIMETERS	INCHES
A	58.68 MAX.	2.311 MAX.
B	1.78 MAX.	0.070 MAX.
C	1.778 (T.P.)	0.070 (T.P.)
D	0.50±0.10	0.020 ^{+0.004} _{-0.005}
F	0.9 MIN.	0.035 MIN.
G	3.2±0.3	0.126±0.012
H	0.51 MIN.	0.020 MIN.
I	4.31 MAX.	0.170 MAX.
J	5.08 MAX.	0.200 MAX.
K	19.05 (T.P.)	0.750 (T.P.)
L	17.0	0.669
M	0.25 ^{+0.10} _{-0.05}	0.010 ^{+0.004} _{-0.003}
N	0.17	0.007
R	0~15°	0~15°

P64C-70-750A,C-1

64 PIN PLASTIC QFP (14×20)

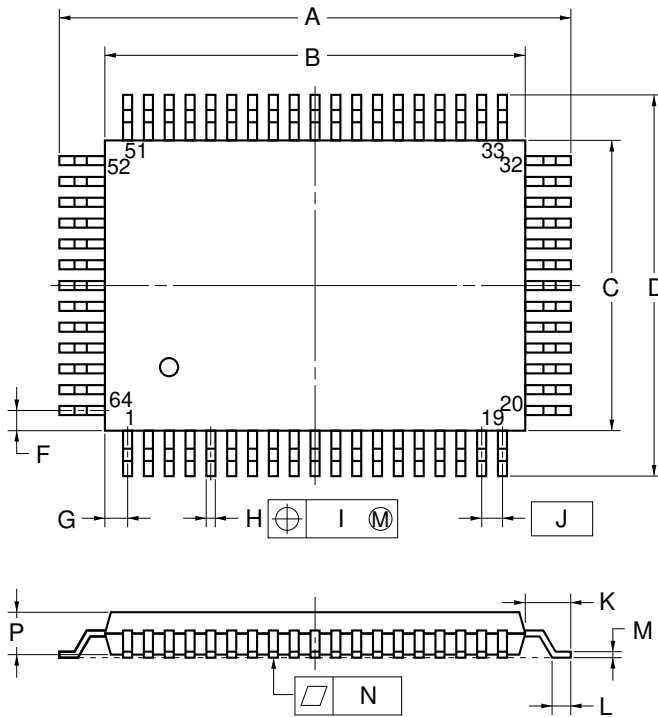

detail of lead end

NOTE

Each lead centerline is located within 0.20 mm (0.008 inch) of its true position (T.P.) at maximum material condition.

ITEM	MILLIMETERS	INCHES
A	23.6±0.4	0.929±0.016
B	20.0±0.2	0.795 ^{+0.008} _{-0.009}
C	14.0±0.2	0.551 ^{+0.009} _{-0.008}
D	17.6±0.4	0.693±0.016
F	1.0	0.039
G	1.0	0.039
H	0.40±0.10	0.016 ^{+0.004} _{-0.005}
I	0.20	0.008
J	1.0 (T.P.)	0.039 (T.P)
K	1.8±0.2	0.071 ^{+0.008} _{-0.009}
L	0.8±0.2	0.031 ^{+0.009} _{-0.008}
M	0.15 ^{+0.10} _{-0.05}	0.006 ^{+0.004} _{-0.003}
N	0.10	0.004
P	2.7	0.106
Q	0.1±0.1	0.004±0.004
R	5°±5°	5°±5°
S	3.0 MAX.	0.119 MAX.

P64GF-100-3B8,3BE,3BR-2

64-pin ceramic QFP for ES (reference) (unit : mm)

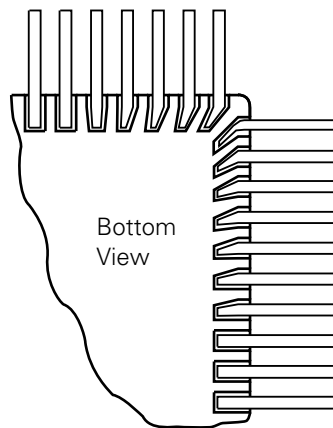
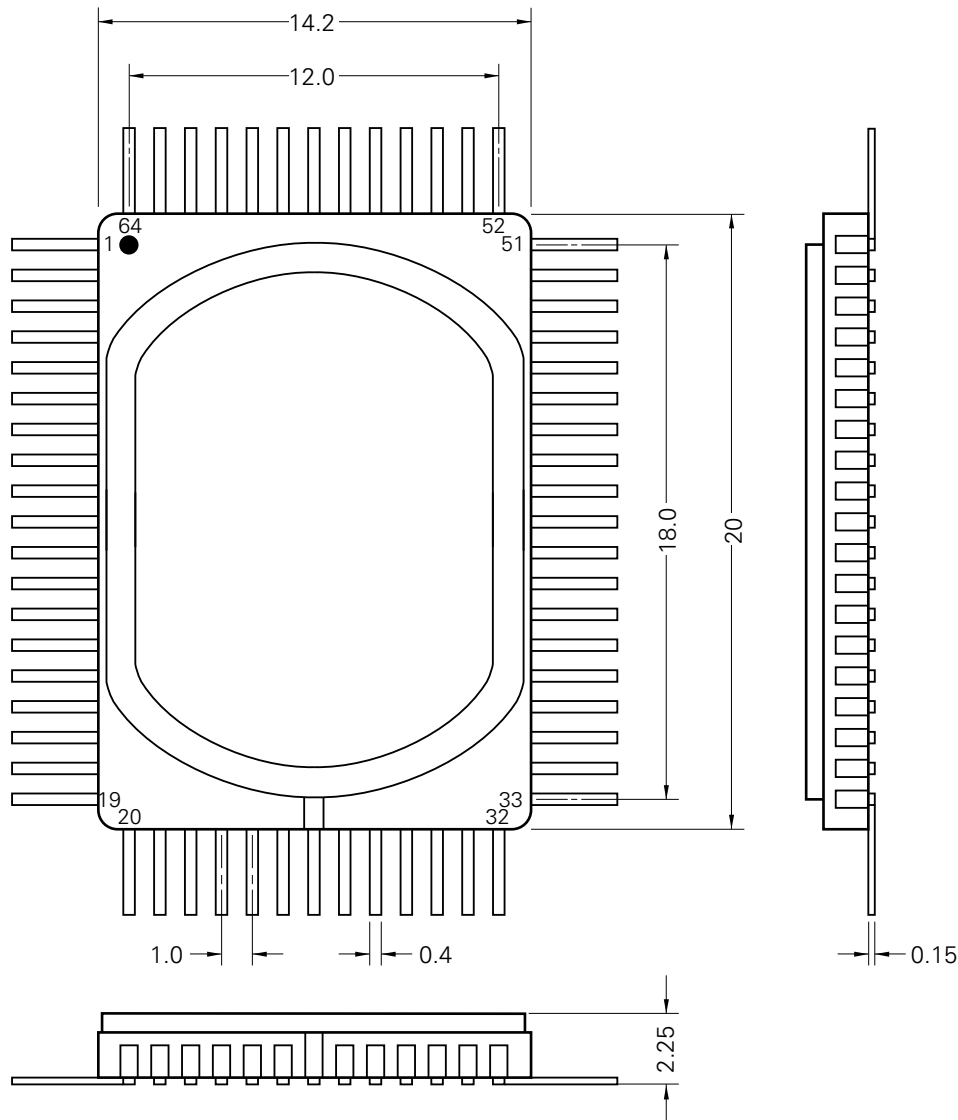

- Note**
1. Care is needed since the metal cap is connected to pin 26 and set to the positive power supply level.
 2. Care is needed since the lead of the base is formed obliquely.
 3. The lead length is not stipulated since the cutting of the lead ends is not progress-controlled.

★ 15. RECOMMENDED SOLDERING CONDITIONS

This product should be soldered and mounted under the conditions recommended below.

For details of recommended soldering conditions for the surface mounting type, refer to the document “Semiconductor Device Mount Technology” (IEI-1207).

For soldering methods and conditions other than those recommended below, contact our salesman.

Table 15-1 Surface Mounting Type Conditions

μPD75216AGF-xxx-3BE : 64-pin plastic QFP (14 × 20 mm)

Soldering Method	Soldering Conditions	Recommended Condition Symbol
Wave soldering	Solder bath temperature: 260 °C or less, Duration: 10 sec. max. Number of times: Once, Time limit: 7 days* (thereafter 10 hours prebaking required at 125 °C) Preheating temperature : 120 °C max. (package surface temperature)	WS60-107-1
Infrared reflow	Package peak temperature: 230 °C, Duration: 30 sec. max. (at 210 °C or above), Number of times: Once, Time limit: 7 days*(thereafter 10 hours prebaking required at 125 °C)	IR-30-107-1
VPS	Package peak temperature: 215 °C, Duration: 40 sec. max. (at 200 °C or above), Number of times: Once, Time limit: 7 days* (thereafter 10 hours prebaking required at 125 °C)	VP15-107-1
Pin part heating	Pin part temperature: 300 °C or below , Duration: 3 sec. max. (per device side)	—

* For the storage period after dry-pack decompression storage conditions are max. 25 °C, 65 % RH.

Note Use of more than one soldering method should be avoided (except in the case of pin part heating).

Notice

A Version of this product with improved recommended soldering condition is available. For details (improvements such as infrared reflow peak temperature extension (235 °C), number of times: twice, relaxation of time limit, etc.), contact NEC sales personnel.

Table 15-2 Insertion Type Soldering Conditions

μPD75216ACW-xxx : 64-pin plastic shrink DIP (750 mil)

Soldering Method	Soldering Conditions
Wave soldering (lead part only)	Solder bath temperature: 260 °C or below , Duration: 10 sec. max.
Pin part heating	Pin part temperature: 260 °C or below , Duration: 10 sec. max.

Note Ensure that the application of wave soldering is limited to the lead part and no solder touches the main unit directly.

APPENDIX A. LIST OF μPD75216A SERIES PRODUCT FUNCTIONS

Item		Product Name					
		μPD75206	μPD75208	μPD75212A	μPD75216A	μPD75P216A	μPD75P218*
ROM (byte)		6016 × 8	8064 × 8	12160 × 8	16256 × 8		32640 × 8
RAM (× 4 bits)		369 × 4	497 × 4	512 × 4			1024 × 4
Instruction cycle		<ul style="list-style-type: none"> • 0.95, 1.91, 15.3 μs (Main system clock : 4.19 operation) • 122 μs (Subsystem clock : 32.768 kHz operation) 					
I/O ports (FIP® dual-function pin included and FIP dedicated pin excluded)	CMOS input	33	8	Serial input, timer input, interrupt input dual function			
	CMOS input/output		20	<ul style="list-style-type: none"> • LED direct drive capability : 8 • Mask option pull-down resistor incorporation capability : 4 		<ul style="list-style-type: none"> • LED direct drive capability : 8 • No pull-down resistor 	
	CMOS output		5	<ul style="list-style-type: none"> • PWM/pulse output : 1 • LED direct drive capability : 4 • Mask option pull-down resistor incorporation capability : 4 		<ul style="list-style-type: none"> • PWM/pulse output : 1 • LED direct drive capability : 4 • No pull-down resistor 	
FIP controller/driver	High-voltage output	26	<ul style="list-style-type: none"> • 40 V MAX. • Pull-down resistor incorporation or open-drain output specifiable by mask option 			<ul style="list-style-type: none"> • 40 V MAX. • S0 to S8, T0 to T9 : pull-down resistor • S9, T10 to T15 : open-drain output 	
	No. of segments	9 to 12 segments		9 to 16 segments			
	No. of digits	9 to 16 digits					
Timer		4 channels	<ul style="list-style-type: none"> • Timer/pulse generator : 14 bit PWM output capability • Watch timer : Buzzer output capability • Timer/event counter • Basic internal timer : Watchdog timer application capability 				
Serial interface	<ul style="list-style-type: none"> • MSB start/LSB start switchable • Serial bus configuration possible 						
Vectored interrupt	External : 3 , Internal : 5						
Test input	External : 1 , Internal : 1						
System clock oscillator	<ul style="list-style-type: none"> • Main system clock oscillation ceramic/crystal oscillation circuit : 4.194304 MHz standard • Subsystem clock oscillation crystal oscillation circuit : 32.768 kHz standard 						
Power-on reset circuit	Incorporated (mask option)				None		
Low supply voltage data retention	Yes (2 V)						
16K mode/32K mode switch function	None						Incorporated
Operating temperature range	-40 to +85 °C				-10 to +70 °C		-40 to +70 °C
Operating voltage	2.7 to 6.0 V				5V ±10 %		2.7 to 6.0 V
Package	<ul style="list-style-type: none"> • 64-pin plastic shrink DIP (750 mil) • 64-pin plastic QFP (14 × 20 mm) 				<ul style="list-style-type: none"> • 64-pin plastic shrink DIP (750 mil) 		<ul style="list-style-type: none"> • 64-pin plastic shrink DIP (750 mil) • 64-pin plastic QFP(14×20mm) • 64-pin ceramic WQFN (14 × 20 mm)

- * Can be operated at 6.0 MHz. If used in 16K mode, can be used for evaluation and limited production of the μ PD75216A series.

APPENDIX B. DEVELOPMENT TOOLS

The following development tools are available for the development of systems using the μPD75216A.

Hardware	IE-75000-R*1 IE-75001-R	In-circuit emulator for the 75X series
	IE-75000-R-EM*2	Emulation board for the IE-75000-R and IE-75001-R
	EP-75216ACW-R	Emulation probe for μPD75216ACW
	EP-75216AGF-R EV-9200G-64	Emulation probe for μPD75216AGF the 64-pin conversion socket EV-9200G-64
	PG-1500	PROM programmer
	PA-75P216ACW	PROM programmer adapter for μPD75P216ACW/75P218CW in connection with PG-1500
	PA-75P218GF	PROM programmer adapter for μPD75P218GF in connection with PG-1500
	PA-75P218KB	PROM programmer adapter for μPD75P218KB in connection with PG-1500.
Software	IE control program	Host machine
	PG-1500 controller	• PC-9800 series (MS-DOS™ Ver.3.30 to Ver.5.00A*3)
	RA75X relocatable assembler	• IBM PC/AT™ (PC DOS™ Ver.3.1)

- * 1. Maintenance product
- 2. Not incorporated in the IE-75001-R
- 3. The task swap function, which is provided with Ver.5.00/5.00A, is not available with this software. ★

Remarks For development tools manufactured by a third party, see the **75X Series Selection Guide (IF-151)**.

APPENDIX C. RELATED DOCUMENTS

Device Related Documents

Document Name	Document No.
User's Manual	
Instruction Application Table	
Application Note	
75X Series Selection Guide	

Development Tools Related Documents

Document Name	Document No.	
Hardware	IE-75000-R/IE-75001-R User's Manual	
	IE-75000-R-EM User's Manual	
	EP-75216ACW-R User's Manual	
	EP-75216AGF-R User's Manual	
	PG-1500 User's Manual	
Software	RA75X Assembler Package User's Manual	Operation Volume
		Language Volume
	PG-1500 Controller User's Manual	

Other Documents

Document Name	Document No.
Package Manual	
Surface Mount Technology Manual	
Quality Grade on NEC Semiconductor Devices	
NEC Semiconductor Device Reliability & Quality Control	
Electrostatic Discharge (ESD) Test	
Semiconductor Devices Quality Guarantee Guide	
Microcomputer Related Products Guide Other Manufactures Volume	

Note The contents of the above related documents are subjected to change without notice. The latest documents should be used for design, etc.

[MEMO]

No part of this document may be copied or reproduced in any form or by any means without the prior written consent of NEC Corporation. NEC Corporation assumes no responsibility for any errors which may appear in this document.

NEC Corporation does not assume any liability for infringement of patents, copyrights or other intellectual property rights of third parties by or arising from use of a device described herein or any other liability arising from use of such device. No license, either express, implied or otherwise, is granted under any patents, copyrights or other intellectual property rights of NEC Corporation or others.

The devices listed in this document are not suitable for use in aerospace equipment, submarine cables, nuclear reactor control systems and life support systems. If customers intend to use NEC devices for above applications or they intend to use "Standard" quality grade NEC devices for applications not intended by NEC, please contact our sales people in advance.

Application examples recommended by NEC Corporation

Standard : Computer, Office equipment, Communication equipment, Test and Measurement equipment, Machine tools, Industrial robots, Audio and Visual equipment, Other consumer products, etc.

Special : Automotive and Transportation equipment, Traffic control systems, Antidisaster systems, Anticrime systems, etc.

M4 92.6

EEPROM is a trademark of NEC Corporation.

FIP is a trademark of NEC Corporation.

MS-DOS is a trademark of Microsoft Corporation.

PC DOS, PC/AT are trademarks of IBM Corporation.

This datasheet has been downloaded from:

www.DatasheetCatalog.com

Datasheets for electronic components.