

# SPECIFICATION

## 1. SCOPE

This specification is applied to the piezo-element.

## 2. SPECIFICATION

(at 25°C)

2.1 Resonant Frequency	:	3.0 ± 1.0 KHz
2.2 Resonant Resistance	:	500 Ω max
2.3 Capacitance	:	30000 pF ± 30% at 100 Hz
2.4 Input Voltage	:	30 Vp-p max
2.5 Operating Temperature	:	-20 ~ +50 °C
2.6 Storage Temperature	:	-20 ~ +60 °C
3. DIMENSION	:	as per figure

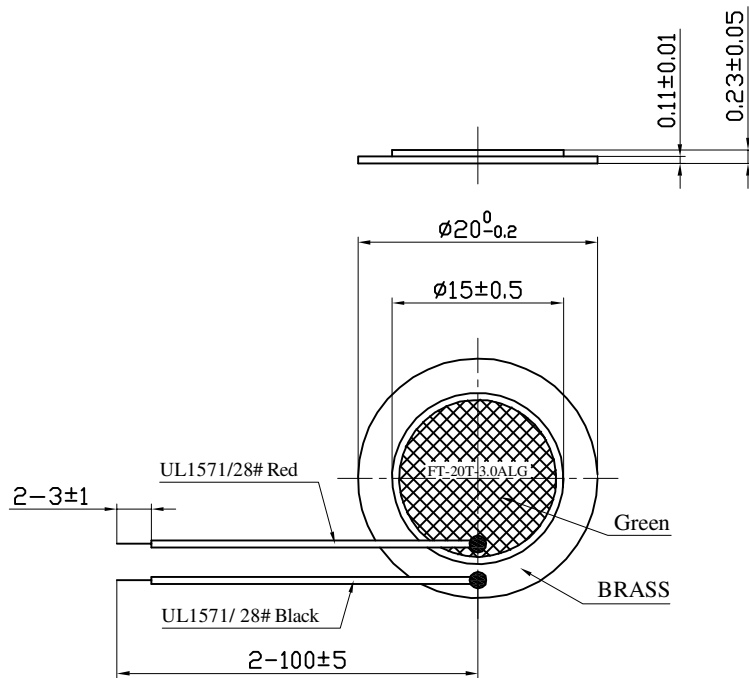

TOLERANCES UNLESS NOTED OTHERWISE .X ± .XX ± .XXX ± 90° FORMED +2° ANGLES -1°	DRAWN	WMX	KEPO MODEL NO.	CUSTOMER				
	DESIGN	WMX	FT-20T-3.0AL100-G-1922	QUARTZ-1				
	CHECKED	XJS		CUSTOMER NO.				
	APPROVED	WDY	DWG NO.		VER	1.1	SCALE	
	DATE	06.11.28	OEM1922		UNIT	mm	SHEET	
	CONTRACT NO.				KEPO CO., LTD.		TEL: (+86)574-88370330	
AGENCY APPROVAL		FAX: (+86)574-88370329						

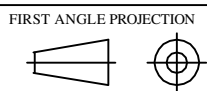

1

2

3

4