

SPECIFICATION

Customer : AUX

Applied To :

Product Name : Two mode speaker

Model Name : KP1810M1-822

Drawing No. : KFC3239

Signature of Approval

--

Signature of KEPO

Approved by	Checked by	Issued by	Date



Ningbo KePO Electronics Co.,Ltd.

*Address: No.25 Baoyuan Road Dongqian Lake Industrial Area
Dongqian Lake, Ningbo315121, China
Tel: +86(574)88371186, 88370330 Fax: +86(574)88370329
<http://www.chinaacoustic.com> E-mail: Sales@kepo.com.cn*

Specification for Two Mode Speaker	Page	2/10
Model No. : KP1810M1-822	Revision No.	1.1
	Drawing No.	KFC3239

CONTENTS

1. Scope
2. General
3. Electrical and Acoustic Characteristics.
4. Reliability Test
5. Measurement Block Diagram & Response curve
6. Structure
7. Dimensions
8. Packing
9. Revision

Specification for Two Mode Speaker		Page	3/10
Model No. :	KP1810M1-822	Revision No.	1.1
		Drawing No.	KFC3239

1. Scope

This specification is applied to the two mode dynamic speaker which is used all of the electrical acoustic product.

- compact, rich sound
- applications: mobile phone, PDA, notebook computer, etc. ..

2. General

- 2.1 Out-Diameter : 1810 mm
- 2.2 Height : 4.0 mm
- 2.3 Weight : 1.1 gr.
- 2.4 Operating Temperature range:
-20~+70℃ without loss of function
- 2.5 Store Temperature range:
-40~+85℃ without loss of function

3. Electrical and Acoustic Characteristics.

Test condition : 15 ~ 35 ℃, 25% ~ 85% RH, 860~1060 mbar

3.1 Speaker

	Items	Specification
1	Impedance	$8\ \Omega \pm 15\%$ (at 1Vrms,1.5kHz)
2	Sound Pressure Level	85dB \pm 3dB(1kHz/0.1W/0.1M)
3	Resonance Frequency	1000 Hz \pm 20%
4	Frequency Range	F _o ~ 10.0kHz
5	Input Power	Rated 0.5W / Max. 1.1W
6	Distortion	<10% Max. at 2kHz/2Vrms
7	Buzz and Rattle	Should not be audible buzzes,rattles when the 2.0V sine wave signal swept at frequency range.
8	Polarity	When supplied plus D.C. voltage to (+) terminal, the cone diaphragm must move to forward.

3.2 Receiver

	Items	Specification
1	Impedance	$8\ \Omega \pm 15\%$ (at 1Vrms,1.5kHz)
2	Sound Pressure Level	112 dB \pm 3dB(1kHz/100mV)
3	Frequency Range	300~3400Hz
4	Input Power	Rated 10mW / Max. 30mW
5	Distortion	<3% Max. at 1kHz/1Vrms
6	Buzz and Rattle	Should not be audible buzzes,rattles when the 0.28V sine wave signal swept at frequency range.

Specification for Two Mode Speaker		Page	4/10
Model No. :	KP1810M1-822	Revision No.	1.1
		Drawing No.	KFC3239

4. Reliability Test

After test(1~7item), the speaker S.P.L . difference shall be within $\pm 3\text{dB}$, and the appearance not exist any change to be harmful to normal operation(e.g. cracks,rusts,damages and especially distortion).

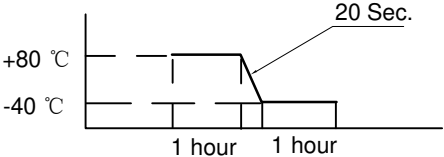
	Item	Specification
1	High Temperature Test	After being placed in a chamber with $+85\pm 3\text{ }^\circ\text{C}$ for 96 hours and then being placed in natural condition for 1 hour, speaker shall be measured.
2	Low Temperature Test	After being placed in a chamber with $-40\pm 3\text{ }^\circ\text{C}$ for 96 hours and then being placed in natural condition for 1 hour, speaker shall be measured.
3	Humidity Test	After being placed in a chamber with 85 to 90%R.H. at $+40\pm 2\text{ }^\circ\text{C}$ for 96 hours and then being placed in natural condition for 1 hour, speaker shall be measured.
4	Thermal Shock Test	<p>After being placed in a chamber at $+80\text{ }^\circ\text{C}$ for 1 hour, then speaker shall be placed in a chamber at $-40\text{ }^\circ\text{C}$ for 1 hour(1 cycle is the below diagram).</p> <p>After 6 above cycles, speaker shall be measured after being placed in natural condition for 1 hour.</p> 
5	Vibration Test	After being applied vibration of amplitude of 1.5mm with 10 to 55Hz band of vibration frequency to each of 3 perpendicular directions for 1 hour, then placed in natural condition for 1 hour, speaker shall be measured.
6	Drop Test	The speaker when mounted in the jig which weight 85g~100g, shall with stand 15 times random drops from a height of 1.5 meter to a concrete floor faced with 5mm thick hard wood board.and be nothing mechanical damage.
7	Load test	The speaker after being applied loading white noise with input power 0.5W(2.0Vrms.) for 96 hours, then placed in natural condition for 1 hour, speaker shall be measured.
		The receiver after being applied loading white noise with input power 10mW(0.28Vrms.) for 96 hours, then placed in natural condition for 1 hour, speaker shall be measured.
8	Insulation test	When they are measured with DC 100V the insulation resistance between v.c. terminal and frame must be more than 1 M Ω

Specification for Two Mode Speaker		Page	5/10
Model No. : KP1810M1-822		Revision No.	1.1
		Drawing No.	KFC3239

5. Measurement Block Diagram & Response curve

5.1 Speaker

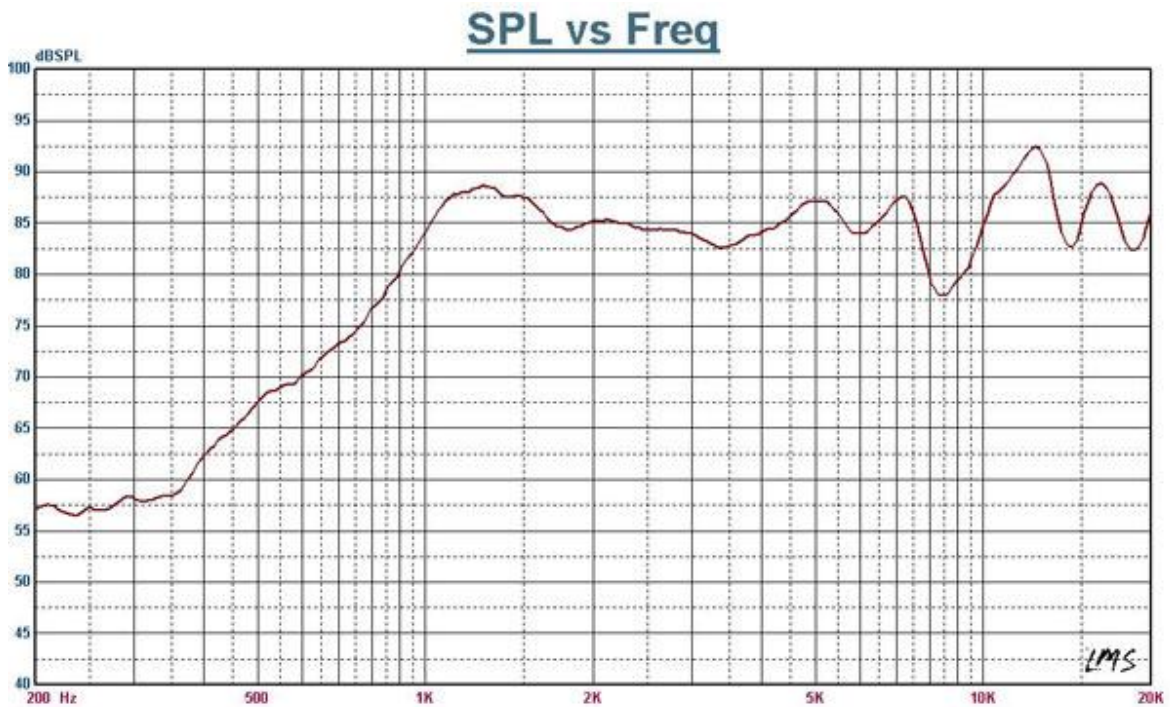
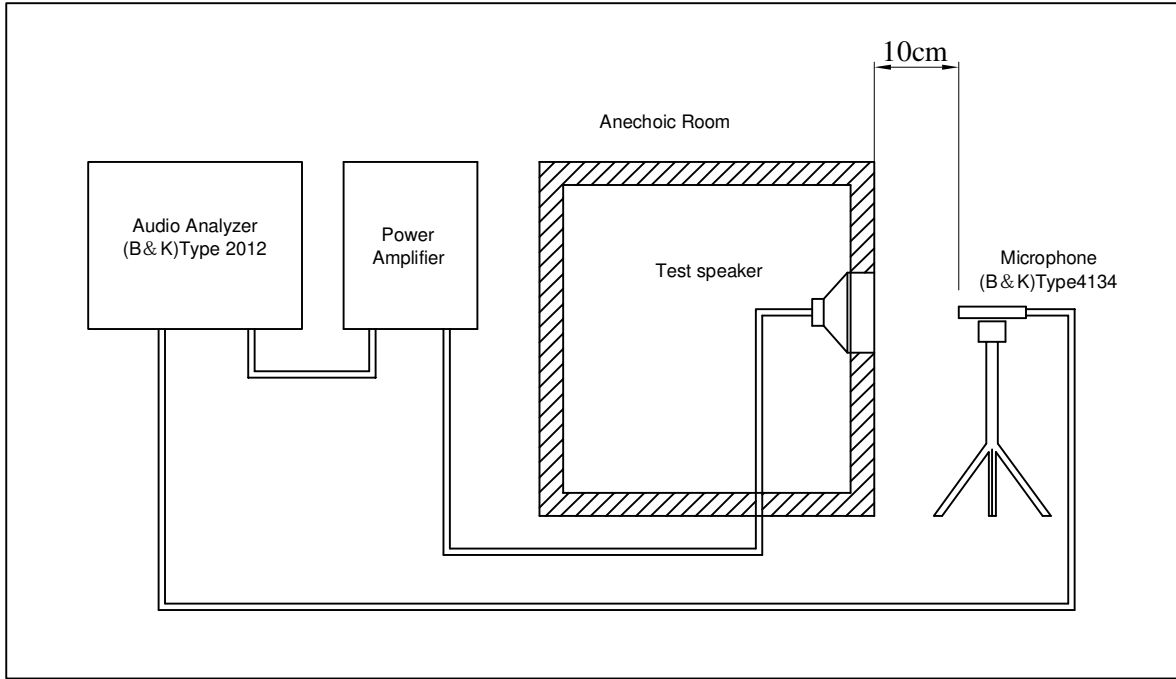

Specification for Two Mode Speaker		Page	6/10
		Revision No.	1.1
Model No. :	KP1810M1-822	Drawing No.	KFC3239

5.2 Receiver

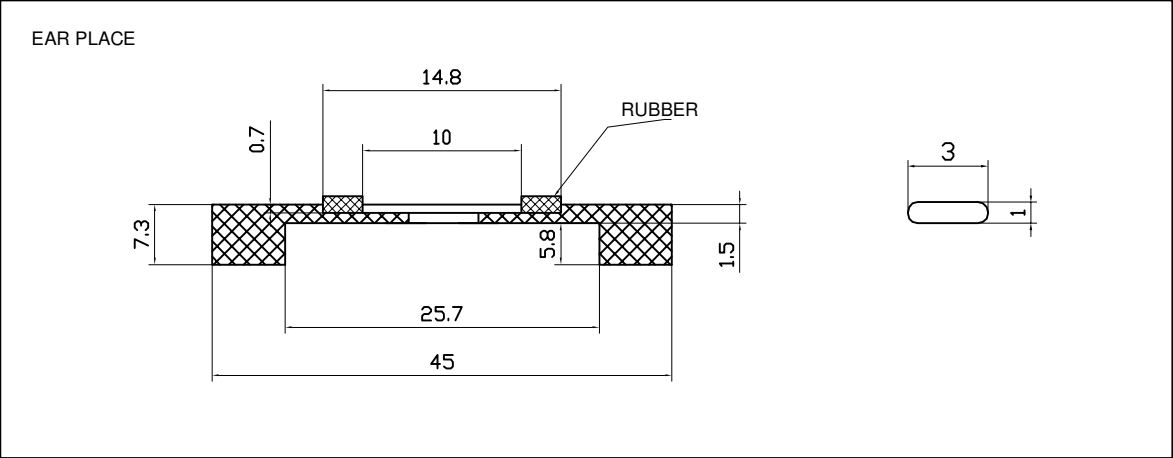
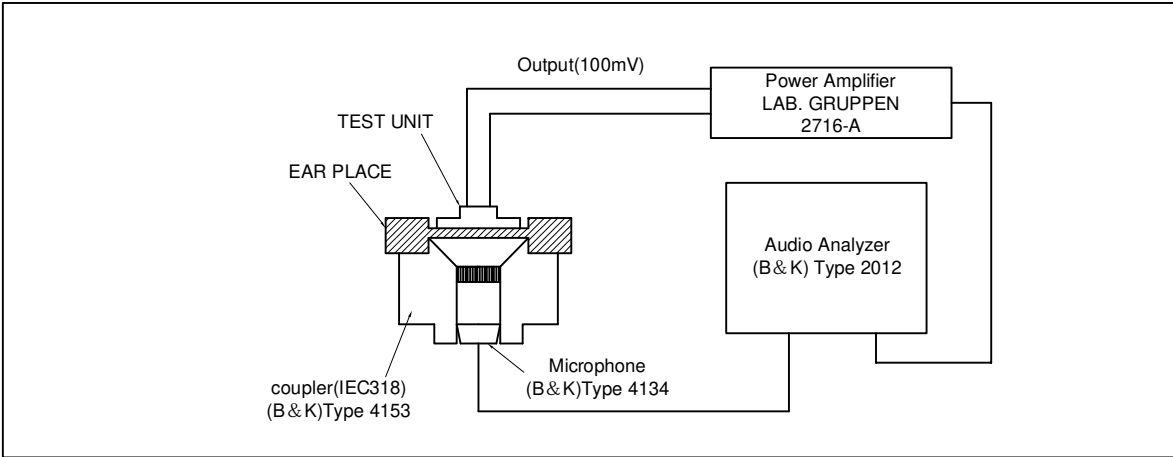

SPL vs Freq

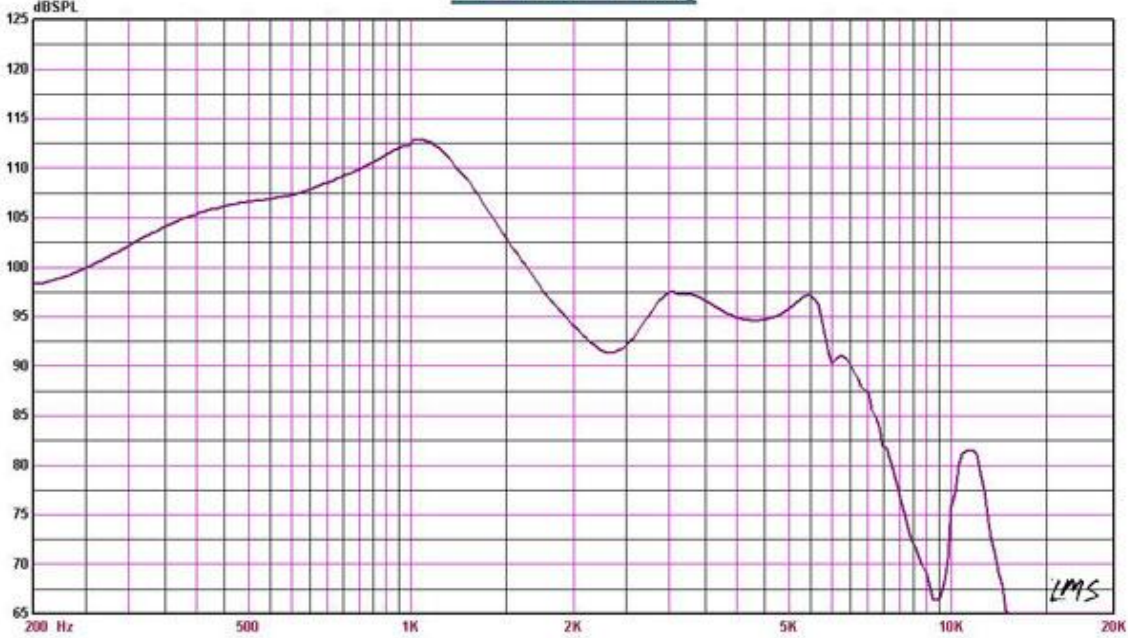

Specification for Two Mode Speaker		Page	7/10
Model No. : KP1810M1-822		Revision No.	1.1
		Drawing No.	KFC3239

6. Structure

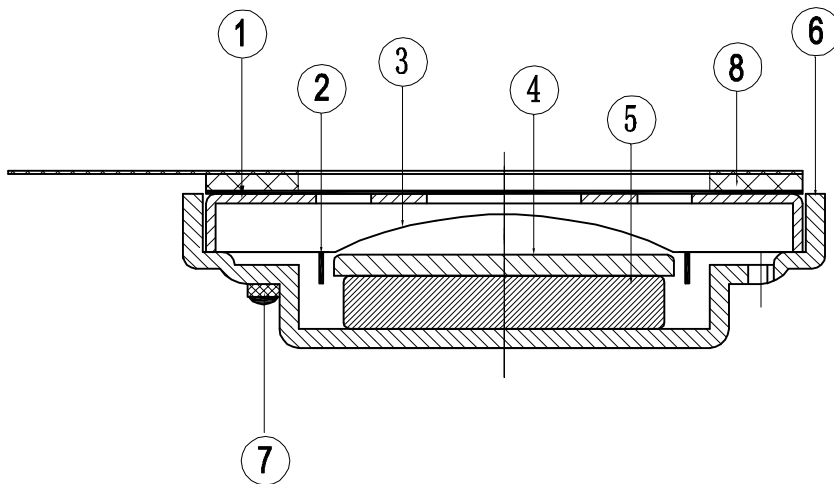

8	Gasket	1	unwoven fabric	800+2B+800+PSR0.3+800
7	Terminal	1	Epoxy PCB	
6	Frame	1	SPC	
5	Magnet	1	Nd-Fe-B	
4	Plate	1	SPC	
3	Diaphragm	1	PEI	
2	Coil	1	Copper	
1	Cap	1	SUS304	
No.	Part Name	Q'TY	Material	Remarks

Specification for Two Mode Speaker		Page	8/10
		Revision No.	1.1
Model No. :	KP1810M1-822	Drawing No.	KFC3239

7. Dimensions

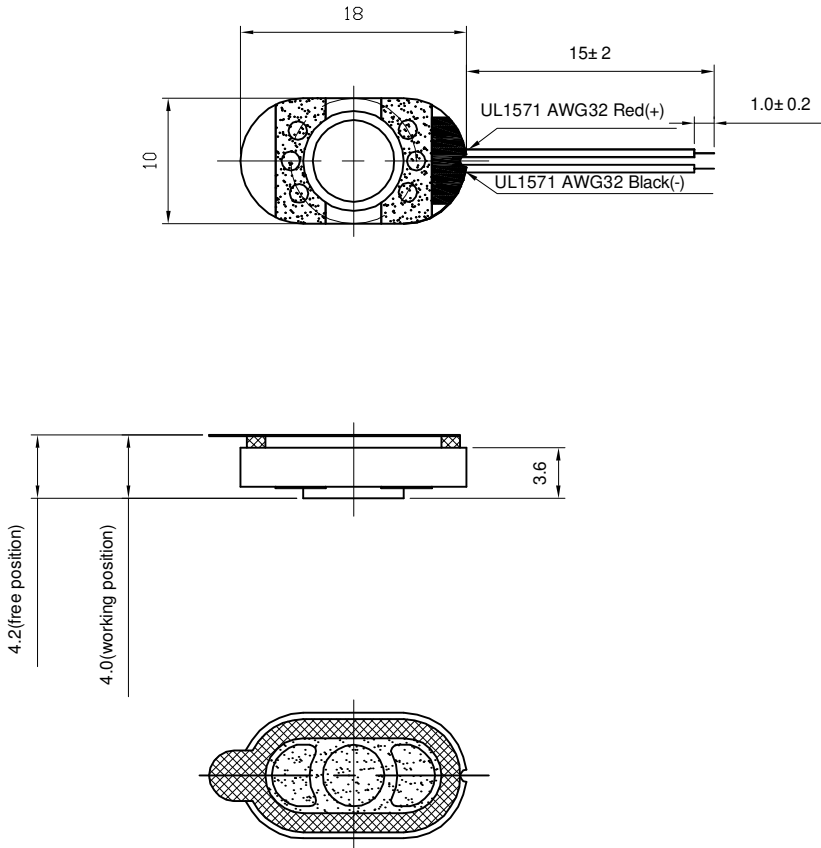

FIRST ANGLE PROJECTION

UNIT : mm
Tolerance : ± 0.2

Specification for Two Mode Speaker		Page	9/10
Model No. : KP1810M1-822		Revision No.	1.1
		Drawing No.	KFC3239

8. Packing

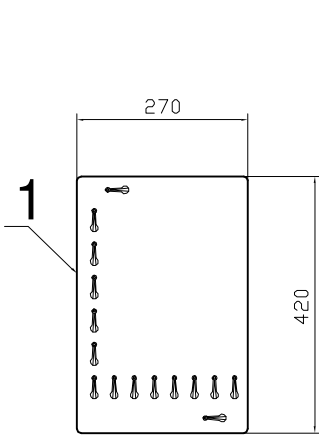

100Pcs

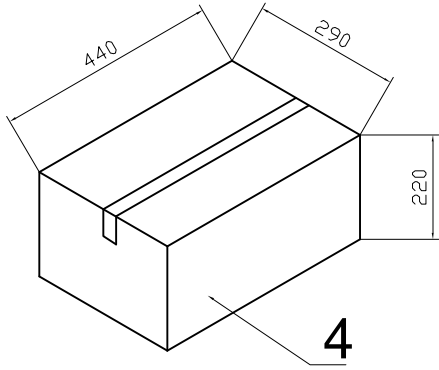
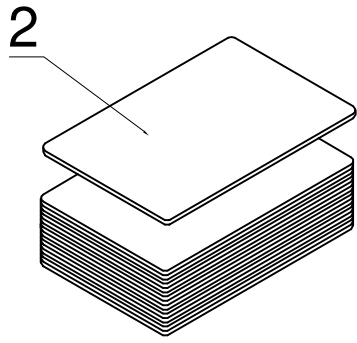
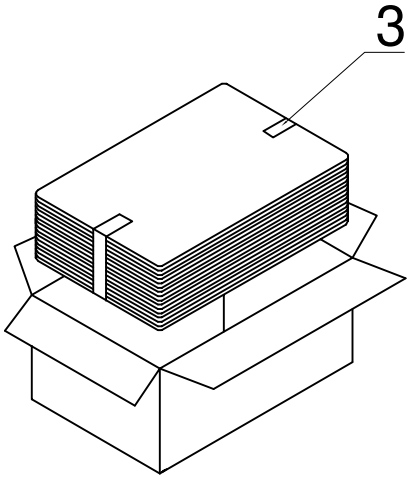

QTY: 2000Pcs
440 x290 x220

