

SPECIFICATION

受 控

Customer : QUARTZ-1

Applied To :

Product Name : Horn Speaker

Model Name : S-210R-8-5669

Drawing No. : KFC5669

Signature of Approval

| |
|--|
| |
|--|

Signature of KEPO

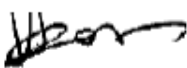
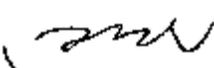
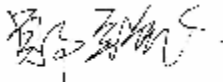
| Approved by | Checked by | Issued by | Date |
|---|---|--|------------|
|  |  |  | 2010-03-03 |

宁波凯普电子有限公司

Ningbo Kepo Electronics Co.,Ltd.



宁波东钱湖镇东钱湖工业区宝源路 25 号

TEL:+86-574-88370330 FAX:+86-574-88370329

No.25 Baoyuan road Dongqian Lake, Industry Area, Dongqian town, Ningbo City,
China(Post Code:315121)

Sales@chinaacoustic.com

www.chinaacoustic.com

| | | |
|--------------------------------|--------------|---------|
| Specification for Horn Speaker | Page | 2/8 |
| Model No. : S-210R-8-5669 | Revision No. | 1.0 |
| | Drawing No. | KFC5669 |

CONTENTS

1. Scope
范围
2. General
概要
3. Electrical and Acoustic Characteristics.
电声参数
4. Reliability Test
可靠性试验
5. Measurement Block Diagram & Response curve
测试图与曲线图
6. Structure
结构
7. Dimensions
尺寸
8. Revision
履历表

| | | | |
|--------------------------------|---------------|--------------|---------|
| Specification for Horn Speaker | | Page | 3/8 |
| | | Revision No. | 1.0 |
| Model No. : | S-210R-8-5669 | Drawing No. | KFC5669 |

1. Scope

This product specification is applied to the Siren used for sounder in alarm systems. Please contact us when using this product for any other applications than described in the above.

本规格书适用于报警器，通常它用在系统中做报警或提示，如果将该产品用于其它领域，请与我们联系。

2. General

- 2.1 Out-Diameter : **98 mm**
 外径: **98 mm**
- 2.2 Height : **169 mm**
 高度: **169 mm**
- 2.3 length : **98mm**
 长度: **98 mm**
- 2.4 Weight : **680± 10 g**
 重量: **680±10克**
- 2.5 Operating Temperature range:
-20~+60℃ without loss of function
 工作温度: **-20~+60℃**
- 2.6 Store Temperature range:
-20~+70℃ without loss of function
 储藏温度: **-20~+70℃**

3. Electrical and Acoustic Characteristics.

Test condition : 15 ~ 35 °C, 25% ~ 85% RH, 860~1060 mbar

测试条件: 15~35 °C, 25%~85%RH , 860~1060mbar

| | Items 项目 | Specification 规格 |
|----|----------------------------------|-----------------------------------|
| 1 | Case Material/Color 壳体材质/颜色 | ABS/White |
| 2 | Voice Coil dimension 音圈尺寸 | Ø 33.5mm(Dia.) |
| 3 | Power Rating RMS 额定功率 | 25W |
| 4 | Power Rating Peak 峰值功率 | 30W |
| 5 | Magnet size 磁体尺寸 | Ø80*40*12 mm(Dia.* dia.*H) |
| 6 | Min.Sound Pressure Level 额定声压 | 104± 3dB(1 meter/1 W) |
| 7 | Resonant Frequency 谐振频率 | 2.0KHz± 15% |
| 8 | Rated Frequency Range 额定频率范围 | 500~6500HZ |
| 9 | Voice Coil Impedance 音圈阻抗 | 8 Ohm± 15% |
| 10 | Max.Rated Current 额定电流 | |

| | | | |
|--------------------------------|--|--------------|---------|
| Specification for Horn Speaker | | Page | 4/8 |
| Model No. : S-210R-8-5669 | | Revision No. | 1.0 |
| | | Drawing No. | KFC5669 |

4. Reliability Test

After test(1~6item), the Electronic Siren S.P.L . difference shall be within $\pm 10\text{dB}$, and the appearance not exist any change to be harmful to normal operation(e.g.cracks,rusts,damages and especially distortion).

在1-6项试验后，报警器的声压变化值在 $\pm 10\text{dB}$ 之内，外观无变化（例如：开裂、生锈、损伤、变形等现象）。

| | Item | Specification |
|---|-------------------------------|--|
| 1 | High Temperature Test 高温试验 | <p>After being woked in a chamber with $+60\pm 2\text{ }^{\circ}\text{C}$ for 2h and then being placed in natural condition for 2h, sounder shall be measured.</p> <p>将产品置于 $+60\pm 2\text{ }^{\circ}\text{C}$ 试验箱中，先工作 2小时，然后在正常大气压条件下恢复2小时后，进行测量</p> |
| 2 | Low Temperature Test 低温试验 | <p>First being worked in a chamber with $-20\pm 2\text{ }^{\circ}\text{C}$ for 2h and then being placed in a chamber with $-20\pm 2\text{ }^{\circ}\text{C}$ for 16h, finally being placed in natural condtion for 2h, sounder shall be measured.</p> <p>将产品置于 $-20\pm 2\text{ }^{\circ}\text{C}$ 试验箱中，先工作 2小时，再放置16小时，然后在正常大气压条件下恢复2小时后，进行测量</p> |
| 3 | Humidity Test 潮湿试验 | <p>After being placed in a chamber with 90 to 95%R.H. at $+40\pm 2\text{ }^{\circ}\text{C}$ for 2 h and then being placed in natural condition for 2h , sounder shall be measured.</p> <p>将产品置于湿度为 90-95%R.H，温度为 $40\pm 2\text{ }^{\circ}\text{C}$ 试验箱中 2小时，然后在正常大气压条件下恢复2小时后，进行测量</p> |
| 4 | Shock 耐冲击性 | <p>Under acceleration of peak $100\text{m/s}^2(10\text{g})$ & half sine wave pulse (pulse time is 16ms)condition.run into product 1000 times continuously.</p> <p>峰值加速度 $100\text{m/S}^2(10\text{g})$,脉冲持续时间为16ms的半正弦波脉冲对试样连续碰撞1000次，测试报警器.</p> |
| 5 | Drop Test 跌落试验 | <p>Horn packed in the carton are dropped in six direction from the height of 50cm to the concrete floor.</p> <p>跌落高度50cm,6个不同方向整箱跌落到水泥地，试验后进行测量.</p> |
| 6 | Vibration Resistance 振动试验 | <p>Horn shall be measured after being applied vibration of amplitude of 1.5mm with 10to 30Hz band of vibration frequency to each of 3 perpendicular directions for 2 hour.</p> <p>振幅为1.5mm，频率为10-30Hz,三个不同轴方向各振动2小时，试验后进行测量.</p> |

| | | |
|--------------------------------|--------------|---------|
| Specification for Horn Speaker | Page | 5/8 |
| | Revision No. | 1.0 |
| Model No. : S-210R-8-5669 | Drawing No. | KFC5669 |

5. Measurement Block Diagram & Response curve

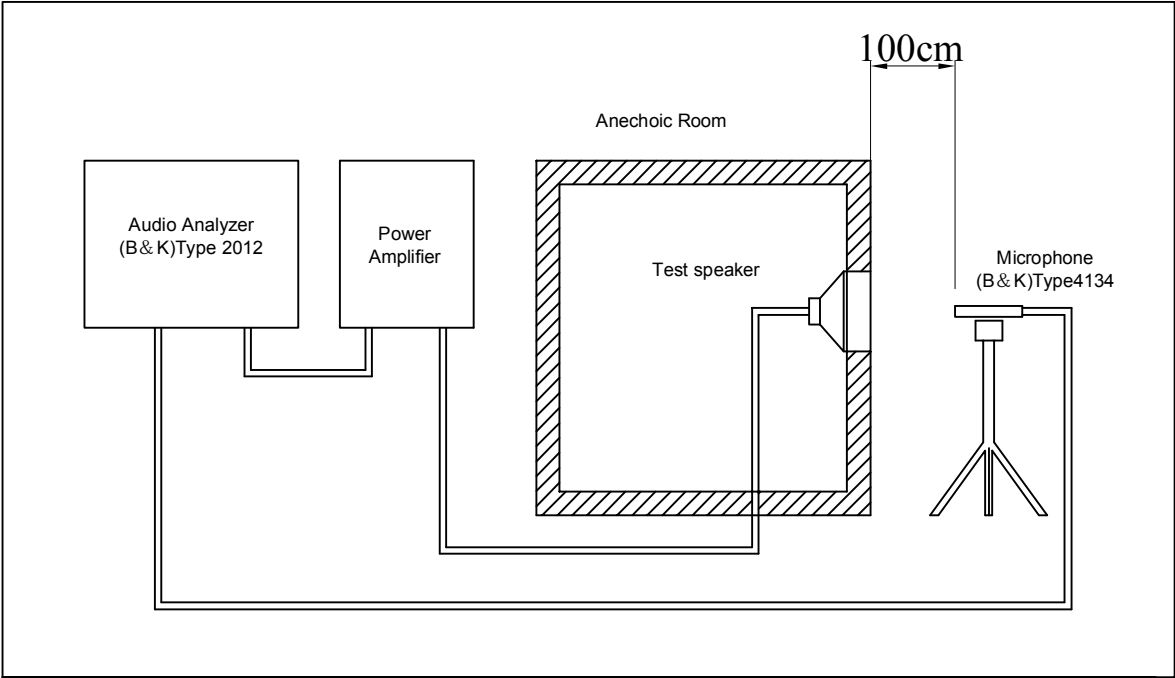

| | | |
|--------------------------------|--------------|---------|
| Specification for Horn Speaker | Page | 6/8 |
| | Revision No. | 1.0 |
| Model No. : S-210R-8-5669 | Drawing No. | KFC5669 |

6. Structure



| | | | | |
|-----|-----------------------------------|------|-----------------|-----------|
| 4 | | | | |
| 3 | | | | |
| 2 | | | | |
| 1 | Housing material/color 壳体材质/颜色 | 1 | ABS/White/Black | |
| No. | Part Name 型号 | Q'TY | Material 材质 | SGS 编号 |

| | | | |
|--------------------------------|---------------|--------------|---------|
| Specification for Horn Speaker | | Page | 7/8 |
| Model No. : | S-210R-8-5669 | Revision No. | 1.0 |
| | | Drawing No. | KFC5669 |

7. Dimensions

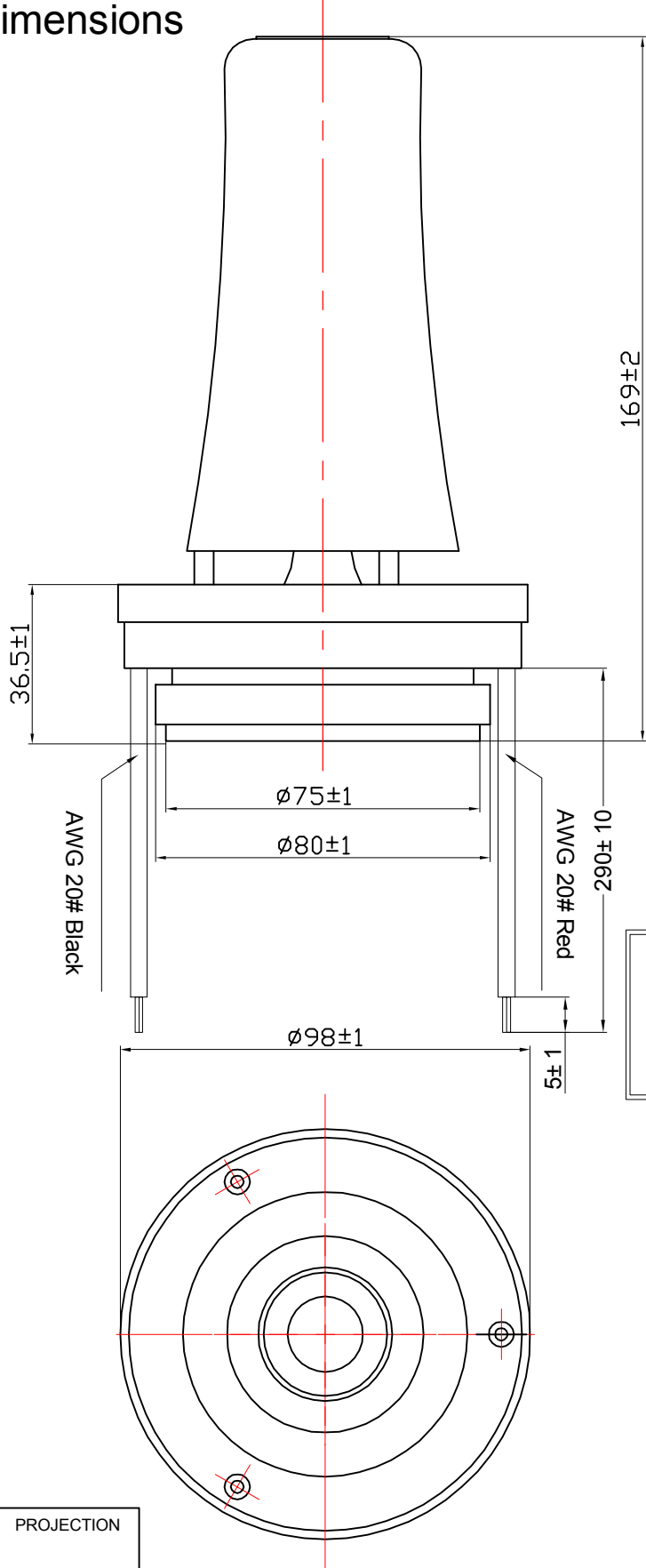

标贴内容

| |
|---|
| <p>KEPO S-210R-8-5669 8 Ω 25W</p> |
|---|

FIRST ANGLE PROJECTION

UNIT : mm
Tolerance : ±0.5

