

# Mini Push Switch

**Q-2073**

TYPE: **P2-0S**

## SPECIFICATIONS

Rating	DC 30V, 100mA
Contacts Resistance	100MΩ Max
Insulation Resistance	100MΩ Min
Minimum Load	DC 100V
Dielectric Strengths	AC 125V / 1 minute
Life Test	10 000 Cycles Min
Operating temperature range	-25°C to +65°C
Operating Force:	150 ± 50gf

Outline Drawing

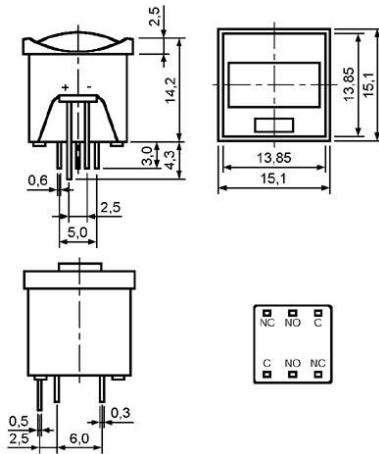

Mounting

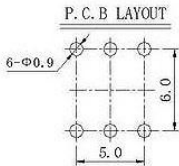

Circuitry

